

Salton Community Services District
REGULAR MEETING *Agenda*
May 20, 2026
Closed Session 1:00 p.m.
Open Session 2:00 p.m.
1209 Van Buren Ave.
Salton City, CA 92275
www.saltoncsd.ca.gov

BOARD OF DIRECTORS:

Michael Friese, President
Oscar Ramirez, Vice President
Manuel Ramos, Director
Lidia A. Sierra, Director
David Reagle, Director

STAFF:

Emmanuel Ramos, General Manager
Christina Sutton, Finance Officer
Thania Garcia, Board Secretary
Jazmine Madrigal, Admin Assistant
Omar Ruiz, Field Foreman
Pascual Muniz, Park Supervisor
Robert Patterson, Legal Counsel

1. CALL TO ORDER: 1:00 p.m.

2. ROLL CALL:

3. PUBLIC COMMENTS:

Pursuant to California Government Code Section 54954.3, the public has the right to address the board regarding any closed session items listed on the **closed session agenda** prior to the board adjourning into closed session. Anyone who wishes to address the Board, please come to the microphone. Public comments are limited to (3) minutes for each person. Comments are not to be directed towards an individual or individuals but to the Board on a specific issue.

4. CLOSED SESSION ITEMS:

A. CONFERENCE WITH LEGAL COUNSEL—ANTICIPATED LITIGATION
Initiation of litigation pursuant to paragraph (4) of subdivision (d) of Section 54956.9:
(Specify number of potential cases - 2)

5. OPEN SESSION: 2:00 pm

6. PLEDGE OF ALLEGIANCE: Michael Friese, President

7. ANNOUNCEMENT OF CLOSED SESSION ACTIONS:

8. PUBLIC COMMENTS:

Pursuant to California Government Code Section 54954.3, members of the public may address the Board at this time on any items of public interest that are within the Board's subject matter jurisdiction. The Ralph M. Brown Act, however, prohibits the Board from taking action on any matter not appearing on the agenda. Those who wish to address the Board should come to the microphone. Members of the public will be given three (3) minutes to address the board on any items of public interest. Comments are not to be directed towards an individual or individuals but to the Board on a specific issue.

9. BOARD MEMBER COMMENTS:

10. CONSENT CALENDAR ITEMS:

Consent calendar items are expected to be routine and non-controversial, to be acted upon by the board of directors at one time without discussion. If any board member requests that an item be removed from the consent calendar, it will be removed so that it may be acted upon separately.

A. Approve the Minutes for the Regular Meeting of April 15, 2026 [pg.4]

B. Approve the Minutes for the Special Meeting of April 15, 2026 [pg.8]

C. Approve demands for the month of April 2026. [pg.10]

D. Slovak, Baron, Empey, Murphy, & Pinkney April 2026 (\$12,055.12)

E. Resolution No. 2026-05-20-02

A RESOLUTION OF THE BOARD OF DIRECTORS OF THE SALTON COMMUNITY SERVICES DISTRICT ORDERING AN ELECTION, REQUESTING THE COUNTY ELECTIONS OFFICIAL TO CONDUCT THE ELECTION, AND REQUESTING CONSOLIDATION OF THE ELECTION OF THE SALTON COMMUNITY SERVICES DISTRICT WITH THE OTHER ELECTIONS ON NOVEMBER 3, 2026. [pg.24]

11. REPORTS:

Field Foreman's report [pg.27]

Park Supervisor's report [pg.29]

General Manager's report [pg.30]

Finance Officer's report [pg.31]

12. MEMBERS OF THE BOARD REPORTS: STANDING COMMITTEE:

Architectural Committee Report

13. UNFINISHED BUSINESS:

A. Discussion and approval of Director Reagles' nominee to the Architectural Committee.

14. NEW BUSINESS:

A. Resolution No. 2026-05-20-01

A RESOLUTION OF THE BOARD OF DIRECTORS OF THE SALTON COMMUNITY SERVICES DISTRICT APPROVING THE AGREEMENT REGARDING SPECIAL DISTRICT MEMBERSHIP IN AND FUNDING OF THE IMPERIAL COUNTY LOCAL AGENCY FORMATION COMMISSION. [pg.32]

B. Discussion and approval for the Salton City Park Restroom Restoration Project Bidding Package. [pg.43]

15. Adjournment:

Sonia Thania Garcia, Secretary of the Board

Upon written request, this agenda will be made in an appropriate alternative format to persons with disabilities as required by Section 202 of the American with Disabilities Act of 1990. Any person with a disability who requires a modification or accommodation in order to participate in a meeting should direct such request to the Secretary of the Board at least 72 hours before the meeting. Any public record, relating to an open session agenda item, that is distributed within 72 hours prior to the meeting is available for public inspection at 1209 Van Buren St, Suite 1, Salton City, California 92275.

Salton Community Services District
REGULAR BOARD MEETING *Minutes*

April 15, 2026

Closed Session 1:00 p.m.

Open Session 2:00 p.m.

1209 Van Buren Ave.

Salton City, CA 92275

www.saltoncsd.ca.gov

THIS MEETING IS BEING CONDUCTED AT 1209 VAN BUREN AVE, SALTON CITY, CA 92275. ADDITIONALLY, THIS MEETING IS BEING CONDUCTED BY TELECONFERENCE AT THE FOLLOWING LOCATION: CHAPULTECATE 5 MENA MOCAMPO CENTRO VALLE SANTIAGO C.P. 38400 VALLE DE SANTIAGO, GTO, MEXICO, DIRECTOR RAMOS. PURSUANT TO GOVERNMENT CODE SECTION 54953(b), THE TELECONFERENCE LOCATION IS OPEN TO THE PUBLIC, AND ANY MEMBER OF THE PUBLIC HAS AN OPPORTUNITY TO ADDRESS THE SCSD BOARD FROM A TELECONFERENCE LOCATION IN THE SAME MANNER AS IF THAT PERSON ATTENDED THE REGULAR MEETING LOCATION. THE SCSD BOARD WILL CONTROL THE CONDUCT OF THE MEETING AND DETERMINE THE APPROPRIATE ORDER AND TIME LIMITATIONS ON PUBLIC COMMENTS FROM THE TELECONFERENCE LOCATION.

BOARD OF DIRECTORS:

Michael Friese, President
Oscar Ramirez, Vice President
Manuel Ramos, Director
Lidia A. Sierra, Director
David Reagle, Director

STAFF:

Emmanuel Ramos, General Manager
Christina Sutton, Finance Officer
Thania Garcia, Board Secretary
Jazmine Madrigal, Admin Assistant
Omar Ruiz, Field Foreman
Pascual Muniz, Park Supervisor
Lena Wade, Legal Counsel

1. CALL TO ORDER: 1:00 p.m.

2. ROLL CALL:

President Friese Present	Director Sierra Present
Vice President Ramirez Present	Director Reagle Present
Director Ramos Present [Via Teams]	

3. PUBLIC COMMENTS:

Pursuant to California Government Code Section 54954.3, the public has the right to address the board regarding any closed session items listed on the **closed session agenda** prior to the board adjourning into closed session. Anyone who wishes to address the Board, please come to the microphone. Public comments are limited to (3) minutes for each person. Comments are not to be directed towards an individual or individuals but to the Board on a specific issue.

4. CLOSED SESSION ITEMS:

A. PUBLIC EMPLOYEE DISCIPLINE -DISMISSAL – RELEASE-COMPLAINT – Pursuant to Government Code Section 54957

Please refer to the minutes of the Special Meeting of the Board of Directors that ran concurrently with the Closed Session on April 15, 2026 for a summary of the open session agenda item. There was no reportable action. Thank you.

5. OPEN SESSION: 2:00 pm

6. PLEDGE OF ALLEGIANCE: Michael Friese, President

7. ANNOUNCEMENT OF CLOSED SESSION ACTIONS:

8. PUBLIC COMMENTS:

Pursuant to California Government Code Section 54954.3, members of the public may address the Board at this time on any items of public interest that are within the Board's subject matter jurisdiction. The Ralph M. Brown Act, however, prohibits the Board from taking action on any matter not appearing on the agenda. Those who wish to address the Board should come to the microphone. Members of the public will be given three (3) minutes to address the board on any items of public interest. Comments are not to be directed towards an individual or individuals but to the Board on a specific issue.

Jan Gilson addressed the gathering on the upcoming public hearing concerning land use fees in Imperial County.

Michelle Gilmore informed attendees that Ms. Linsey Dale is scheduled to visit the Senior Center to present important updates regarding changes to voting procedures.

Bennie Hernandez expressed gratitude and generously contributed \$1.00 to support community events.

9. BOARD MEMBER COMMENTS:

President Friese- He provided an update regarding his attendance at the meeting concerning Special Districts joining the LAFCO commission. He noted that he was accompanied by the General Manager and the Board Secretary during this important discussion.

Vice President Ramirez- No comment

Director Ramos- No comment

Director Sierra- No comment

Director Reagle- No comment

10. CONSENT CALENDAR ITEMS:

Consent calendar items are expected to be routine and non-controversial, to be acted upon by the board of directors at one time without discussion. If any board member requests that an item be removed from the consent calendar, it will be removed so that it may be acted upon separately.

A. Approve the Minutes for the Regular Meeting of March 18, 2026

President Friese motioned to approve item A with an amendment to item 2 regarding the Roll Call in the minutes. Vice President Ramirez seconded the motion.

Roll Call:

**President Friese Yes Director Sierra Yes
Vice President Ramirez Yes Director Reagle Yes
Director Ramos Yes**

Motion Passes 5-0

B. Approve demands for the month of March 2026.

C. Slovak, Baron, Empey, Murphy, & Pinkney March (\$4,155.00)

President Friese motioned to approve items B and C from the consent calendar. Director Reagle seconded the motion.

Roll Call:

**President Friese Yes Director Sierra Yes
Vice President Ramirez Yes Director Reagle Yes
Director Ramos Yes**

Motion Passes 5-0

11. REPORTS:

Field Foreman's report [**Omar Ruiz**]
Park Supervisor's report [**Pascual Muniz**]
General Manager's report [**Emmanuel Ramos**]
Finance Officer's report [**Christina Sutton**]

12. MEMBERS OF THE BOARD REPORTS: STANDING COMMITTEE:

Architectural Committee Report
No architectural report because there was no Quorum.

13. UNFINISHED BUSINESS:

A. Discussion and approval of Director Reagles' nominee to the Architectural Committee.
Item tabled.

14. Adjournment:

Board members went into closed session at 2:45 pm

Meeting adjourned at 4:05 pm.

Sonia Thania Garcia, Secretary of the Board

Michael Friese, President of the Board

Upon written request, this agenda will be made in an appropriate alternative format to persons with disabilities as required by Section 202 of the American with Disabilities Act of 1990. Any person with a disability who requires a modification or accommodation in order to participate in a meeting should direct such request to the Secretary of the Board at least 72 hours before the meeting. Any public record, relating to an open session agenda item, that is distributed within 72 hours prior to the meeting is available for public inspection at 1209 Van Buren St, Suite 1, Salton City, California 92275.

Salton Community Services District
SPECIAL MEETING *Minutes*
April 15, 2026

**To run concurrently with the Closed Session on the Agenda for the Regular Meeting
scheduled on April 15, 2026, at 1:00 p.m.**

**1209 Van Buren Ave.
Salton City, CA 92275
www.saltoncsd.ca.gov**

THIS SPECIAL MEETING IS BEING CONDUCTED AT 1209 VAN BUREN AVE, SALTON CITY, CA 92275. ADDITIONALLY, THIS MEETING IS BEING CONDUCTED BY TELECONFERENCE AT THE FOLLOWING LOCATION: CHAPULTECATE 5 MENA MOCAMPO CENTRO VALLE SANTIAGO C.P. 38400 VALLE DE SANTIAGO, GTO, MEXICO, DIRECTOR RAMOS. PURSUANT TO GOVERNMENT CODE SECTION 54953(b), THE TELECONFERENCE LOCATION IS OPEN TO THE PUBLIC, AND ANY MEMBER OF THE PUBLIC HAS AN OPPORTUNITY TO ADDRESS THE SCSD BOARD FROM A TELECONFERENCE LOCATION IN THE SAME MANNER AS IF THAT PERSON ATTENDED THE REGULAR MEETING LOCATION. THE SCSD BOARD WILL CONTROL THE CONDUCT OF THE MEETING AND DETERMINE THE APPROPRIATE ORDER AND TIME LIMITATIONS ON PUBLIC COMMENTS FROM THE TELECONFERENCE LOCATION.

BOARD OF DIRECTORS:

Michael Friese, President
Oscar Ramirez, Vice President
Manuel Ramos, Director
Lidia A. Sierra, Director
David Reagle, Director

STAFF:

Emmanuel Ramos, General Manager
Christina Sutton, Finance Officer
Thania Garcia, Board Secretary
Jazmine Madrigal, Admin Assistant
Omar Ruiz, Field Foreman
Pascual Muniz, Park Supervisor
Lena Wade, Legal Counsel

1. CALL TO ORDER: 1:00 p.m.

2. ROLL CALL:

**President Friese Present Director Sierra Present
Vice President Ramirez Present Director Reagle Present
Director Ramos Present [Via Teams]**

3. PUBLIC COMMENTS:

Pursuant to California Government Code Section 54954.3(3), members of the public may address the Board at this time on any item that has been described in the notice for the Special Meeting before or during consideration of that item. Those who wish to address the Board should come to the microphone. Members of the public will be given three (3) minutes to address the board on any items of public interest. Comments are not to be directed towards an individual or individuals but to the Board on a specific issue.

No comments

4. SPECIAL MEETING OPEN SESSION ITEM:

A. PUBLIC EMPLOYEE DISCIPLINE -DISMISSAL – RELEASE- COMPLAINT

– Pursuant to Government Code Section 54957. According to Government Code Section 549571, on April 13, 2026, Steven Rodriguez, by and through his Union Representative, Nick Gumbleton, provided written notice to the SCSD of Mr. Rodriguez’s election to have the complaint and/ or charges against him heard in open session.

Who presented:

- Christina Sutton summarized the contents of the disciplinary package. [19min:36sec]
- Steven Rodriguez presented a rebuttal. [19min:20sec]
- Nick Gumbleton, union representative, attended, but did not speak,

The Board of Directors had the opportunity to pose questions. President Friese inquired about several points in Mr. Rodriguez's rebuttal. [7 min]

The other directors chose not to ask additional questions.

The parties were provided the opportunity to make closing statements.

President Friese closed this special item, and the Board moved into closed session as set forth on the Regular Meeting agenda.

An audio recording of this meeting is available at the District’s office.

5. Adjournment:

Meeting adjourned at 2:02 pm to continue with the Regular Board Meeting Agenda.

Sonia Thania Garcia, Secretary of the Board

Michael Friese, President of the Board

Upon written request, this agenda will be made in an appropriate alternative format to persons with disabilities as required by Section 202 of the American with Disabilities Act of 1990. Any person with a disability who requires a modification or accommodation in order to participate in a meeting should direct such request to the Secretary of the Board at least 24 hours before the meeting. Any public record, relating to an open session agenda item, that is distributed within 24 hours prior to the meeting is available for public inspection at 1209 Van Buren St, Suite 1, Salton City, California 92275.

Salton Community Services District

Profit and Loss by Class

April 2026

	General Fund	Sewer Construction	Sewer Maintenance	Total
Income				
4-1000 Revenue - GF				
4-1101 Property Tax - Secured - GF	99,184.64			99,184.64
4-1102 Property Tax - Unsecured - GF	-3,008.19			-3,008.19
4-1103 Tax - Homeowners Gen Op				
4-1104 Tax - Supplemental - GF	299.74			299.74
Total for 4-1000 Revenue - GF	96,476.19			\$96,476.19
4-1125 Architectural Plan Fees - GF	50.00			50.00
4-1304 Cell Tower Rent - GF	1,809.46			1,809.46
4-1307 Burrtec Waste Contract - GF	1,108.69			1,108.69
4-1906 ND unspecified dept donations	1.00			1.00
4-2101 Sewer User Charges - SM			255,969.29	255,969.29
4-2102 SM Sewer Connections			3,700.00	3,700.00
4-2103 Sewer Lot Maintenance Fee - SM			40,497.25	40,497.25
4-2104 Interest & Penalties - SM			7,615.22	7,615.22
4-2107 Admin Fees from GF - SM			0.00	0.00
4-2203 Checking Interest Income - SM			1.29	1.29
4-2401 Ste.2 Rental Income - SM (ICFL)			1,040.00	1,040.00
4-2404 ICFL Utility Reimbursement SM			267.40	267.40
4-3203 Checking Interest Income - SC		0.03		0.03
Services	2.85			2.85
Total for Income	99,448.19	0.03	309,090.45	\$408,538.67
Gross Profit	99,448.19	0.03	309,090.45	\$408,538.67
Expenses				
6-1300 Supplies Expense - GF	155.65			155.65
6-1302 GF Internet service expense			250.00	250.00
6-1501 GF Auditing Expense	1,796.87			1,796.87
6-1502 Accounting Services - GF	13,075.00			13,075.00
6-1802 Admin Fees Due to SM - GF	-5,152.76		5,152.76	0.00
6-1849 AD other miscellaneous expense	-34.15			-34.15
6-2003 Street Light Expense - ND	2,015.28			2,015.28
6-2005 Insurance Premiums Expense - ND			2.18	2.18
6-2301 District Legal Expense - ND	6,027.56			6,027.56
6-3201 GF telephone expense	12.24			12.24
6-3207 GF technical expense	115.77			115.77
6-4101 PW Wages Expense			8,887.60	8,887.60
6-4720 PW fuel and oil expense	660.82			660.82

Salton Community Services District

Profit and Loss by Class

April 2026

	General Fund	Sewer Construction	Sewer Maintenance	Total
6-5102 SC Park water service expense	98.64			98.64
6-5103 SC Park electric service exp	174.41			174.41
6-5105 SC Park supplies expense	155.64			155.64
6-5106 SC Park equip/bldg maint. exp	1,890.28			1,890.28
6-5107 SC Park improvement expense				
6-5110 SC Park Grant	-12,158.00			-12,158.00
Total for 6-5107 SC Park improvement expense	-12,158.00			-\$12,158.00
6-5302 DS Park water service expense	363.26			363.26
6-5303 DS Park electric service exp	217.38			217.38
6-5305 DS Park supplies expense	155.65			155.65
6-5307 DS Park improvement expense				
6-5308 DS Park Tree Irrigation Expense	1,492.29			1,492.29
Total for 6-5307 DS Park improvement expense	1,492.29			\$1,492.29
6-5403 Office Electrical Expense			862.60	862.60
6-5503 Duplex/SCSD Lights Electrical Expense	93.38			93.38
6-6101 SM maint. crew wages expense			37,980.82	37,980.82
6-6102 SM employer expense			5,578.42	5,578.42
6-6104 SM health benefits expense			13,539.96	13,539.96
6-6105 Sm retiree health benefits exp			1,817.64	1,817.64
6-6109 SM clerical office wages exp			17,767.84	17,767.84
6-6110 SM administration. (GM) wages			8,461.56	8,461.56
6-6113 SM Directors' Compensation exp			500.00	500.00
6-6204 SM safety supplies expense			2,912.29	2,912.29
6-6206 SM janitorial supplies expense			462.92	462.92
6-6401 SM vehicle maintenance expense			34.48	34.48
6-6402 SM equipment maintenance exp			22.75	22.75
6-6405 SM fuel & oil expense			2,032.35	2,032.35
6-6407 SM shop supplies expense			710.30	710.30
6-6501 SM water service expense			554.55	554.55
6-6502 SM electric service expense			6,283.37	6,283.37
6-6503 SM telephone expense			232.59	232.59
6-6504 SM cell phone expense			1,201.08	1,201.08
6-6505 SM underground alerts expense			147.10	147.10
6-6506 SM internet service expense	250.00			250.00

Salton Community Services District

Profit and Loss by Class

April 2026

	General Fund	Sewer Construction	Sewer Maintenance	Total
6-6508 SM Alarm/Security Expense			3,602.59	3,602.59
6-6713 SM sewer pond maint expense			3,154.73	3,154.73
6-6750 SM lab testing expense			4,847.68	4,847.68
6-6752 SM Engineering Service Expense			2,222.50	2,222.50
6-6761 SM smartcover expense			4,788.00	4,788.00
6-6763 SM - Accounting Services			13,075.00	13,075.00
6-6802 SM Bldg & Grounds Maintenance			7.75	7.75
6-6806 SM Postage Expense			252.00	252.00
6-6811 SM Loan Interest Expense			2,856.67	2,856.67
6-6831 SM Legal Expense			6,027.56	6,027.56
6-6832 SM Auditing Expense			1,796.88	1,796.88
6-6833 SM technical expense			2,199.64	2,199.64
6-6837 SM GASB 75 Actuarial Reports			3,750.00	3,750.00
6-6854 SM/GF Copier Lease/Maint. Expense	606.83		480.82	1,087.65
6-6856 SM Subscriptions Expense	350.00		304.50	654.50
6-6893 SM Breakroom Expense			312.52	312.52
6-6894 SM Payroll Processing Fee Exp.			659.32	659.32
6-7601 GF Duplex Water Service Expense	16.14			16.14
Total for Expenses	12,378.18		165,733.32	\$178,111.50
Net Operating Income	87,070.01	0.03	143,357.13	\$230,427.17
Net Other Income				
Net Income	87,070.01	0.03	143,357.13	\$230,427.17

Salton Community Services District

Transaction Report
April 2026

Transaction date	Transaction type	Num	Name	Description	Full name	Item split account	Amount
6-1300 Supplies Expense - GF							
04/29/2026	Bill		Home Depot	Cleaning Supplies Duplex	6-1300 Supplies Expense - GF	Accounts Payable - SM	155.65
Total for 6-1300 Supplies Expense - GF							\$155.65
6-1302 GF Internet service expense							
04/02/2026	Bill		Frontier Communications	District Office Internet	6-1302 GF Internet service expense	Accounts Payable - SM	250.00
Total for 6-1302 GF Internet service expense							\$250.00
6-1501 GF Auditing Expense							
04/30/2026	Bill	0426-51	O'Connor & Company	For professional services rendered on the above referenced project for the period ending: March 31, 2026	6-1501 GF Auditing Expense	Accounts Payable - SM	1,796.87
Total for 6-1501 GF Auditing Expense							\$1,796.87
6-1502 Accounting Services - GF							
04/14/2026	Bill	116011	The Pun Group	FY2025 State Controller's report	6-1502 Accounting Services - GF	Accounts Payable - SM	1,575.00
04/30/2026	Bill	116065	The Pun Group	FY2025 Government Compensation Report	6-1502 Accounting Services - GF	Accounts Payable - SM	1,500.00
04/30/2026	Bill	116064	The Pun Group	Accounting and Advisory Services for the years ended June 30, 2024 Remaining billing for 2024 Final Billing	6-1502 Accounting Services - GF	Accounts Payable - SM	10,000.00
Total for 6-1502 Accounting Services - GF							\$13,075.00
6-1802 Admin Fees Due to SM - GF							
04/06/2026	Journal Entry	CS040926		Pay Period: 03/30/2026 to: 04/05/2026	6-1802 Admin Fees Due to SM - GF		1,305.86
04/06/2026	Journal Entry	CS040926-3		FY 25-26 to date 10% Wages	6-1802 Admin Fees Due to SM - GF		-1,305.86
04/13/2026	Journal Entry	CS041626		Pay Period: 04/06/2026 to: 04/12/2026	6-1802 Admin Fees Due to SM - GF		1,313.00
04/13/2026	Journal Entry	CS041626-3		FY 25-26 to date 10% Wages	6-1802 Admin Fees Due to SM - GF		-1,313.00
04/17/2026	Journal Entry	CS042326		Pay Period: 04/13/2026 to: 04/19/2026	6-1802 Admin Fees Due to SM - GF		1,306.15
04/20/2026	Journal Entry	CS042326-3		FY 25-26 to date 10% Wages	6-1802 Admin Fees Due to SM - GF		-1,306.15
04/23/2026	Journal Entry	CS042326-4		Imperial County Tax Roll Warrant 808985	6-1802 Admin Fees Due to SM - GF		6,753.33
04/23/2026	Journal Entry	CS042326-5		7% Admin Fee From Imperial County GF Check	6-1802 Admin Fees Due to SM - GF		-6,753.33
04/24/2026	Journal Entry	CS043026		Pay Period: 04/20/2026 to: 04/26/2026	6-1802 Admin Fees Due to SM - GF		1,227.75
04/27/2026	Journal Entry	CS043026-3		FY 25-26 to date 10% Wages	6-1802 Admin Fees Due to SM - GF		-1,227.75
Total for 6-1802 Admin Fees Due to SM - GF							\$0.00
6-1849 AD other miscellaneous expense							
04/14/2026	Check	ACH		Misc charge	6-1849 AD other miscellaneous expense	General Fund	29.94
04/17/2026	Check	ACH		Unauthorized Charge - Will Be refunded by bank	6-1849 AD other miscellaneous expense	General Fund	10.19
04/22/2026	Deposit			Bank Refund for Unauthorized charges	6-1849 AD other miscellaneous expense	General Fund	-40.13

Salton Community Services District

Transaction Report
April 2026

Transaction date	Transaction type	Num	Name	Description	Full name	Item split account	Amount
04/28/2026	Deposit			Unauthorized Charge reversed	6-1849 AD other miscellaneous expense	General Fund	-34.15
Total for 6-1849 AD other miscellaneous expense							-\$34.15
6-2003 Street Light Expense - ND							
04/09/2026	Bill		IID	SC Street Lights Electrical Service Expense Account# ****7900	6-2003 Street Light Expense - ND	Accounts Payable - SM	2,015.28
Total for 6-2003 Street Light Expense - ND							\$2,015.28
6-2005 Insurance Premiums Expense - ND							
04/01/2026	Bill	79720	Special District Risk Management Auth.	FY 2025-2026 PL Interim Invoice	6-2005 Insurance Premiums Expense - ND	Accounts Payable - SM	2.18
Total for 6-2005 Insurance Premiums Expense - ND							\$2.18
6-2301 District Legal Expense - ND							
04/30/2026	Bill	100470	Slovak Baron Empey Murphy & Pinkney	Legal Services Through 04/30/26	6-2301 District Legal Expense - ND	Accounts Payable - SM	6,027.56
Total for 6-2301 District Legal Expense - ND							\$6,027.56
6-3201 GF telephone expense							
04/29/2026	Bill		Cytracom	District Office Monthly Phone Service Bill	6-3201 GF telephone expense	Accounts Payable - SM	12.24
Total for 6-3201 GF telephone expense							\$12.24
6-3207 GF technical expense							
04/01/2026	Bill	3033-04012026-49	Interconnect Networks	Tech Support Monthly Bill/Expenses	6-3207 GF technical expense	Accounts Payable - SM	115.77
Total for 6-3207 GF technical expense							\$115.77
6-4101 PW Wages Expense							
04/06/2026	Journal Entry	CS040926-2		Payroll accrual 04/05/26	6-4101 PW Wages Expense		2,249.52
04/13/2026	Journal Entry	CS041626-2		Payroll accrual 04/12/26	6-4101 PW Wages Expense		2,243.29
04/17/2026	Journal Entry	CS042326-2		Payroll accrual 04/19/26	6-4101 PW Wages Expense		2,197.60
04/24/2026	Journal Entry	CS043026-2		Payroll accrual 04/26/26	6-4101 PW Wages Expense		2,197.19
Total for 6-4101 PW Wages Expense							\$8,887.60
6-4720 PW fuel and oil expense							
04/15/2026	Bill	208493	Beck Oil, Inc.	Fuel Card Expense-GF	6-4720 PW fuel and oil expense	Accounts Payable - SM	193.65
04/30/2026	Bill	210450	Beck Oil, Inc.	Fuel Card Expense-GF	6-4720 PW fuel and oil expense	Accounts Payable - SM	467.17
Total for 6-4720 PW fuel and oil expense							\$660.82
6-5102 SC Park water service expense							
04/01/2026	Bill		CVWD	SC Park Water Service Account# 106457-145806	6-5102 SC Park water service expense	Accounts Payable - SM	40.48
04/30/2026	Bill		CVWD	SC Park Water Service Account# 106457-145806	6-5102 SC Park water service expense	Accounts Payable - SM	58.16
Total for 6-5102 SC Park water service expense							\$98.64

Salton Community Services District

Transaction Report
April 2026

Transaction date	Transaction type	Num	Name	Description	Full name	Item split account	Amount
6-5103 SC Park electric service exp							
04/07/2026	Bill		IID	Electrical Expense Account# ****7986	6-5103 SC Park electric service exp	Accounts Payable - SM	174.41
Total for 6-5103 SC Park electric service exp							\$174.41
6-5105 SC Park supplies expense							
04/29/2026	Bill		Home Depot	Cleaning Supplies	6-5105 SC Park supplies expense	Accounts Payable - SM	155.64
Total for 6-5105 SC Park supplies expense							\$155.64
6-5106 SC Park equip/bldg maint. exp							
04/07/2026	Bill	2026-0088	Creative Shade Solutions	Replacement Shade Cover	6-5106 SC Park equip/bldg maint. exp	Accounts Payable - SM	329.83
04/08/2026	Bill	2026-0088	Creative Shade Solutions	Replacement Shade Cover	6-5106 SC Park equip/bldg maint. exp	Accounts Payable - SM	1,560.45
Total for 6-5106 SC Park equip/bldg maint. exp							\$1,890.28
6-5302 DS Park water service expense							
04/03/2026	Bill		CVWD	DS Park Water Service Expense Account# 100569-101606	6-5302 DS Park water service expense	Accounts Payable - SM	363.26
Total for 6-5302 DS Park water service expense							\$363.26
6-5303 DS Park electric service exp							
04/07/2026	Bill		IID	Desert Shores Park Electrical Expense Account# ****6177	6-5303 DS Park electric service exp	Accounts Payable - SM	217.38
Total for 6-5303 DS Park electric service exp							\$217.38
6-5305 DS Park supplies expense							
04/29/2026	Bill		Home Depot	Cleaning Supplies	6-5305 DS Park supplies expense	Accounts Payable - SM	155.65
Total for 6-5305 DS Park supplies expense							\$155.65
6-5403 Office Electrical Expense							
04/07/2026	Bill		IID	Electrical Service Expense suite 1,2, 3, 5 Account# ****8778 Suite 2 Account# ****8757 Suite 5 Account# ****2673 Suite 3 Account# ****8777 Suite 1	6-5403 Office Electrical Expense	Accounts Payable - SM	862.60
Total for 6-5403 Office Electrical Expense							\$862.60
6-5503 Duplex/SCSD Lights Electrical Expense							
04/07/2026	Bill		IID	DS Drive Entrance Lights Account# ****9659	6-5503 Duplex/SCSD Lights Electrical Expense	Accounts Payable - SM	23.16
04/07/2026	Bill		IID	Duplex Electrical Expense Account# ****8496	6-5503 Duplex/SCSD Lights Electrical Expense	Accounts Payable - SM	47.72
04/07/2026	Bill		IID	SC Entrance Lights Electrical Service Expense Account# ****3794	6-5503 Duplex/SCSD Lights Electrical Expense	Accounts Payable - SM	22.50
Total for 6-5503 Duplex/SCSD Lights Electrical Expense							\$93.38

Salton Community Services District

Transaction Report
April 2026

Transaction date	Transaction type	Num	Name	Description	Full name	Item split account	Amount
6-6101 SM maint. crew wages expense							
04/06/2026	Journal Entry	CS040926-2		Payroll accrual 04/05/26	6-6101 SM maint. crew wages expense		9,755.06
04/13/2026	Journal Entry	CS041626-2		Payroll accrual 04/12/26	6-6101 SM maint. crew wages expense		8,697.15
04/17/2026	Journal Entry	CS042326-2		Payroll accrual 04/19/26	6-6101 SM maint. crew wages expense		8,477.00
04/24/2026	Journal Entry	CS043026-2		Payroll accrual 04/26/26	6-6101 SM maint. crew wages expense		11,051.61
Total for 6-6101 SM maint. crew wages expense							\$37,980.82
6-6102 SM employer expense							
04/06/2026	Journal Entry	CS040926-2		Payroll accrual 04/05/26	6-6102 SM employer expense		1,336.26
04/13/2026	Journal Entry	CS041626-2		Payroll accrual 04/12/26	6-6102 SM employer expense		1,341.32
04/17/2026	Journal Entry	CS042326-2		Payroll accrual 04/19/26	6-6102 SM employer expense		1,386.58
04/24/2026	Journal Entry	CS043026-2		Payroll accrual 04/26/26	6-6102 SM employer expense		1,514.26
Total for 6-6102 SM employer expense							\$5,578.42
6-6104 SM health benefits expense							
04/01/2026	Bill		Laborers Health & Welfare Trust So. CA	March 2026 Health Insurance	6-6104 SM health benefits expense	Accounts Payable - SM	13,539.96
Total for 6-6104 SM health benefits expense							\$13,539.96
6-6105 Sm retiree health benefits exp							
04/01/2026	Check	1780	Fair, Gloria L.	Retiree Health Benefit for the Month of May 2026	6-6105 Sm retiree health benefits exp	Sewer Maintenance	405.33
04/01/2026	Check	1781	Robert Dunning	Retiree Health Benefit for the Month of May 2026	6-6105 Sm retiree health benefits exp	Sewer Maintenance	500.00
04/01/2026	Check	1782	Thompson, Janice	Retiree Health Benefit for the Month of May 2026	6-6105 Sm retiree health benefits exp	Sewer Maintenance	209.41
04/01/2026	Check	1783	Freeman, Mr. Blake	Retiree Health Benefit for the Month of May 2026	6-6105 Sm retiree health benefits exp	Sewer Maintenance	500.00
04/01/2026	Check	1785	Timothy A. Roberts	Retiree Health Benefit for the Month of May 2026	6-6105 Sm retiree health benefits exp	Sewer Maintenance	202.90
Total for 6-6105 Sm retiree health benefits exp							\$1,817.64
6-6109 SM clerical office wages exp							
04/06/2026	Journal Entry	CS040926-2		Payroll accrual 04/05/26	6-6109 SM clerical office wages exp		4,430.00
04/13/2026	Journal Entry	CS041626-2		Payroll accrual 04/12/26	6-6109 SM clerical office wages exp		4,477.84
04/17/2026	Journal Entry	CS042326-2		Payroll accrual 04/19/26	6-6109 SM clerical office wages exp		4,430.00
04/24/2026	Journal Entry	CS043026-2		Payroll accrual 04/26/26	6-6109 SM clerical office wages exp		4,430.00
Total for 6-6109 SM clerical office wages exp							\$17,767.84
6-6110 SM administration. (GM) wages							
04/06/2026	Journal Entry	CS040926-2		Payroll accrual 04/05/26	6-6110 SM administration. (GM) wages		2,115.39
04/13/2026	Journal Entry	CS041626-2		Payroll accrual 04/12/26	6-6110 SM administration. (GM) wages		2,115.39
04/17/2026	Journal Entry	CS042326-2		Payroll accrual 04/19/26	6-6110 SM administration. (GM) wages		2,115.39
04/24/2026	Journal Entry	CS043026-2		Payroll accrual 04/26/26	6-6110 SM administration. (GM) wages		2,115.39
Total for 6-6110 SM administration. (GM) wages							\$8,461.56

Salton Community Services District

Transaction Report
April 2026

Transaction date	Transaction type	Num	Name	Description	Full name	Item split account	Amount
6-6113 SM Directors' Compensation exp							
04/17/2026	Journal Entry	CS042326-2		Payroll accrual 04/19/26	6-6113 SM Directors' Compensation exp		500.00
Total for 6-6113 SM Directors' Compensation exp							\$500.00
6-6204 SM safety supplies expense							
04/27/2026	Bill	INV35425	HAAKER	Gas meters for entering confined spaces	6-6204 SM safety supplies expense	Accounts Payable - SM	2,912.29
Total for 6-6204 SM safety supplies expense							\$2,912.29
6-6206 SM janitorial supplies expense							
04/03/2026	Invoice	1706	Imperial County Free Library	Paper towels and Toilet Paper	6-6206 SM janitorial supplies expense	Accounts Receivable	0.00
04/14/2026	Invoice	1716	Imperial County Free Library	Paper towels and Toilet Paper	6-6206 SM janitorial supplies expense	Accounts Receivable	0.00
04/29/2026	Bill		Home Depot	Cleaning Supplies for District office	6-6206 SM janitorial supplies expense	Accounts Payable - SM	351.23
04/29/2026	Bill		Home Depot	Cleaning Supplies for Shop	6-6206 SM janitorial supplies expense	Accounts Payable - SM	111.69
Total for 6-6206 SM janitorial supplies expense							\$462.92
6-6401 SM vehicle maintenance expense							
04/01/2026	Bill		Steve's ATV/Napa Auto Parts	Unit 4 -Turnsignal bulbs	6-6401 SM vehicle maintenance expense	Accounts Payable - SM	34.48
Total for 6-6401 SM vehicle maintenance expense							\$34.48
6-6402 SM equipment maintenance exp							
04/23/2026	Bill	17689	Steve's ATV/Napa Auto Parts	Unit 53 - Nuts & Bolts for leaf spring retainer clamp	6-6402 SM equipment maintenance exp	Accounts Payable - SM	22.75
Total for 6-6402 SM equipment maintenance exp							\$22.75
6-6405 SM fuel & oil expense							
04/15/2026	Bill	208493	Beck Oil, Inc.	Fuel Card Expense-SM	6-6405 SM fuel & oil expense	Accounts Payable - SM	1,026.31
04/30/2026	Bill	210450	Beck Oil, Inc.	Fuel Card Expense-SM	6-6405 SM fuel & oil expense	Accounts Payable - SM	1,006.04
Total for 6-6405 SM fuel & oil expense							\$2,032.35
6-6407 SM shop supplies expense							
04/29/2026	Bill		Home Depot	Chlorine for disinfection for spills, shop vac filter, N95 masks	6-6407 SM shop supplies expense	Accounts Payable - SM	710.30
Total for 6-6407 SM shop supplies expense							\$710.30
6-6501 SM water service expense							
04/02/2026	Bill		CVWD	District Water Service-Office Account# 597961-732634	6-6501 SM water service expense	Accounts Payable - SM	31.09
04/02/2026	Bill		CVWD	District Water Service-Office Irrigation Account# 597959-732636	6-6501 SM water service expense	Accounts Payable - SM	30.78
04/03/2026	Bill		CVWD	District Shop Water Service Expense Account# 106235-143472	6-6501 SM water service expense	Accounts Payable - SM	20.22

Salton Community Services District

Transaction Report
April 2026

Transaction date	Transaction Num type	Name	Description	Full name	Item split account	Amount
04/03/2026	Bill	CVWD	Sewer Jet Water Service Expense Account# 273741-732668	6-6501 SM water service expense	Accounts Payable - SM	100.12
04/06/2026	Bill	CVWD	Vactor Truck Water Service Expense Account# 273739-732666	6-6501 SM water service expense	Accounts Payable - SM	64.86
04/20/2026	Bill	CVWD	Construction Meter	6-6501 SM water service expense	Accounts Payable - SM	130.44
04/30/2026	Bill	CVWD	District Shop Water Service Expense Account# 106235-143472	6-6501 SM water service expense	Accounts Payable - SM	21.58
04/30/2026	Bill	CVWD	Vactor Truck Water Service Expense Account# 273739-732666	6-6501 SM water service expense	Accounts Payable - SM	55.34
04/30/2026	Bill	CVWD	Sewer Jet Water Service Expense Account# 273741-732668	6-6501 SM water service expense	Accounts Payable - SM	100.12
Total for 6-6501 SM water service expense						\$554.55
6-6502 SM electric service expense						
04/07/2026	Bill	IID	Station# 7 Monthly Electricity Expense Account# ****4645	6-6502 SM electric service expense	Accounts Payable - SM	37.85
04/07/2026	Bill	IID	DS Ponds Monthly Electricity Expense Account# ****3804	6-6502 SM electric service expense	Accounts Payable - SM	1,031.30
04/07/2026	Bill	IID	Station# 8 Monthly Electricity Expense Account# ****3786	6-6502 SM electric service expense	Accounts Payable - SM	118.49
04/07/2026	Bill	IID	Station# 1 Monthly Electricity Expense Account# ****8017	6-6502 SM electric service expense	Accounts Payable - SM	24.50
04/07/2026	Bill	IID	Station# 2 Monthly Electricity Expense Account# ****8036	6-6502 SM electric service expense	Accounts Payable - SM	320.14
04/07/2026	Bill	IID	Station# 13 Monthly Electricity Expense Account# ****7969	6-6502 SM electric service expense	Accounts Payable - SM	33.43
04/07/2026	Bill	IID	Station# 19-20 Monthly Electricity Expense Account# ****7933	6-6502 SM electric service expense	Accounts Payable - SM	77.41
04/07/2026	Bill	IID	District Shop Monthly Electricity Expense Account# ****7893	6-6502 SM electric service expense	Accounts Payable - SM	273.68
04/07/2026	Bill	IID	Station# 10 Monthly Electricity Expense Account# ****7977	6-6502 SM electric service expense	Accounts Payable - SM	314.29
04/07/2026	Bill	IID	Station# 15 Monthly Electricity Expense Account# ****7959	6-6502 SM electric service expense	Accounts Payable - SM	244.36
04/07/2026	Bill	IID	Station# 16 Monthly Electricity Expense Account# ****5317	6-6502 SM electric service expense	Accounts Payable - SM	504.66
04/07/2026	Bill	IID	Station# 24-240 Volt STBY Monthly Electricity Expense Account# ****7916	6-6502 SM electric service expense	Accounts Payable - SM	24.50
04/07/2026	Bill	IID	Station# 5 Monthly Electricity Expense Account# ****7993	6-6502 SM electric service expense	Accounts Payable - SM	115.04
04/07/2026	Bill	IID	Station# 17-18 Monthly Electricity Expense Account# ****7941	6-6502 SM electric service expense	Accounts Payable - SM	71.05
04/07/2026	Bill	IID	Station# 12 Monthly Electricity Expense Account# ****3692	6-6502 SM electric service expense	Accounts Payable - SM	22.50
04/07/2026	Bill	IID	Station# 6 Monthly Electricity Expense Account# ****9623	6-6502 SM electric service expense	Accounts Payable - SM	55.61

Salton Community Services District

Transaction Report
April 2026

Transaction date	Transaction type	Num	Name	Description	Full name	Item split account	Amount
04/07/2026	Bill		IID	Station# 24-480 Volt Monthly Electricity Expense Account# ****1442	6-6502 SM electric service expense	Accounts Payable - SM	803.76
04/07/2026	Bill		IID	Lansing Ponds Monthly Electricity Expense Account# ****1216	6-6502 SM electric service expense	Accounts Payable - SM	1,378.46
04/07/2026	Bill		IID	Station# 21 Monthly Electricity Expense Account# ****7292	6-6502 SM electric service expense	Accounts Payable - SM	28.28
04/07/2026	Bill		IID	Station# 22-B Monthly Electricity Expense Account# ****1441	6-6502 SM electric service expense	Accounts Payable - SM	256.23
04/09/2026	Bill		IID	TRC Ponds Monthly Electricity Expense Account# ****1443	6-6502 SM electric service expense	Accounts Payable - SM	331.75
04/14/2026	Bill		IID	Station# 23 & Lansing Monthly Electricity Expense Account# ****7907	6-6502 SM electric service expense	Accounts Payable - SM	216.08
Total for 6-6502 SM electric service expense							\$6,283.37
6-6503 SM telephone expense							
04/29/2026	Bill		Cytracom	District Office Monthly Phone Service Bill	6-6503 SM telephone expense	Accounts Payable - SM	232.59
Total for 6-6503 SM telephone expense							\$232.59
6-6504 SM cell phone expense							
04/22/2026	Bill		Ooma.com	Station 24 Alert Monitoring phone line service	6-6504 SM cell phone expense	Accounts Payable - SM	29.99
04/24/2026	Bill		Ooma.com	Station 16 Alert Monitoring phone line service	6-6504 SM cell phone expense	Accounts Payable - SM	29.99
04/25/2026	Bill	6142004653	Verizon Wireless	Company Cell phone, Tablet Service Account# 542131140-00001	6-6504 SM cell phone expense	Accounts Payable - SM	1,081.12
04/27/2026	Bill		Ooma.com	Station 22 Alert Monitoring phone line service	6-6504 SM cell phone expense	Accounts Payable - SM	29.99
04/29/2026	Bill		Ooma.com	Station 2 Alert Monitoring phone line service	6-6504 SM cell phone expense	Accounts Payable - SM	29.99
Total for 6-6504 SM cell phone expense							\$1,201.08
6-6505 SM underground alerts expense							
04/01/2026	Bill	320260656	Underground Service Alert/SC	50 Dig Alerts @ 2.15	6-6505 SM underground alerts expense	Accounts Payable - SM	107.50
04/01/2026	Bill	320260656	Underground Service Alert/SC	Monthly Database Maintenance fee	6-6505 SM underground alerts expense	Accounts Payable - SM	10.00
04/01/2026	Bill	25-263358	Underground Service Alert/SC	California State Fee for Regulatory Costs** California Underground Facilities Safe Excavation Board Operational Expenses - \$5,250,000 Statewide Billable (New) Tickets 2024 - 7,509,386	6-6505 SM underground alerts expense	Accounts Payable - SM	29.60
Total for 6-6505 SM underground alerts expense							\$147.10
6-6506 SM internet service expense							
04/02/2026	Bill		Frontier Communications	District Office Internet	6-6506 SM internet service expense	Accounts Payable - SM	250.00
Total for 6-6506 SM internet service expense							\$250.00

Salton Community Services District

Transaction Report
April 2026

Transaction date	Transaction type	Num	Name	Description	Full name	Item split account	Amount
6-6508 SM Alarm/Security Expense							
04/01/2026	Bill	586293	Desert Alarm Inc.	Alarm Security	6-6508 SM Alarm/Security Expense	Accounts Payable - SM	134.85
04/15/2026	Bill		Desert Alarm Inc.	Alarm System District Office	6-6508 SM Alarm/Security Expense	Accounts Payable - SM	3,372.74
04/15/2026	Bill		Desert Alarm Inc.	Shop - Door Alarm Sensor Repair	6-6508 SM Alarm/Security Expense	Accounts Payable - SM	95.00
Total for 6-6508 SM Alarm/Security Expense							\$3,602.59
6-6713 SM sewer pond maint expense							
04/01/2026	Bill	1664	BIOALCHEMY INC.	Bioaugmentation	6-6713 SM sewer pond maint expense	Accounts Payable - SM	2,138.84
04/15/2026	Bill		Grainger	Bailers used for Monthly pond Sampling	6-6713 SM sewer pond maint expense	Accounts Payable - SM	475.51
04/23/2026	Bill	INV01028287	USA BlueBook	membranes needed for DO Sensor used regularly for pond testing	6-6713 SM sewer pond maint expense	Accounts Payable - SM	540.38
Total for 6-6713 SM sewer pond maint expense							\$3,154.73
6-6750 SM lab testing expense							
04/05/2026	Bill	CD60172-9867	Babcock Laboratories, Inc. Accounts Receivable	TRC Monthly Pond Samples	6-6750 SM lab testing expense	Accounts Payable - SM	189.87
04/05/2026	Bill	CD60171-9867	Babcock Laboratories, Inc. Accounts Receivable	Desert Shores Monthly Pond Samples	6-6750 SM lab testing expense	Accounts Payable - SM	285.38
04/05/2026	Bill	CD60155-9867	Babcock Laboratories, Inc. Accounts Receivable	Lansing Monthly Pond Samples	6-6750 SM lab testing expense	Accounts Payable - SM	308.97
04/05/2026	Bill	CD60499-9867	Babcock Laboratories, Inc. Accounts Receivable	TRC Quarterly Water Well Samples	6-6750 SM lab testing expense	Accounts Payable - SM	2,391.00
04/05/2026	Bill	CD60151-9867	Babcock Laboratories, Inc. Accounts Receivable	TRC, Lansing, Desert Shores Quarterly Pond Samples	6-6750 SM lab testing expense	Accounts Payable - SM	337.05
04/12/2026	Bill	LD600616-9867	Babcock Laboratories, Inc. Accounts Receivable	Desert Shores Monthly Water Samples	6-6750 SM lab testing expense	Accounts Payable - SM	527.60
04/15/2026	Bill	CD60644-9867	Babcock Laboratories, Inc. Accounts Receivable	TRC Monthly Pond Samples	6-6750 SM lab testing expense	Accounts Payable - SM	189.87
04/15/2026	Bill	CD60643-9867	Babcock Laboratories, Inc. Accounts Receivable	Lansing Monthly Pond Samples	6-6750 SM lab testing expense	Accounts Payable - SM	308.97
04/15/2026	Bill	CD60642-9867	Babcock Laboratories, Inc. Accounts Receivable	Desert Shores Monthly Pond Samples	6-6750 SM lab testing expense	Accounts Payable - SM	308.97
Total for 6-6750 SM lab testing expense							\$4,847.68
6-6752 SM Engineering Service Expense							
04/10/2026	Bill	2026-270	TKE Engineering, Inc	TKE 157-06 WDR Regulatory Support	6-6752 SM Engineering Service Expense	Accounts Payable - SM	1,612.50
04/14/2026	Bill	2026-406	TKE Engineering, Inc	TKE 157-06 WDR Regulatory Support	6-6752 SM Engineering Service Expense	Accounts Payable - SM	610.00
Total for 6-6752 SM Engineering Service Expense							\$2,222.50

Salton Community Services District

Transaction Report
April 2026

Transaction date	Transaction type	Num	Name	Description	Full name	Item split account	Amount
6-6761 SM smartcover expense							
04/23/2026	Bill	1801416	SmartCover Systems, Inc.	Smart Cover Renewal FY 26-27	6-6761 SM smartcover expense	Accounts Payable - SM	4,788.00
Total for 6-6761 SM smartcover expense							\$4,788.00
6-6763 SM - Accounting Services							
04/14/2026	Bill	116011	The Pun Group	FY2025 State Controller's report	6-6763 SM - Accounting Services	Accounts Payable - SM	1,575.00
04/30/2026	Bill	116065	The Pun Group	FY2025 Government Compensation Report	6-6763 SM - Accounting Services	Accounts Payable - SM	1,500.00
04/30/2026	Bill	116064	The Pun Group	Accounting and Advisory Services for the years ended June 30, 2024 Remaining billing for 2024 Final Billing	6-6763 SM - Accounting Services	Accounts Payable - SM	10,000.00
Total for 6-6763 SM - Accounting Services							\$13,075.00
6-6802 SM Bldg & Grounds Maintenance							
04/01/2026	Bill		Steve's ATV/Napa Auto Parts	Copies of keys for the shop building	6-6802 SM Bldg & Grounds Maintenance	Accounts Payable - SM	7.75
Total for 6-6802 SM Bldg & Grounds Maintenance							\$7.75
6-6806 SM Postage Expense							
04/13/2026	Check	1805	US Postal Service	PO Box 5268 Annual Fee	6-6806 SM Postage Expense	Sewer Maintenance	152.00
04/27/2026	Bill		Quadient Finance USA - Postage	Postage	6-6806 SM Postage Expense	Accounts Payable - SM	100.00
Total for 6-6806 SM Postage Expense							\$252.00
6-6811 SM Loan Interest Expense							
04/01/2026	Check	1786	Salton Sea Enterprises, LLC.	Loan Interest Payable 2026	6-6811 SM Loan Interest Expense	Sewer Maintenance	2,856.67
Total for 6-6811 SM Loan Interest Expense							\$2,856.67
6-6831 SM Legal Expense							
04/30/2026	Bill	100470	Slovak Baron Empey Murphy & Pinkney	Legal Services Through 04/30/26	6-6831 SM Legal Expense	Accounts Payable - SM	6,027.56
Total for 6-6831 SM Legal Expense							\$6,027.56
6-6832 SM Auditing Expense							
04/30/2026	Bill	0426-51	O'Connor & Company	For professional services rendered on the above referenced project for the period ending: March 31, 2026	6-6832 SM Auditing Expense	Accounts Payable - SM	1,796.88
Total for 6-6832 SM Auditing Expense							\$1,796.88
6-6833 SM technical expense							
04/01/2026	Bill	3033-04012026-49	Interconnect Networks	Tech Support Monthly Bill/Expenses	6-6833 SM technical expense	Accounts Payable - SM	2,199.64
Total for 6-6833 SM technical expense							\$2,199.64
6-6837 SM GASB 75 Actuarial Reports							
04/17/2026	Bill	41331	Foster & Foster	Preparation of GASB 75 Table Updates for the fiscal year ending 6/30/2024	6-6837 SM GASB 75 Actuarial Reports	Accounts Payable - SM	3,750.00
Total for 6-6837 SM GASB 75 Actuarial Reports							\$3,750.00

Salton Community Services District

Transaction Report
April 2026

Transaction date	Transaction type	Num	Name	Description	Full name	Item split account	Amount
6-6854 SM/GF Copier Lease/Maint. Expense							
04/16/2026	Bill	41906975	Xerox Financial Services	Copier Machine Lease	6-6854 SM/GF Copier Lease/Maint. Expense	Accounts Payable - SM	480.82
04/20/2026	Bill	24AR3462579	Visual Edge IT, Inc.	Monthly Charge for Printing	6-6854 SM/GF Copier Lease/Maint. Expense	Accounts Payable - SM	606.83
Total for 6-6854 SM/GF Copier Lease/Maint. Expense							\$1,087.65
6-6856 SM Subscriptions Expense							
04/01/2026	Bill	FE8F35D0-0067	Streamline	Website Hosting Bill	6-6856 SM Subscriptions Expense	Accounts Payable - SM	350.00
04/10/2026	Bill		RemotePC.com	Annual Remote Access software	6-6856 SM Subscriptions Expense	Accounts Payable - SM	29.50
04/21/2026	Bill		Intuit	QuickBooks Monthly Expense	6-6856 SM Subscriptions Expense	Accounts Payable - SM	275.00
Total for 6-6856 SM Subscriptions Expense							\$654.50
6-6893 SM Breakroom Expense							
04/09/2026	Bill		Costco Wholesale	48 cases of bottled water for district office	6-6893 SM Breakroom Expense	Accounts Payable - SM	312.52
Total for 6-6893 SM Breakroom Expense							\$312.52
6-6894 SM Payroll Processing Fee Exp.							
04/03/2026	Check	ACH	ADP	Payroll Processing Fee	6-6894 SM Payroll Processing Fee Exp.	Sewer Maintenance	109.22
04/03/2026	Check	ACH	ADP	Payroll Processing Fee	6-6894 SM Payroll Processing Fee Exp.	Sewer Maintenance	96.38
04/10/2026	Check	ACH	ADP	Payroll Processing Fee	6-6894 SM Payroll Processing Fee Exp.	Sewer Maintenance	93.44
04/17/2026	Check	ACH	ADP	Payroll Processing Fee	6-6894 SM Payroll Processing Fee Exp.	Sewer Maintenance	87.12
04/17/2026	Check	ACH	ADP	Payroll Processing Fee	6-6894 SM Payroll Processing Fee Exp.	Sewer Maintenance	179.72
04/24/2026	Check	ACH	ADP	Payroll Processing Fee	6-6894 SM Payroll Processing Fee Exp.	Sewer Maintenance	93.44
Total for 6-6894 SM Payroll Processing Fee Exp.							\$659.32
6-7601 GF Duplex Water Service Expense							
04/03/2026	Bill		CVWD	DS Building Water Service-Duplex Account# 710799-100642	6-7601 GF Duplex Water Service Expense	Accounts Payable - SM	16.14
Total for 6-7601 GF Duplex Water Service Expense							\$16.14
6-5107 SC Park improvement expense							
6-5110 SC Park Grant							
04/08/2026	Bill	25050-005	Hermann Design Group, Inc.	Project 25050 - Bathroom Renovation Feb 1, 2026 - Mar 31, 2026	6-5107 SC Park improvement expense:6-5110 SC Park Grant	Accounts Payable - SM	2,185.00
04/21/2026	Deposit		California Department of Parks & Recreation	SC Park Grant Reimbursement	6-5107 SC Park improvement expense:6-5110 SC Park Grant	General Fund	-14,343.00
Total for 6-5110 SC Park Grant							-\$12,158.00
Total for 6-5107 SC Park improvement expense with sub-accounts							-\$12,158.00

Salton Community Services District

Transaction Report
April 2026

Transaction date	Transaction Num type	Name	Description	Full name	Item split account	Amount
6-5307 DS Park improvement expense						
6-5308 DS Park Tree Irrigation Expense 04/29/2026	Bill	Home Depot	Sprinkler irrigation system for watering Trees	6-5307 DS Park improvement expense:6-5308 DS Park Tree Irrigation Expense	Accounts Payable - SM	1,492.29
Total for 6-5308 DS Park Tree Irrigation Expense						\$1,492.29
Total for 6-5307 DS Park improvement expense with sub-accounts						\$1,492.29
TOTAL						\$178,111.50



Salton Community Services District

MEETING DATE: 05/20/2026 Item Number: 10. E

Staff Report: Resolution No. 2026-05-20-02

A RESOLUTION OF THE BOARD OF DIRECTORS OF THE SALTON COMMUNITY SERVICES DISTRICT ORDERING AN ELECTION, REQUESTING THE COUNTY ELECTIONS OFFICIAL TO CONDUCT THE ELECTION, AND REQUESTING CONSOLIDATION OF THE ELECTION OF THE SALTON COMMUNITY SERVICES DISTRICT WITH THE OTHER ELECTIONS ON NOVEMBER 3, 2026

To: Board of Directors

From: District Administration

RECOMMENDATION:

It is recommended that the Board of Directors adopt Resolution No. 2026-05-20-02, ordering an election for three (3) Directors at Large, requesting that the Imperial County Registrar of Voters conduct said election, and requesting consolidation with other elections held on November 3, 2026.

Background

The district is scheduled to hold an election on November 3, 2026, to fill three seats, each carrying a four-year term. Per the California Elections Code, the district must formally request that the County of Imperial conduct and consolidate this vote with other local and statewide elections. This request, as outlined in the Resolution No. 2026-05-20-02, requires the board to submit a resolution to the County Board of Supervisors at least 88 days prior to the election date.

Fiscal Impact

By adopting this resolution, the district agrees to reimburse the County of Imperial in full for all services performed by the Elections Department upon presentation of a bill. Consolidation of elections typically results in a cost-sharing benefit, reducing the overall financial burden.

RESOLUTION NO. 2026-05-20-02

A RESOLUTION OF THE BOARD OF DIRECTORS OF THE SALTON COMMUNITY SERVICES DISTRICT ORDERING AN ELECTION, REQUESTING THE COUNTY ELECTIONS OFFICIAL TO CONDUCT THE ELECTION, AND REQUESTING CONSOLIDATION OF THE ELECTION OF THE SALTON COMMUNITY SERVICES DISTRICT WITH THE OTHER ELECTIONS ON NOVEMBER 3, 2026

WHEREAS, pursuant to Elections Code Section 10002, the governing body of any city or district may by resolution request the Board of Supervisors of the county to permit the county elections official to render specified services to the city or district relating to the conduct of any election; and

WHEREAS, this resolution of the governing body of the city or district shall specify the services requested; and

WHEREAS, pursuant to Elections Code Section 10002, the city or district shall reimburse the county in full for the services performed upon presentation of a bill to the city or district; and

WHEREAS, pursuant to Elections Code Section 10400, whenever two or more elections including bond elections, of any legislative or congressional district, public district, city, county or other political subdivision are called to be held on the same day, in the same territory, or in territory that is in part the same, they may be consolidated upon the order of the governing body or bodies or officer or officers calling the election;

WHEREAS, pursuant to Elections Code Section 10400, such election for cities and special districts may be either completely or partially consolidated; and

WHEREAS, pursuant to Elections Code Section 10403, whenever an election called by a district, city or other political subdivision for the submission of any question, proposition, or office to be filled is to be consolidated with a statewide election, and the question, proposition, or office to be filled is to appear upon the same ballot as that provided for that statewide election, the district, city or other political subdivision shall, at least 88 days prior to the date of the election, file with the board of supervisors, and a copy with the elections official, a resolution of its governing board requesting the consolidation, and setting forth the exact form of any question, proposition, or office to be voted upon at the election, as it is to appear on the ballot. Upon such request, the Board of Supervisors may order the consolidation; and

WHEREAS, the resolution requesting the consolidation shall be adopted and filed at the same time as the adoption of the ordinance or order calling the election; and

WHEREAS, various district, county, state and other political subdivision elections may be or have been called to be held on November 3, 2026;

NOW, THEREFORE, BE IT RESOLVED BY THE BOARD OF DIRECTORS OF THE SALTON COMMUNITY SERVICES DISTRICT AS FOLLOWS:

- I. Hereby order an election be called and consolidated with any and all elections on November 3, 2026 insofar as said elections are to be held in the same territory or in territory that is in part the same as the territory of the Salton Community Services District requests the Board of Supervisors of the County of Imperial to order such consolidation under Elections Code Section 10401 and 10403; and
- II. That said governing body hereby requests that the Board of Supervisors permit the Imperial County Elections Department to provide any and all services necessary for conducting the election and agrees to pay for said services; and
- III. The Imperial County Elections Department conduct the election for the following offices on November 3, 2026, ballot.
- IV. **SEATS OPEN:** 3 Directors At Large, **TERM OF OFFICE:** Four (4) Years Each;

PASSED, APPROVED AND ADOPTED BY the Board of Directors of the Salton Community Services District, Salton City, California, held on the 20th day of May, 2026, by the following vote:

	YES	NO
Michael Friese, President	_____	_____
Oscar Ramirez, Vice President	_____	_____
Manuel Ramos, Director	_____	_____
Lidia Sierra, Director	_____	_____
David Reagle, Director	_____	_____

Michael Friese, President of the Board of Directors

Attest:

Sonia Thania Garcia, Secretary to the Board of Directors



1209 VAN BUREN AVE.
POST OFFICE BOX 5268
SALTON CITY, CALIFORNIA 92275-5268
TELEPHONE: (760) 394-4446
scsd@saltoncsd.ca.gov

Field Foreman Omar Ruiz April 2026 SCSD

SCSD has continued with its normally scheduled services to stations and facilities

- Daily station hour readings.
- Collecting samples for Lab testing.
- Monitoring of station conditions.
- Collect data on pond reading.
- Test station alarm systems.
- Change the feeding pond accordingly.
- Upkeep of all three pond facilities

Throughout April, the team and I have replaced and or serviced various pieces of equipment to ensure smooth operations. Some items include upkeep on our AED equipment, service, coolant tank replacement, and battery replacement on F150, service and replacement of broken handwear on sewer jet, service on RAV 4,



April 20th.

While running stations, the team noticed an issue with station 8 not running as it should. After some troubleshooting, the team found that one of the capacitors was out of spec. After the replacement motor was back to normal operations.





1209 VAN BUREN AVE.
POST OFFICE BOX 5268
SALTON CITY, CALIFORNIA 92275-5268
TELEPHONE: (760) 394-4446
scsd@saltoncsd.ca.gov

Park Supervisors Report For April 2026

Salton City Park

- We continue to monitor homelessness and vandalism.
- Wash the floors with Simple Green, restock the restrooms with toilet paper
- New shade came in
- Installed secure covers on electrical outlets within the Activity Room to prevent unauthorized use and ensure public safety.

Desert Shores Park

- Washed the patio and sidewalk
- routine mowing of all turf areas
- Applied fertilizer on the brown spots on the soccer field
- Continue to install sprinkler system for dust control

Buildings

- Addressed an odor issue at the office buildings. A vent cleaner has been ordered to sanitize the ductwork.
- Change out a/c filters
- Clean all window blinds at the office
- Trimmed a tree at the old firefighter bldg. That fell on the fence
- Repaired the fence due to high winds



1209 Van Buren Avenue, Suite 1
POST OFFICE BOX 5268
SALTON CITY, CALIFORNIA 92275-5268
TELEPHONE: (760) 394-4446
FAX: (760) 394-4242
scsd@saltoncsd.ca.gov

Serving the West Shores of the Fabulous Salton Sea

General Managers Report

Emmanuel Ramos

April 2026

We participated in a meeting focused on the seating arrangements for Special Districts on the LAFCO Commission. Representing SCSD were President Fiese, Board Secretary Thania, and myself. The meeting was also attended by representatives from several other special districts, fostering a collaborative discussion on this important matter.

We have been proactively reaching out to various companies to undertake maintenance on the wells adjacent to the TRC ponds, as mandated by one of our board orders. While we have contacted numerous service providers, we have found that there are limited options available in the Salton City area.

We are actively collaborating with Bio-Alchemy to manage BOD levels. As we approach a year without receiving an NVO, we remain hopeful for progress in this area.

We have received a report concerning water surfacing from the Lansing Wastewater Treatment Facility. In response, Adrien Lopez from the Water Boards conducted a thorough investigation. His findings indicated that the ground was dry, with no visible signs of water surfacing in the affected area. Additionally, he requested photographs from the Salton Community Services District (SCSD) regarding the specified locations, which were promptly provided. The images demonstrated that the area showed no indications of surfacing water.



1209 VAN BUREN AVE.
POST OFFICE BOX 5268
SALTON CITY, CALIFORNIA 92275-5268
TELEPHONE: (760) 394-4446
scsd@saltoncsd.ca.gov

Wednesday, May 20, 2026

Finance Report

For the Month of April:

Revenue: \$ 408,538.67
GF: \$ 99,448.19
SM: \$ 309,090.45

Expense: \$ 178,111.50
GF: \$ 12,378.18
SM: \$ 165,733.32

- 15% decrease in expenses over March
- 48% under budget on expenses so far, this 25-26 fiscal year

- Continued work with the Punn Group and O'Connor & Company on Audits
 - Receiving FY 23 Audited Financials the beginning of next month.
 - FY 24 financials will be submitted to auditors beginning of next month

- Continued drafting of budget for FY 26-27,

- Continued work with Muniwater Worth on Prop 218 Sewer Database

- Continued Work on SC Park Grant

- Working on End of Fiscal Year filings to the state



Salton Community Services District

MEETING DATE: 05/20/2026 Item Number: 14. A

Staff Report: Resolution No. 2026-05-20-01

A RESOLUTION OF THE BOARD OF DIRECTORS OF THE SALTON COMMUNITY SERVICES DISTRICT APPROVING THE AGREEMENT REGARDING SPECIAL DISTRICT MEMBERSHIP IN AND FUNDING OF THE IMPERIAL COUNTY LOCAL AGENCY FORMATION COMMISSION

To: Board of Directors

From: District Administration

Date: May 12, 2026

Executive Summary

The Salton Community Services District (SCSD) is considering joining an agreement with other independent special districts in Imperial County. This agreement establishes a formal process for special districts to have representation on the Imperial County Local Agency Formation Commission (ICLAFCO) and sets an alternative funding method for the associated operational costs.

Background

Currently, ICLAFCO does not include members from independent special districts. Under California law, when special districts are granted representation on a commission, they are collectively responsible for providing one-third of the commission's operational costs.

The standard law requires these costs to be shared among all districts based on their revenues. However, the law also allows districts to approve an "alternative method" for sharing these expenses if a majority of the districts and population agree.

Key Terms of the Agreement

The proposed agreement introduces a specific funding arrangement primarily involving the Imperial Irrigation District (IID):

- **100% Funding by IID:** The IID agrees to pay **100%** of the special districts' share of ICLAFCO's net operating costs.
- **Condition for Funding:** This full funding is strictly conditioned on the selection of specific representatives to ICLAFCO:
 - **Seat One:** A member from a special district who is **not** on the IID Board.
 - **Seat Two:** A member who **is** on the IID Board and nominated by the IID.
 - **Alternate Member:** A member who **is** on the IID Board and nominated by the IID.
- **Contingency Plan:** If the selection committee chooses members who do not meet these IID requirements, the IID will only pay **50%** of the costs, and the remaining 50% will be shared among the other special districts.

Fiscal Impact

By entering this agreement, SCSD potentially avoids direct costs for ICLAFCO operations, as the IID has committed to covering the districts' entire one-third share, provided their representation conditions are met. If those conditions are not met, SCSD would be liable for its portion of the remaining 50% of the districts' share.

Recommendation

It is recommended that the Board of Directors adopt **Resolution No. 2026-05-20-01**. This resolution:

1. Authorizes the Board President to execute the agreement.
2. Directs the General Manager and legal counsel to take necessary steps to implement the terms.

RESOLUTION NO. 2026-05-20-01

**A RESOLUTION OF THE BOARD OF DIRECTORS OF THE SALTON
COMMUNITY SERVICES DISTRICT APPROVING THE AGREEMENT
REGARDING SPECIAL DISTRICT
MEMBERSHIP IN AND FUNDING OF THE IMPERIAL COUNTY
LOCAL AGENCY FORMATION COMMISSION**

WHEREAS, the Salton Community Services District is a Community Services District subject to California Government Code Section 6100 et. seq.

WHEREAS, the Salton Community Services District is an “independent special district” as defined in Government Code Section 56044 located within the geographical boundaries of the County of Imperial.

WHEREAS, a local agency formation commission (“LAFCO”) exists within the County of Imperial under the Cortese-Knox-Hertzberg Local Government Reorganization Act of 2000, Government Code section 56300, et seq (“ICLAFCO”).

WHEREAS, Government Code section 56332.5 provides for the process of including special district representation on ICLAFCO.

WHEREAS, the Salton Community Services District and other Special Districts in the County of Imperial wish to have representation on ICLAFCO.

WHEREAS, independent special district representation on ICLAFCO requires that they collectively pay one third of the of ICLAFCO’s operational expenses under Government Code Section 56381(b)(1)(A).

WHEREAS, Government Code 56381(b)(1)(E) permits the option of independent special districts’ share to be apportioned by an alternative method approved by a majority of the districts, representing a majority of the combined populations.

WHEREAS, the AGREEMENT REGARDING SPECIAL DISTRICT MEMBERSHIP IN AND FUNDING OF THE IMPERIAL COUNTY LOCAL AGENCY FORMATION COMMISSION (“Agreement”) has been circulated to the Salton Community Services District and other independent special districts to provide for an alternative method of apportionment of the Special Districts’ share of the net operating costs of ICLAFCO as provided therein.

WHEREAS, The Salton Community Services District Board of Directors desires to become a signatory to the Agreement.

NOW, THEREFORE, BE IT RESOLVED that the President of the Salton Community Services District is hereby authorized and directed to execute on behalf of the District the AGREEMENT REGARDING SPECIAL DISTRICT MEMBERSHIP IN AND FUNDING OF THE IMPERIAL COUNTY LOCAL AGENCY FORMATION COMMISSION, a copy of which is attached hereto as Exhibit “A” (“Agreement”) and incorporated herein by this

reference containing such non substantive changes as are approved by the President and the Salton Community District’s legal counsel; and

RESOLVED FURTHER that the General Manager, legal counsel and staff of the Salton Community Services District are hereby authorized and directed to take those actions and execute those documents as are reasonably needed to implement and carry out the terms of Agreement on behalf of the Salton Community Services District provided that Board approval shall be required for actions that are contemplated to be taken by the Board under the Agreement and applicable law and policy including, but not limited to, any amendment or termination of the Agreement.

PASSED AND ADOPTED by the Salton Community Services District at a regular meeting held on the 20th day of May 2026, by the following vote:

	YES	NO
Michael Friese, President	_____	_____
Oscar Ramirez, Vice President	_____	_____
Manuel H. Ramos, Director	_____	_____
Lidia Sierra, Director	_____	_____
David Reagle, Director	_____	_____

Michael Friese, President of the Board of Directors

ATTEST:

Sonia Thania Garcia, Secretary of the Board of Directors

EXHIBIT "A"

(ATTACH AGREEMENT REGARDING SPECIAL DISTRICT MEMBERSHIP IN AND
FUNDING OF THE IMPERIAL COUNTY LOCAL AGENCY FORMATION COMMISSION)

**AGREEMENT REGARDING SPECIAL DISTRICT
MEMBERSHIP IN AND FUNDING OF THE IMPERIAL COUNTY
LOCAL AGENCY FORMATION COMMISSION**

This Agreement (“Agreement”) is entered into by and between the following independent special districts located within the geographical boundaries of the County of Imperial:

- Bard Resource Conservation District (“BRCD”)
- Bard Water District (“Bard”)
- Bombay Beach Community Service District (“Bombay Beach”)
- Central Valley Cemetery District (“CVCD”)
- Heber Public Utility District (“HPUD”)
- Imperial Irrigation District (“IID”)
- Imperial Valley Healthcare District (“IVHD”)
- Palo Verde County Water District (“Palo Verde”)
- Riverview Cemetery District (“RCD”)
- Salton Community Service District (“SCSD”)
- Seeley County Water District (“Seeley”)
- Winterhaven County Water District (“Winterhaven”)

(Collectively, the “Special Districts”)

The Special Districts may be collectively referred to herein as the “Parties.”

RECITALS

The Parties enter into this Agreement in reference to the following facts:

- A. In each county in California, there exists a local agency formation commission, formed pursuant to the Cortese-Knox-Hertzberg Local Government Reorganization Act of 2000, Government Code section 56300, *et seq.*
- B. Unless specifically provided for otherwise by state law, Government Code section 56325 provides that local agency formation commissions are to be comprised of seven (7) members:
 - a. Two (2) appointed by the board of supervisors from their own membership.
 - b. Two (2) appointed by the cities in the county, each of whom shall be a mayor or council member, appointed by the city selection committee

- c. Two (2) presiding officers or members of legislative bodies of independent special districts appointed by the independent special district selection committee
 - d. One (1) representing the general public appointed by the other members of the commission.
- C. Currently, the local agency formation commission for Imperial County ("ICLAFCO") does not include members who are presiding officers or members of legislative bodies of independent special districts appointed by the independent special district selection committee.
 - D. In instances in which a local agency formation commission does not have representation from independent special districts prior to 2001, as is the case with ICLAFCO, Government Code section 56332.5 provides for the process of including special districts. Special Districts seek to implement the provisions of the Government Code and have representation on ICLAFCO.
 - E. Government Code section 56381(b)(1)(A) provides that when a local agency formation commission has independent special district representation, the county, cities, and special districts shall each provide a one-third share of the commission's operational costs.
 - F. Government Code section 56381(b)(1)(C) provides generally that the independent special districts' share shall be apportioned in proportion to each district's total revenues as a percentage of the combined total district revenues within a county. The Parties acknowledge the application of Government Code Section 56381(b)(1)(D) with respect to IVHD.
 - G. Government Code section 56381(b)(1)(E) generally provides that the independent special districts' share of the commission's net operational costs may be apportioned by an alternative method approved by a majority of the districts, representing a majority of the combined populations, but that in no event shall an individual district's apportionment exceed the amount that would be calculated pursuant to subparagraphs (C) and (D), or in excess of 50 percent of the total independent special districts' share, without the consent of that district.
 - H. The Special Districts desire to enter into this Agreement to provide for an alternative method of apportionment of the Special Districts' share of the net operating costs of ICLAFCO.

AGREEMENT

Upon this mutual understanding, the Parties agree as follows:

1. OPERATING EXPENSES - ALTERNATIVE APPORTIONMENT.

- 1.1. The Parties agree to the following alternative method of apportionment of the independent special districts' share of the net operating costs of ICLAFCO:
- Upon the Special Districts being represented on ICLAFCO, IID shall pay 100% of the net operating costs of ICLAFCO attributable to the Special Districts on the express condition that the terms of Paragraphs 2.1.2 and 2.1.3 are satisfied.
- 1.2. IID consents to an apportionment greater than fifty percent (50%) of the net operating costs as established by Government Code section 56381(b)(1)(F) on the express condition that the terms of Paragraphs 2.1.2 and 2.1.3 are satisfied.
- 1.3. In the event the independent special district selection committee selects members inconsistent with the terms identified in Paragraphs 2.1.2 and/or 2.1.3, all Special Districts shall be liable for their portion of the net operating costs as calculated pursuant to Government Code section 56381(b)(1)(C). The Parties acknowledge provisions applicable to IVHD as outlined in Recital F. However, the failure of IID to nominate and select a member for the independent special district selection committee's consideration shall not constitute a violation for purposes of this section.

2. SPECIAL DISTRICT REPRESENTATION.

- 2.1. The Special Districts are entitled to select two members of the board of ICLAFCO, appointed by the independent special district selection committee (the committee of presiding officers or board appointee of the legislative bodies of independent special districts, convened pursuant to Government Code section 56332(b)). To obtain IID's consent to an apportionment in excess of 50% identified in Paragraph 1.2 and IID's agreement to pay 100% of the net operating costs of ICLAFCO attributable to the Special Districts identified in Paragraph 1.1, the Parties agree that the independent special district selection committee select two regular members and one alternate member in the following manner:
- 2.1.1. Seat One. The first Special District member, who is not a member of the IID Board of Directors, in accordance with Government Code sections 56325 and 56332.
- 2.1.2. Seat Two. The second Special District member, who is a member of the IID Board of Directors and nominated by the IID Board of Directors, in accordance with Government Code sections 56325 and 56332. Failure of IID to nominate a member for the independent

special district selection committee's consideration shall not constitute a violation for purposes of Section 1.3.

2.1.3. Alternate Member. The alternate Special District member, who is a member of the IID Board of Directors and nominated by the IID Board of Directors, in accordance with Government Code sections 56325 and 56332. Failure of IID to nominate a member for the independent special district selection committee's consideration shall not constitute a violation for purposes of Section 1.3.

3. This Agreement shall serve as the "alternative method" of apportionment and shall become binding on all Parties once approved by a majority vote of the Special Districts representing a majority of the combined total population of independent special districts in the county.
4. If the independent special district selection committee does not elect members who are nominated by the IID Board to both a Seat Two member and alternate member positions, the cost arrangement will be reflect that IID pay 50% of the total cost and the other special districts will pay 50%. Subsequently, if at any time, the special district selection committee elects members who are nominated by the IID Board to both a member and alternate member positions, IID will at all such times pay 100% of the costs.
5. The parties agree that ICLAFCO and all Parties retain any and all of their rights, powers, and remedies, and no remedy shall be exclusive of any of the others, or of any other legal or equitable remedy which any party might otherwise have in the event of breach or default of this Agreement. The exercise of any right or remedy by a party shall not impair its right to any other right or remedy under this Agreement or otherwise available at law or in equity. Any disputes arising under this Agreement shall be resolved in the Superior Court of the State of California, County of Imperial.
6. The parties each represent and warrant that the signatories to this Agreement have the authority to execute this Agreement on behalf of their respective agency.
7. This Agreement shall not be modified or amended except in a writing signed by the parties.
8. This Agreement may be executed in counterparts each of which shall be deemed to be an original and all of which when taken together shall be deemed to be but one agreement.

In witness whereof, these Parties have executed this Agreement effective on the date set forth below.

Bard Resource Conservation District

By: _____
Signature
Printed Name: _____
Title: _____

Date Signed: _____

Bard Water District

By: _____
Signature
Printed Name: _____
Title: _____

Date Signed: _____

Bombay Beach Community Service District

By: _____
Signature
Printed Name: _____
Title: _____

Date Signed: _____

Central Valley Cemetery District

By: _____
Signature
Printed Name: _____
Title: _____

Date Signed: _____

Heber Public Utility District

By: _____
Signature
Printed Name: _____

Date Signed: _____

Imperial Irrigation District

By: _____
Signature
Printed Name: _____
Title: _____

Date Signed: _____

Imperial Valley Healthcare District

By: _____
Signature
Printed Name: _____
Title: _____

Date Signed: _____

Palo Verde County Water District

By: _____
Signature
Printed Name: _____
Title: _____

Date Signed: _____

Riverview Cemetery District

By: _____
Signature
Printed Name: _____
Title: _____

Date Signed: _____

Salton Community Service District

By: _____
Signature
Printed Name: _____
Title: _____

Date Signed: _____

Seeley County Water District

By: _____
Signature
Printed Name: _____
Title: _____

Date Signed: _____

Winterhaven County Water District

By: _____
Signature
Printed Name: _____
Title: _____

Date Signed: _____

**SALTON COMMUNITY SERVICES DISTRICT
1209 VAN BUREN AVENUE
SALTON CITY, CA 92274**

Phone: (760) 394-4446

PROJECT MANUAL

SALTON CITY PARK RESTROOM IMPROVEMENTS



Pre-Bid Conference Date (Optional): **June 2, 2026**

Bid Opening Date: **June 22, 2026, at 2:00 PM**

SPECIAL NOTICE

Pursuant to the requirements of Senate Bill 854 and California Labor Code section 1725.5, all contractors and subcontractors that wish to engage in public work through a public works contract must first register with the Department of Industrial Relation and pay all applicable fees.

Beginning March 1, 2015, no contractor or subcontractor may be listed on a bid proposal for a public works project unless registered with the Department of Industrial Relations, pursuant to Labor Code section 1725.5 (with limited exceptions from this requirement for bid purposes only under Labor Code section 1771.1(a)).

Beginning April 1, 2015, no contractor or subcontractor may be awarded a contract for public work on a public works project unless registered with the Department of Industrial Relations, pursuant to Labor Code section 1725.5.

This Project is subject to compliance monitoring and enforcement by the Department of Industrial Relations.

For more information concerning Senate Bill 854 compliance, please visit:
<http://www.dir.ca.gov/Public-Works/SB854.html>,

PUBLIC WORKS REFORMS (SB 854) FACT SHEET

Public works reforms (SB 854) were signed into law on June 20, 2014. The reforms made several significant changes to the administration and enforcement of prevailing wage requirements by the Department of Industrial Relations (DIR). Among other things, SB 854 established a public works contractor registration program to replace prior Compliance Monitoring Unit (CMU) and Labor Compliance Program (LCP) requirements for bond funded and other specified public works projects. The fees collected through the program established by SB 854 are used to fund DIR's public works activities.

Essentials of public works contractor registration program:

- Contractors are subject to a registration and annual renewal fee set at \$400. This fee is non-refundable and applies to all contractors and subcontractors who intend to bid or perform work on public works projects (as defined under the Labor Code).
- Contractors apply and pay the fee online and must meet minimum qualifications to be registered as eligible to bid and work on public works projects:
 - Must have workers' compensation coverage for any employees and only use subcontractors who are registered public works contractors.
 - Must have Contractors State License Board license if applicable to trade.
 - Must not have any delinquent unpaid wage or penalty assessments owed to any employee or enforcement agency.
 - Must not be under federal or state debarment. ○ Must not be in prior violation of this registration requirement once it becomes effective. However, for the first violation in a 12-month period, a contractor may still qualify for registration by paying an additional penalty.
- The registration fee is not related to any project. It is more like a license that enables the registrant to bid on and perform public works.
- DIR provides a searchable database of registered contractors and subcontractors on its website, so that awarding bodies and contractors can comply with the requirement to only use registered contractors and subcontractors.
- Various protections are built in so that
 - A contractor won't be in violation for working on a private job that is later determined to be public work;
 - The inadvertent listing of an unregistered subcontractor on a bid doesn't necessarily invalidate that bid;
 - A contract with an unregistered contractor or subcontractor is subject to cancellation but is not void as to past work;
 - An unregistered contractor or subcontractor can be replaced with one who is registered;
 - A contractor whose registration lapses will have a 90-day grace period within which to pay a late fee and renew.
- Contractors and subcontractors register online. The preferred method of payment is by credit card.

- The requirement to list only registered contractors and subcontractors on bids became effective on March 1, 2015. The requirement to only use registered contractors and subcontractors on public works projects applies to all projects awarded on or after April 1, 2015.

Essentials of Public Works Enforcement Fund:

All contractor registration fees go into the State Public Works Enforcement Fund and are used to fund the following items:

- Administration of contractor registration requirement;
- All DIR costs for administering and enforcing public works laws;
- Labor Commissioner's enforcement of other Labor Code violations on monitored public works projects.

DIR no longer charges awarding bodies for prevailing wage compliance monitoring and enforcement on legacy CMU projects.

Related changes in DIR's administration and enforcement of public works requirements:

- Requirements to use CMU or specified alternative (labor compliance program or project labor agreement) for state bond-funded and other specified projects were eliminated and replaced by requirements that apply to *all* public works projects (as defined under the Labor Code).
- Awarding bodies are required to submit PWC-100 (contract award notice) for all public works projects.
- Contractors and subcontractors on *all* public works projects are required to submit certified payroll records (CPRs) to the Labor Commissioner unless excused from this requirement.
 - CPRs are furnished to the Labor Commissioner online ○ This requirement phases in as follows:
 - Applied to public works projects that had been under CMU monitoring;
 - Applies to any new projects awarded on or after April 1, 2015;
 - May apply to other projects as determined by Labor Commissioner;
 - Applies to *all* public works projects, (except those listed under Exemptions just below), on and after January 1, 2016. ○ Exemptions: As of April 1, 2015, and even after January, 1, 2016, the following projects are exempt from the requirement to have contractors and subcontractors furnish certified payroll records (CPRs) to the Labor Commissioner:

Small Project Exemption

Contractors who work exclusively on small public works projects are not required to register as a public works contractor or file electronic certified payroll reports for those projects. Contractors are still required to maintain certified payroll records on a continuous basis, and provide them to the Labor Commissioner's Office upon request. Additionally, awarding agencies are not required to submit the notice of contract award through DIR's

PWC-100 system on projects that fall within the small project exemption. The small project exemption applies for all public works projects that do not exceed:

- \$25,000 for new construction, alteration, installation, demolition or repair
- \$15,000 for maintenance

Any projects monitored and enforced by the following legacy LCPs:

- California Department of Transportation (Caltrans)
- City of Los Angeles
- Los Angeles Unified School District
- County of Sacramento

Projects covered by qualifying project labor agreements, at the Labor Commissioner's discretion.

- Requirements for awarding bodies to adopt and enforce a DIR-approved LCP are now limited to: (1) ongoing public works projects awarded prior to January 1, 2012, that were under a pre-existing LCP requirement (see the four legacy LCPs listed above) and (2) projects funded in whole or in part by Proposition 84.

June 2017

**SALTON COMMUNITY SERVICES DISTRICT
SALTON CITY PARK
RESTROOM IMPROVEMENTS
DISTRICT PROJECT NO. SCP-1**

TABLE OF CONTENTS

NOTICE TO CONTRACTOR CALLING FOR BIDS.....	1
INFORMATION FOR BIDDERS.....	6
BID FORM.....	11
NON-COLLUSION AFFIDAVIT TO BE EXECUTED BY BIDDER AND SUBMITTED WITH BID	15
DESIGNATION OF SUBCONTRACTORS	16
PUBLIC CONTRACT CODE SECTION 10162 QUESTIONNAIRE.....	19
CONTRACTOR'S CERTIFICATE REGARDING WORKERS COMPENSATION	21
BID BOND	22
PERFORMANCE BOND	24
PAYMENT BOND	26
CONTENTS OF GENERAL CONDITIONS	28
GENERAL CONDITIONS.....	31
EXHIBIT A - GENERAL SPECIFICATIONS	
EXHIBIT B – SAMPLE AGREEMENT FOR SERVICES	
EXHIBIT C – ARCHITECTURAL PLAN SET	

NOTICE TO CONTRACTOR CALLING FOR BIDS

NOTICE IS HEREBY GIVEN that the Salton Community Services District, acting by and through its Board of Directors (hereinafter referred to as "District"), will receive up to, but not later than **2:00 PM** on **June 22, 2026** sealed bids for the award of a contract for the proposed project:

**SALTON COMMUNITY SERVICES DISTRICT
SALTON CITY PARK
RESTROOM IMPROVEMENTS**

DISTRICT PROJECT NO. SCP-1

The Contractor shall possess a California Contractor's **B** License at the time this contract is awarded.

Estimated Cost. The estimated construction cost is **\$139,125**.

Bids shall be received at the Salton Community Services District offices located at 1209 Van Buren Avenue, Salton City, CA 92274, and shall be opened publicly and read aloud at the above stated time and place.

Each bid package must conform and be responsive to the contract documents, bid sets are available starting on **May 21, 2026**, via PlanWell Plan Room <https://www.planitplanroom.com/>

Only those firms who have purchased the bid documents will be mailed any addendums that may be issued for this project prior to the bid opening date.

Each bid shall be accompanied by the bid security referred to in the contract documents and the list of proposed subcontractors in the form of a certified or cashier check or a bid bond for ten percent (10%) of the maximum bid amount being proposed.

In contracts involving expenditure in excess of ten thousand dollars (\$10,000), the successful bidder shall file a payment bond in a penal sum at least equal to the full contract value as awarded. The bond shall be approved by District and shall be in the form set forth in the contract documents. The successful bidder shall also file a performance bond in a penal sum at least equal to the full contract value as awarded.

A performance and payment bond must be filed for contracts involving expenditure in excess of twenty-five thousand dollars (\$25,000), and may be required for contracts involving smaller expenditures at the option of District.

A Contractor's and Subcontractor's Pre-Bid Conference will be held on the following date: **June 2, 2026**, at **9:00 AM** at the project site 2208-2210 Iridescent Avenue, Thermal, CA 92274.

Contact Person: Kristin Hermann, Hermann Design Group

Telephone: (760)777-9131 x102 / Email: kristin@hdg-inc.com

Attendance at the Pre-Bid Conference and Facility Walkthrough is **RECOMMENDED**.

Before submitting a bid, ALL BIDDERS are required to examine the project site and fully inform themselves as to all existing site conditions and limitations. The bid proposal shall include the cost of all items necessary for the construction of the Project. Bidder shall not receive any additional compensation for costs resulting from conditions that Bidder could have discovered with due diligence prior to submitting a bid.

Any potential bidder whom has been deemed ineligible to perform work on public works projects pursuant to Labor Code Sections 1777.1 or 1777.7 shall be prohibited from bidding on, being awarded a contract for, or performing work as a subcontractor on this project, or any other public works project within the state of California.

District reserves the right to reject any or all bids or to waive any irregularities or informalities in any bids or in the bidding.

All information required by the bid forms must be completely and accurately provided. Numbers shall be stated in both words and figures where so indicated in the bid forms; conflicts between a number stated in words and in figures are governed by the words. Partially completed Bid Proposals, including bid forms with items left blank, or Bid Proposals submitted on other than the bid forms included herein are non-responsive and will be rejected. Bid Proposals not conforming to these instructions for bidders and the Notice to Contractors Calling for Bids may be deemed nonresponsive and rejected.

Pursuant to Section 20103.8 of the Public Contract Code: A local agency may require a bid for a public works contract to include prices for items that may be added to, or deducted from, the scope of work in the contract for which the bid is being submitted. Whenever additive or deductive items are included in a bid, the bid solicitation shall specify which one of the following methods will be used to determine the lowest bid. In the absence of a specification, only the method provided by subdivision (a) will be used:

- (a) The lowest bid shall be the lowest bid price on the base contract without consideration of the prices on the additive or deductive items.

A responsible bidder who submitted the lowest bid as determined by this section shall be awarded the contract, if it is awarded. This section does not preclude the local agency from adding to or deducting from the contract any of the additive or deductive items after the lowest responsible bidder has been determined.

**ENGINEER'S OPINION OF PROBABLE QUANTITY
BASE BID**

AL = Allowance CF = Cubic Feet CY = Cubic Yard EA = Each LB = Pounds
 LF = Linear Foot LS = Lump Sump SF = Square Feet TON = (2,000 lbs)

ITEM No.	ITEM DESCRIPTION	UNIT	ESTIMATED QUANTITY
1.	General Requirements: Mobilization/Demobilization, temporary facilities, construction sign, insurance, bonds, taxes, fees, permits and similar expenses	LS	1
2.	Selective Demolition	LS	1
3.	Concrete	LS	1
4.	Metal Fabrication	LS	1
5.	Wood, Plastics and Composites	LS	1
6.	Openings	LS	1
7.	Finishes	LS	1
8.	Specialties	LS	1
9.	Plumbing	LS	1
10.	Mechanical	LS	1
11.	Electrical	LS	1

Nothing in this section shall preclude the prequalification of subcontractors.

District hereby affirms and notifies all bidders that it will affirmatively ensure that in any contract entered into pursuant to this advertisement, disadvantaged business enterprises will be afforded full opportunity to submit bids in response to this invitation and will not be discriminated on the grounds of race, sex, color, or national origin in consideration for an award.

Pursuant to section 1773 of the Labor Code, the general prevailing rate of wages in the County in which the work is to be done has been determined by the Director of the California Department of Industrial Relations.

The Director of Industrial Relations has determined the general prevailing rate of per diem wages in the locality in which this work is to be performed for each craft or type of worker needed to execute the contract which will be awarded to the successful bidder.

Use the following internet access URL:
[Director's General Prevailing Wage Determinations \(ca.gov\)](#)

It shall be mandatory upon the Contractor to whom the contract is awarded, and upon any subcontractor under it, to pay not less than the said specified rates to all workers employed by them in the execution of the contract. No bidder may withdraw their bid for a period of ninety (90) days after the date set for the opening of bids.

Bidders are advised that they may elect to substitute securities for any retention of funds by the District to ensure performance under the Contract. At the request and expense of

Bidder, securities equivalent to the amount retained shall be deposited with the District, or with a state or federally chartered bank in this state as the escrow agent, who shall then return the securities to Bidder once the Project has been completed.

Alternatively, the Bidder may request, and the District shall make payment of retentions earned directly to the escrow agent at the expense of the Bidder. The Bidder, at its sole cost and expense, may direct the investment of the payments into securities, and the Bidder shall receive the interest earned on the investments. Once the Project has been completed, the Bidder shall receive from the escrow agent all securities, interest and payments received by the escrow agent from the District.

Securities eligible for investment include those listed in Cal Gov Code § 16430, bank or savings and loan certificates of deposit, interest-bearing demand deposit accounts, standby letters of credit, or any other security mutually agreed to by the District and the Bidder. The Bidder shall be the beneficial owner of any securities substituted for retained funds and shall receive any interest thereon.

Substitution of securities shall be conducted through an Escrow Agreement substantially similar to that found in Cal Pub Contract Code § 22300(f).

PLEASE NOTE: Substitution of securities is prohibited where funding for the Project, in whole or in part, will be provided by the Farmers Home Administration of the United States Department of Agriculture pursuant to the Consolidated Farm and Rural Development Act (7 U.S.C. Sec 1921 et seq.) or where otherwise disallowed by federal law.

Emmanuel Ramos
General Manager

Date

VICINITY MAP

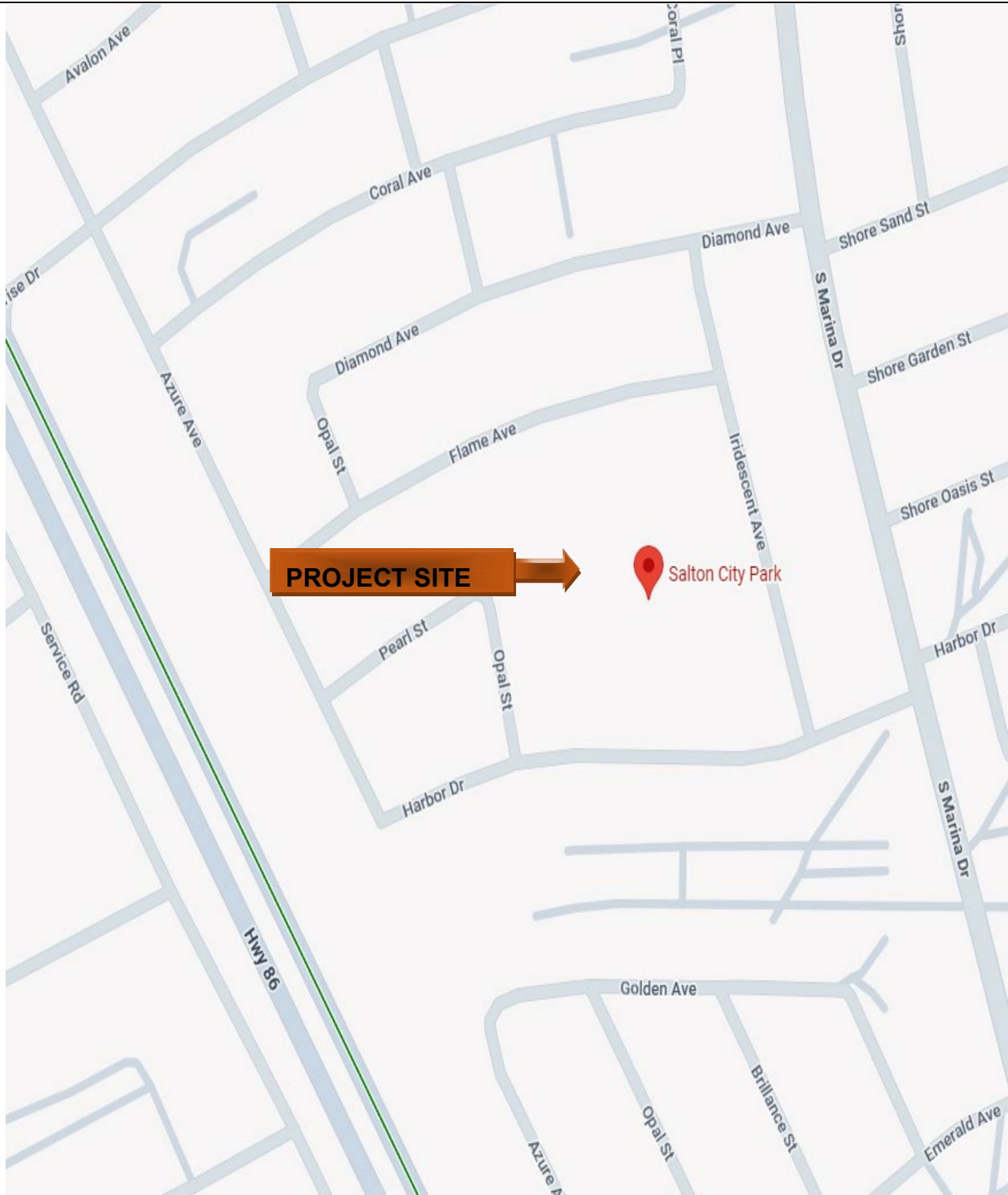

SALTON COMMUNITY
SERVICES DISTRICT
Salton City, CA

SALTON CITY PARK
RESTROOM IMPROVEMENTS
District Project No. SCP-1

INFORMATION FOR BIDDERS

1. Preparation of Bid Form. District invites bids on the form attached to be submitted at such time and place as is stated in the form *Notice to Contractors Calling for Bids*. All blanks in the bid form must be appropriately completed, and all prices must be stated in both words and figures. All bids must be submitted in sealed envelopes bearing on the outside the name of the bidder, the bidder's address, and the name of the project for which the bid is submitted. It is the sole responsibility of the bidder to see that the bid is received by District prior to the date and time specified for opening bids. Any bid received after the scheduled closing time for receipt of bids will be returned to the bidder unopened.
2. Bid Security. Each bid shall be accompanied by a certified or cashier's check payable to District or a satisfactory bid bond in favor of District executed by the bidder as principal and a satisfactory surety company as surety, in an amount not less than ten percent (10%) of the maximum amount of the bid. The check or bid bond shall be given as guarantee that the bidder shall execute the contract if it be awarded to it in conformity with the contract documents and shall provide the surety bond or bonds as specified therein within ten (10) days after notification of the award of the contract to the bidder.
3. Signature. The bid must be signed in the name of the bidder and must bear the signature in longhand of the person or persons duly authorized to sign the bid.
4. Modifications. Changes in or additions to the bid form, recapitulations of the work bid upon, alternative proposals, or any other modification of the bid form which is not specifically called for in the contract documents may result in District's rejection of the bid as not being responsive to the invitation to bid. No oral or telephonic modification may be considered.

Any proposed modifications of a bidder's bid must be in writing and received by District prior to the date and time specified for opening bids.

5. Erasures. The bid submitted must not contain any erasures, interlineations, or other corrections unless each such correction is suitably authenticated by affixing in the margin immediately opposite the correction and the surname, or surnames of the person or persons signing the bid.
6. Examination of Site and Contract Documents. Each bidder shall visit the site of the proposed work and fully acquaint itself with the conditions relating to the construction and labor so that it may fully understand the facilities, difficulties and restrictions attending the execution of the work under the contract. Bidders shall thoroughly examine and be familiar with the drawings and specifications. The failure or omission of any bidder to receive or examine any contract documents, form, instrument, addendum or other document, or to visit the site and acquaint itself with conditions there existing, shall in no way relieve any bidder from obligations with respect to its bid or to the contract. The submission of a bid shall be taken as *prima facie* evidence of compliance with this section.

7. Withdrawal of Bids. Any bidder may withdraw its bid either personally, by written request, or by telegraphic request confirmed in the manner specified above at any time prior to the scheduled closing time for receipt of bids.
8. Relief from Mistake in Bid. The attention of bidders is called to Public Contracts Code sections 5100 to 5104, particularly the requirements of section 5103 which requires that grounds for relief from a mistaken bid require written notice to the public entity within five (5) working days after the opening of the bids of mistake and such notice shall detail how the mistake occurred. Please note that a bidder shall not be relieved of its bid unless the elements of Public Contract Code section 5103 are met and the written consent of District is obtained and/or by order of a court of competent jurisdiction.
9. Agreements and Bonds. The agreement form which the successful bidder, as Contractor, will be required to execute, and the forms and amounts of the surety bonds which it will be required to furnish at the time of execution of the agreements, are included in the contract documents and should be carefully examined by the bidder. The required number of executed copies of the *Agreement*, the *Performance Bond*, and the *Payment Bond* for District Projects is as specified in the *Special Conditions*.
10. Interpretation of Plans and Documents. If any person contemplating submitting a bid for the proposed contract is in doubt as to the true meaning of any part of the drawings, specifications or other contract documents, or finds discrepancies in or omissions from the drawings and specifications, he or she shall submit to District a written request via email for an interpretation or correction thereof no less than ten (10) days prior to the bid opening. The person submitting the request will be responsible for its prompt delivery. Any interpretations or correction of the contract documents will be made only by addendum duly issued, and a copy of such addendum will be emailed to each person receiving a set of the contract documents. No oral interpretation of any provision in the contract documents will be made to any bidder. The interpretation of Plans and documents upon bid award shall be addressed in accordance with Article 2 of the "General Conditions."
11. Bidders Interested in More Than One Bid. No person, firm, or corporation shall be allowed to make, or file, or be interested in more than one bid for the same work unless alternate bids are specifically called for. A person, firm, or corporation that has submitted a sub-proposal to a bidder, or that has quoted prices of materials to a bidder, is not thereby disqualified from submitting a sub-proposal or quoting prices to other bidders or make a prime proposal.
12. Award of Contract. District reserves the right to reject any or all bids, or to waive any irregularities or informalities in any bids or in the bidding. The award of the contract, if made by District, will be to the lowest responsible bidder therefore. Award of the contract may be on **August 7, 2026** (tentative), and an Agreement shall be presented to the successful bidder at that time. Successful bidder shall then have ten (10) days to execute the Agreement and provide all payment and performance bonds required for this project. Please note that a posted tabulation may be a preliminary tabulation which has not been reviewed for responsiveness and responsibility. It is possible that the lowest bidder will not be awarded the contract because of non-responsiveness or non-responsibility.

13. Alternates. If alternate bids are called for, the contract may be awarded at the election of the governing board to the lowest responsible bidder on the base bid, or on the base bid and any alternate or combination of alternates.
14. Bidder Contact Information. The bidder shall submit complete name, address and phone listings, (including fax), and contact person at bidder's company, provide a complete list of all personnel, subcontractors, and other agencies that will be assigned to this project and the responsibility that each will have.
15. Listing Subcontractors. Each bidder shall submit with its sealed bid a list of the proposed subcontractors on this project as required by the Subletting and Subcontracting Fair Practices Act (Pub. Cont. Code, § 4100, et seq.). Forms for this purpose are furnished with the contract documents.
16. Workers Compensation and Prevailing Wage Compliance.
 - 16.1. Workers Compensation. In accordance with the provisions of Labor Code section 3700 *et. seq.* Contractor shall secure the payment of compensation to its employees. Contractor shall sign and file with District the following certificates prior to performing the work under this contract: "I am aware of the provisions of section 3700 of Labor Code which require every employer to be insured against liability for workers compensation or to undertake self-insurance in accordance with the provisions of that code, and I will comply with such provisions before commencing the performance of the work of this contract." The form of such certificate is included as a part of the contract documents.
 - 16.2. Prevailing Wage Compliance. Contractor and its subcontractors shall pay all workers employed on the Project the rates determined by the Director of the California Department of Industrial Relations (DIR). Copies of the State prevailing rate of per diem wages are on file with the Department of Industrial Relations, Division of Apprenticeship Standards, 445 Golden Gate Avenue, San Francisco, California, and at District's Department of Public Works, and are available to Contractor and any other interested party upon request. Contractor shall post the prevailing rate of per diem wages to be posted at the Project site.
 - 16.3. For those Projects subject to Department of Industrial Relations (DIR) Monitoring and Enforcement, be advised that the Contractor is responsible for submitting certified payroll records directly to the State Compliance Monitoring Unit (CMU). CMU is a new component within the State Division of Labor Standards Enforcement (DLSE) that was created to monitor and enforce prevailing wage requirements on public works projects that receive state bond funding and on other projects that are legally required to use the CMU. The CMU began operations on January 1, 2012, following the recent adoption of AB 436 and approval of revisions to program regulations. By actively monitoring compliance on an ongoing basis while work is being performed, the CMU will play a special role in ensuring that public works construction workers are promptly paid the proper prevailing wage rates and in helping maintain a level playing field for contractors who comply with the law.

Effective Date and Applicability: The laws and regulations that govern the new program are effective January 1, 2012. Only projects for which the public works contract is awarded on or after January 1, 2012 are subject to the CMU requirements. For further information concerning compliance monitoring please visit the website located at: <https://www.dir.ca.gov/PublicWorks/publicworks.html>.

17. Substitution of Security. Contractors may substitute securities in place of retained funds withheld by District in accordance with the provisions of Cal. Pub. Contract Code Section 22300.

18. Contractor's Pre-Bid Conference.

18.1. A Non-Mandatory Pre-Bid Conference will be held on the following date:

June 2, 2026 at 9:00 AM at the project site 2208-2210 Iridescent Drive, Thermal, CA 92274.

**SALTON COMMUNITY SERVICES DISTRICT
SALTON CITY PARK
RESTROOM IMPROVEMENTS
DISTRICT PROJECT NO. SCP-1**

Contact Person: Kristin Hermann, Hermann Design Group
Telephone: (760)777-9131 x102 / Email: kristin@hdg-inc.com

18.2. Attendance at the Pre-Bid Conference and Walkthrough is **RECOMMENDED.**

18.3. Before submitting a bid, ALL BIDDERS are required to examine the project site and fully inform themselves as to all existing site conditions and limitations. The bid proposal shall include the cost of all items necessary for the construction of the Project. Bidder shall not receive any additional compensation for costs resulting from conditions that Bidder could have discovered with due diligence prior to submitting a bid.

18.4. In accordance with Paragraph 10 of the Information for Bidders, any questions must be in writing via email and received by District from General Contractor or subcontractor submitting a Bid on or before **June 12, 2026, at 4:00 PM.** Questions shall be emailed to kristin@hdg-inc.com.

19. Calendar of Events.

1.	Bid packages available via PlanWell	<u>May 21, 2026</u>
2.	Pre-Bid Conference and Facility Walkthrough	<u>June 2, 2026 9:00am</u>
3.	Document Questions, and Substitution Requests. <u>Please be advised that Substitution Requests submitted after the due date may render this bid unresponsive.</u>	<u>June 12, 2026 by 4:00pm</u>
4.	<p>Bid package, inclusive of completed bid forms, and bid bond required to be submitted hereunder must be received by District on or before at:</p> <p>Salton Community Services District 1209 Van Buren Avenue Salton City, CA 9227 Phone: (760) 394-4446</p>	<u>June 22, 2026 at 2:00pm</u>
5.	Bid Opening	<u>June 22, 2026 at 2:00pm</u>
6.	Board review and consideration of award on approximately	<u>July 23, 2026 (Tentative)</u>
7.	Execution of Contract	<u>August 7, 2026 (Tentative)</u>
8.	Commencement of construction on or before	<u>August 24, 2026 (Tentative)</u>
9.	Completion of construction on	<u>November 23, 2026 (Tentative)</u>

BID FORM

TO: Board of Directors - Salton Community Services District

1. Pursuant to and in compliance with your *Notice to Contractors Calling for Bids* and the other documents relating thereto, the undersigned bidder, having familiarized itself with the terms of the contract, the local conditions affecting the performance of the contract, and the cost of the work at the place where the work is to be done, and with the drawings and specifications and other contract documents, hereby proposes and agrees to perform, within the time stipulated by the contract, including all of its component parts and everything required to be performed, and to provide and furnish any and all of the labor, materials, tools, expendable equipment and all utility and transportation services necessary to perform the contract and complete it in a workmanlike manner, all of the work required in connection with the **Salton Community Services District, SALTON CITY PARK – RESTROOM IMPROVEMENTS, District Project No. SCP-1:**

All in strict conformity with the drawings and specifications and other contract documents, including addenda nos., _____, _____, _____, and _____, for the total sum of _____ Dollars (\$_____), hereinafter called the *Base Bid Price*.

Warning - If an addendum or addenda have been issued by the Department and not noted above as being received by the bidder, this proposal may be rejected. District reserves the right to make award or any combination of base bid process plus deductive bid items as District determines to be in its best interest.

AL = Allowance CF = Cubic Feet CY = Cubic Yard EA = Each LB = Pounds
 LF = Linear Foot LS = Lump Sum SF = Square Feet TON = (2,000 lbs)

ITEM No.	ITEM DESCRIPTION	UNIT	EST. QTY	UNIT PRICE	TOTAL
1.	General Requirements: Mobilization/Demobilization, temporary facilities, construction sign, insurance, bonds, taxes, fees, permits and similar expenses	LS	1		
2.	Selective Demolition	LS	1		
3.	Concrete	LS	1		
4.	Metal Fabrication	LS	1		
5.	Wood, Plastics and Composites	LS	1		
6.	Openings	LS	1		
7.	Finishes	LS	1		
8.	Specialties	LS	1		
9.	Plumbing	LS	1		
10.	Mechanical	LS	1		
11.	Electrical	LS	1		

TOTAL BASE BID: _____

Note: The amount entered as the "Total Base Bid" should be identical to the Base Bid amount entered in Section 1 of the Bid Proposal form.

Warning - If an addendum or addenda have been issued by the Department and not noted above as being received by the bidder, this proposal may be rejected.

District reserves the right to make award or any combination of base bid process plus deductive bid items as District determines to be in its best interest.

2. It is understood that District reserves the right to reject this bid and that this bid shall remain open and not be withdrawn for the period specified in the Notice to Contractors Calling for Bids.
3. The required bid security is hereto attached.
4. The required list of proposed subcontractors is attached hereto.
5. It is understood and agreed that if written notice of the acceptance of this bid is mailed, telegraphed, or delivered to the undersigned after the opening of the bid, and within the time this bid is required to remain open, or at any time thereafter before this bid is withdrawn, the undersigned will execute and deliver to District a contract in the form attached hereto in accordance with the bid as accepted, and that it will also furnish and deliver to District the Performance Bond and Payment Bond for the Public Works as specified, all within ten (10) days after receipt of notification of award, and that the work under the contract shall be commenced by the undersigned bidder, if awarded the Contractor, on the date to be stated in District's Notice to Contractors to Proceed, and shall be completed by the Contractor in the time specified in the contract documents.
6. Notice of acceptance or requests for additional information should be addressed to the undersigned at the address identified in Paragraph 8 below.
7. Print/type the names of all persons interested in the foregoing proposal as principals in the space provided below:

(IMPORTANT NOTICE: If bidder or other interested person is a corporation, state legal name of corporation, also names of the president, secretary, treasurer, and manager thereof; if a co-partnership, state true name of firm, also names of all individual co-partners composing firm; if bidder or other interested person is an individual, state first and last names in full.)

8. Licensed in accordance with act providing for the registration of Contractors:

Company Name: _____

Company Address: _____

Contact Name: _____

Contact Email: _____
 Phone #: _____
 License #: _____ Expiration Date: _____
 Classification(s): _____
 DIR Registration #: _____ Expiration Date: _____
 Gross Annual Receipts for Firm: _____
 Years in Business: _____

9. The undersigned certifies that he/she is now licensed in the appropriate trade in accordance with the provisions of the Contractor's License Law of the State of California, and the number of said license is _____ and that said license expires _____, 20__.
10. By my signature on this proposal I certify, under penalty or perjury under the laws of the State of California, that the foregoing questionnaire and statements of Public Contract Code sections 10162, 10232 and 10285.1 are true and correct and that the bidder has complied with the requirements of section 8103 of the Fair Employment and Housing Commission Regulations (Chapter 5, Title 2 of the California Administrative Code). By my signature on this proposal I further certify, under penalty or perjury under the laws of the State of California and the United States of America, that the Non-collusion Affidavit required by Title 23 United States Code, section 112 and Public Contract Code section 7106; and the Title 49 Code of Federal Regulations, Part 29 Debarment and Suspension Certification are true and correct.

 Name of Bidder

Date: _____

By: _____
 (Signature of Bidder)

 (Print/Type Signator's Name)

 (Print/Type Title)

NOTE: If bidder is a corporation, the legal name of the corporation shall be set forth above, together with the signatures of authorized officers or agents, and the document shall bear the corporate seal; if bidder is a partnership, the true name of the firm shall be set forth above, together with the signature of the partner or partners authorized to sign contracts on behalf of the partnership; and if bidder is an individual, his/her signature shall be placed above.

Address: _____

Telephone: _____ Fax: _____
Email: _____

NON-COLLUSION AFFIDAVIT TO BE EXECUTED BY BIDDER AND SUBMITTED WITH BID

State of California

County of Imperial

_____ [name of individual], being first duly sworn, deposes and says that he or she is _____ [title of individual] of _____ [name of business] the party making the foregoing bid that the bid is not made in the interest of, or on behalf of, any undisclosed person, partnership, company, association, organization, or corporation; that the bid is genuine and not collusive or sham; that the bidder has not directly or indirectly induced or solicited any other bidder to put in a false or sham bid, and has not directly or indirectly colluded, conspired, connived, or agreed with any bidder or anyone else to put in a sham bid, or that anyone shall refrain from bidding; that the bidder has not in any manner, directly or indirectly, sought by agreement, communication, or conference with anyone to fix the bid price of the bidder or any other bidder, or to fix any overhead, profit, or cost element of the bid price, or of that of any other bidder, or to secure any advantage against the public body awarding the contract of anyone interested in the proposed contract; that all statements contained in the bid are true; and, further, that the bidder has not, directly or indirectly, submitted his or her bid price or any breakdown thereof, or the contents thereof, or divulged information or data relative thereto, or paid, and will not pay, any fee to any corporation, partnership, company association, bid depository, or to any member or agent thereof to effectuate a collusive or sham bid.

Signature

DESIGNATION OF SUBCONTRACTORS

In compliance with the Subletting and Subcontracting Fair Practices Act (Ch. 4 (commencing at section 4100), Div. 2, part 1 of the Cal. Pub. Cont. Code) and any amendments thereof, each bidder shall set forth below:

(a) (1) The name, the location of the place of business, the California contractor license number, and public works contractor registration number issued pursuant to Section 1725.5 of the Labor Code of each subcontractor who will perform work or labor or render service to the prime contractor in or about the construction of the work or improvement, or a subcontractor licensed by the State of California who, under subcontract to the prime contractor, specially fabricates and installs a portion of the work or improvement according to detailed drawings contained in the plans and specifications, in an amount in excess of one-half of 1 percent of the prime contractor's total bid or, in the case of bids or offers for the construction of streets or highways, including bridges, in excess of one-half of 1 percent of the prime contractor's total bid or ten thousand dollars (\$10,000), whichever is greater.

(b) the portion of the work which will be done by each subcontractor under this act. The prime Contractor shall list only one subcontractor for each such portion as is defined by the prime Contractor in this bid.

If a prime contractor fails to specify a subcontractor or if a prime contractor specifies more than one subcontractor for the same portion of work to be performed under the contract in excess of one-half of 1 percent of the prime contractor's total bid, the prime contractor agrees that he or she is fully qualified to perform that portion himself or herself, and that the prime contractor shall perform that portion itself.

No prime Contractor whose bid is accepted shall (a) substitute any subcontractor, (b) permit any subcontractor to be voluntarily assigned or transferred or allow it to be performed by anyone other than the original subcontractor listed in the original bid, or (c) sublet or subcontract any portion of the work in excess of one-half of one percent (1/2%) of 1 percent of the prime Contractor's total bid as to which his original bid did not designate a subcontractor, except as authorized in *Subletting and Subcontracting Fair Practices Act*.

Subletting or subcontracting of any portion of the work in excess of one-half of one percent (1/2%) of 1 percent of the prime Contractor's total bid as to which no subcontractor was designated in the original bid shall only be permitted in cases of public emergency or necessity, and then only after a finding reduced to writing as a public record of the authority awarding this contract setting forth the facts constituting the emergency or necessity.

If all work is to be done without subcontractors, write "None" in the following space:

SUBCONTRACTOR LIST

For each Subcontractor that will perform a portion of the Work in an amount in excess of one-half of 1% of the Bidder's total contract Price, the bidder must list a description of the Work, the name of the Subcontractor, its California contractor license number, the location of its place of business, its DIR registration number, and the portion of the Work that the Subcontractor is performing based on a percentage of the Base Bid price.

TYPE OF WORK SUBCONTRACTOR WILL DO	NAME UNDER WHICH SUBCONTRACTOR IS LICENSED	CALIFORNIA CONTRACTOR LICENSE NO.	ADDRESS	DIR REG. NO.	PERCENT OF WORK

SUPPLIERS

NAME OF SUPPLIER	ADDRESS & TELEPHONE No.	TYPE OF MATERIAL

Name of Bidder

By: _____
(Signature of Bidder)

(Print/Type Signator's Name)

(Print/Type Title)

PUBLIC CONTRACT CODE SECTION 10162 QUESTIONNAIRE

In accordance with Public Contract Code section 10162, the Bidder shall complete, under penalty of perjury, the following questionnaire:

Has the bidder, any officer of the bidder, or any employee of the bidder who has a proprietary interest in the bidder, ever been disqualified, removed or otherwise prevented from bidding on, or completing a federal, state or local government project because of a violation of law or a safety regulation?

Yes _____ No _____

If the answer is yes, explain the circumstances in the following space.

PUBLIC CONTRACT SECTION 10232 STATEMENT

In accordance with Public Contract Code section 10232, the Contractor hereby states, under penalty of perjury, that no more than one final unappealable finding of contempt of court by a federal court has been issued against the Contractor within the immediately preceding two year period because of the Contractor's failure to comply with an order of a federal court which orders the Contractor to comply with an order of the National Labor Relations Board.

TITLE 23, UNITED STATES CODE, SECTION 112 NON-COLLUSION AFFIDAVIT

In accordance with Title 23, United States Code, section 112, the bidder hereby states under penalty of perjury, that he has not, either directly or indirectly, entered into any agreement, participated in any collusion, or otherwise taken any action in restraint of free competitive bidding in connection with this contract.

Note: The above Statement questionnaire, and Non-Collusion Affidavit are part of the Proposal. Signing this Proposal on the signature portion thereof shall also constitute Signature of this Statement, Questionnaire, and Non-Collusion Affidavit.

Bidders are cautioned that making a false certification may subject the certifier to criminal prosecution.

PUBLIC CONTRACT CODE SECTION 10285.1 STATEMENT

In accordance with Public Contract Code section 10285.1 (Chapter 376, Stat. 1985), the bidder hereby declares under penalty of perjury under the laws of the State of California that the bidder **has** _____, **has not** _____ been convicted within the preceding three (3) years of any offenses referred to in that section, including any charge of fraud, bribery, collusion, conspiracy, or any other act in violation of any state of federal antitrust law in connection with the bidding upon, award of, or performance of, any public works contract,

as defined in Public Contract Code section 1101, with any public entity, as defined in Public Contract Code section 1100, including the Regents of the University of California or the Trustees of the California State University. The term "bidder" is understood to include any partner, member, officer, director, responsible managing officer, or responsible managing employee thereof, as referred to in section 10285.1

NOTE: THE BIDDER MUST PLACE A CHECK MARK AFTER "HAS" or "HAS NOT" IN ONE OF THE BLANK SPACES PROVIDED.

THE ABOVE STATEMENT IS PART OF THE PROPOSAL. SIGNING THIS PROPOSAL ON THE SIGNATURE PORTION THEREOF SHALL ALSO CONSTITUTE SIGNATURE OF THIS STATEMENT.

BIDDERS ARE CAUTIONED THAT MAKING A FALSE CERTIFICATION MAY SUBJECT THE CERTIFIER TO CRIMINAL PROSECUTION.

CONTRACTOR'S CERTIFICATE REGARDING WORKERS COMPENSATION

Labor Code section 3700 in relevant part provides:

"Every employer except the State shall secure the payment of compensation in one or more of the following ways:

- (a) By being insured against liability to pay compensation in one or more insurers duly authorized to write compensation insurance in this State.
- (b) By securing from the Director of Industrial Relations a *Certificate of Consent to Self Insure*, either as an individual employer, or as one employer in a group of employers, which may be given upon furnishing proof satisfactory to the Director of Industrial Relations of ability to be self-insured and to pay any compensation that may become due to his or her employees."

I am aware of the provisions of section 3700 of the Labor Code which require every employer to be insured against liability for workers compensation or to undertake self insurance in accordance with the provisions of that Code, and I will comply with such provisions before commencing the performance of the work of this contract.

Name of Bidder

By: _____
(Signature of Bidder)

(Print/Type Signator's Name)

(Print/Type Title)

(In accordance with Article 5 (commencing at section 1860), Chapter 1, Part 7, Division 2 of the Labor Code, the above certificate must be signed and filed with the awarding body prior to performing any work under this contract.)

BID BOND

KNOW ALL MEN BY THESE PRESENTS, that we _____ as Principal, and as Surety, are held and firmly bound unto the _____ District, hereinafter called District, in the penal sum of TEN PERCENT (10%) OF THE TOTAL AMOUNT OF THE BID of the Principal submitted to District for the work described below for the payment of which sum in lawful money of the United States, well and truly to be made, we bind ourselves, our heirs, executors, administrators, successors and assigns, jointly and severally, firmly by these presents.

THE CONDITION OF THIS OBLIGATION IS SUCH that whereas the Principal has submitted the accompanying bid dated _____, 20 _____, for

**SALTON COMMUNITY SERVICES DISTRICT
SALTON CITY PARK
RESTROOM IMPROVEMENTS**

DISTRICT PROJECT NO. SCP-1

NOW, THEREFORE, if the Principal shall not withdraw said bid within the period specified therein after the opening of the same, or, if no period be specified, within ninety (90) days after said opening, and if the Principal is awarded the contract, and shall within the period specified therefore, or, if no period be specified, within five (5) days after the prescribed forms are presented to it for signature, enter into the written contract with District in accordance with the bid as accepted and give bond with good and sufficient surety or sureties, as may be required, for the faithful performance and proper fulfillment of such contract and for the payment for labor and materials used for the performance of the contract, or in the event of the withdrawal of said bid within the period specified or the failure to enter into such contract and give such bonds within the time specified, if the Principal shall pay District the difference between the amount specified in said bid and the amount for which District may procure the required work and/or supplies, if the latter amount be in excess of the former; together with all costs incurred by District in again calling for bids, then the above obligation shall be void and of no effect, otherwise to remain in full force and virtue.

Surety, for value received, hereby stipulates and agrees that no change, extension of time, alterations or addition to the terms of the contract on the call for bids, or to the work to be performed thereunder, or the specifications accompanying the same, shall in anywise affect its obligation under this bond, and it does hereby waive notice of any such change, extension of time, alteration or addition to the terms of said contract or the call for bids, or to the work, or to the specifications.

In the event suit is brought upon this bond by District and judgment is recovered, Surety shall pay all costs incurred by District in such suit, including reasonable attorneys' fees to be fixed by the Court.

IN WITNESS WHEREOF, the above-bound parties have executed this instrument under their several seals this _____ day of _____, 20 _____, the

name and corporate seal of each corporate party being hereto affixed, and these presents duly signed by its undersigned representative, pursuant to authority of its governing body.

(Corporate Seal)

Proper Name of Principal

By: _____
(Signature)

(Print/Type Signator's Name)

(Print/Type Title)

(Corporate Seal)

Proper Name of Surety

By: _____
(Signature)

(Print/Type Signator's Name)

(Print/Type Title)

(Attached Attorney-In-Fact Certificate)

PERFORMANCE BOND

Whereas, the Board of Directors of the Salton Community Services District, and _____, (hereinafter designated as "principal") have entered into an agreement whereby principal agrees to install and complete certain designated public improvements, which said agreement, dated _____, 20____, and identified as project **Salton Community Services District, SALTON CITY PARK – RESTROOM IMPROVEMENTS, District Project No. SCP-1** is hereby referred to and made a part hereof; and

Whereas, Said principal is required under the terms of said agreement to furnish a bond for the faithful performance of said agreement.

Now, therefore, we, the principal and _____ (hereinafter designated as "surety"), are held and firmly bound unto the Salton Community Services District (hereinafter designated as "District") in the penal sum of _____ dollars (\$_____) lawful money of the United States, for the payment of which sum well and truly to be made, we bind ourselves, our heirs, successors, executors and administrators, jointly and severally, firmly by these presents.

The condition of this obligation is such that if the above-bounded principal, his or its heirs, executors, administrators, successors or assigns, shall in all things stand to and abide by, and well and truly keep and perform the covenants, conditions and provisions in the said agreement and any alteration thereof made as therein provided, on his or their part, to be kept and performed at the time and in the manner therein specified, and in all respects according to their true intent and meaning, and shall indemnify and save harmless District, its officers, agents and employees, as therein stipulated, then this obligation shall become null and void; otherwise it shall be and remain in full force and effect.

As a part of the obligation secured hereby and in addition to the face amount specified therefore, there shall be included costs and reasonable expenses and fees, including reasonable attorneys' fees, incurred by District in successfully enforcing such obligation, all to be taxed as costs and included in any judgment rendered.

The surety hereby stipulates and agrees that no change, extension of time, alteration or addition to the terms of the agreement or to the work to be performed thereunder or the specifications accompanying the same shall in anywise affect its obligations on this bond, and it does hereby waive notice of any such change, extension of time, alteration or addition to the terms of the agreement or to the work or to the specifications.

In witness whereof, this instrument has been duly executed by the principal and surety above named, on _____, 20_____.

Principal

By: _____

Surety

By: _____

Attorney-In-Fact

[Attach Required Acknowledgment]

PAYMENT BOND

Whereas, The Board of the Salton Community Services District, County of Imperial, State of California, and _____ hereinafter designated as “the principal”) have entered into an agreement whereby the principal agrees to install and complete certain designated public improvements, which agreement, dated _____, 20____, and identified as project **Salton Community Services District, SALTON CITY PARK – RESTROOM IMPROVEMENTS, District Project No. SCP-1**, is hereby referred to and made a part hereof; and

Whereas, Under the terms of the agreement, the principal is required before entering upon the performance of the work, to file a good and sufficient payment bond with the Salton Community Services District to secure the claims to which reference is made in Title 3 (commencing with section 9000) of Part 6 of Division 4 of the Civil Code.

Now, therefore, the principal and the undersigned as corporate surety, are held firmly bound unto the Salton Community Services District and all contractors, subcontractors, laborers, material suppliers, and other persons employed in the performance of the agreement and referred to in Title 3 (commencing with section 9000) of Part 6 of Division 4 of the Civil Code in the sum of _____ dollars (\$_____), for materials furnished or labor thereon of any kind, or for amounts due under the Unemployment Insurance Act with respect to this work or labor, that the surety will pay the same in an amount not exceeding the amount hereinabove set forth, and also in case suit is brought upon this bond, will pay, in addition to the face amount thereof, costs and reasonable expenses and fees, including reasonable attorneys’ fees, incurred by the Salton Community Services District in successfully enforcing this obligation, to be awarded and fixed by the court, and to be taxed as costs and to be included in the judgment therein rendered.

It is hereby expressly stipulated and agreed that this bond shall inure to the benefit of any and all persons, companies, and corporations entitled to file claims under Title 3 (commencing with section 9000) of Part 6 of Division 4 of the Civil Code, so as to give a right of action to them or their assigns in any suit brought upon this bond.

Should the condition of this bond be fully performed, then this obligation shall become null and void, otherwise it shall be and remain in full force and effect.

The surety hereby stipulates and agrees that no change, extension of time, alteration, or addition to the terms of the agreement or the specifications accompanying the same shall in any manner affect its obligations on this bond, and it does hereby waive notice of any such change, extension, alteration, or addition.

In witness whereof, this instrument has been duly executed by the principal and surety above named, on _____, 20_____.

Principal

By: _____

Surety

By: _____

Attorney-In-Fact

[Attach Required Acknowledgment]

CONTENTS OF GENERAL CONDITIONS

Article 1.	DEFINITIONS	31
Article 2.	DRAWINGS AND SPECIFICATIONS.....	31
Article 3.	COPIES FURNISHED.....	31
Article 4.	OWNERSHIP OF DRAWINGS.....	31
Article 5.	DETAIL DRAWINGS AND INSTRUCTIONS	32
Article 6.	TIME FOR COMPLETION AND DAMAGES FOR DELAY	32
Article 7.	PROGRESS SCHEDULE	32
Article 8.	CONTRACT SECURITY	32
Article 9.	ASSIGNMENT	32
Article 10.	PROHIBITED INTERESTS	32
Article 11.	SEPARATE CONTRACTS	33
Article 12.	SUBCONTRACTING.....	33
Article 13.	DEFAULTS & REMEDIES	34
Article 14.	WARRANTIES	36
Article 15.	NOTICES AND REPORTS.....	36
Article 16.	WORKERS.....	37
Article 17.	PREVAILING WAGE AND PAYROLL RECORDS	37
Article 18.	APPRENTICES.....	39
Article 19.	HOURS OF WORK	39
Article 20.	INSURANCE COVERAGES	39
Article 21.	SPECIAL INSURANCE REQUIREMENTS	40
Article 22.	INSURANCE ENDORSEMENTS, CLAUSES, & INFORMATION	41
Article 23.	PROOF OF INSURANCE	41
Article 24.	CHOICE OF LAW.....	42
Article 25.	PERMITS AND LICENSES	42
Article 26.	EASEMENTS	42
Article 27.	SURVEYS	42
Article 28.	EXCISE TAXES.....	42
Article 29.	PATENTS AND ROYALTIES	42
Article 30.	MATERIALS	42
Article 31.	SUBSTITUTIONS.....	43
Article 32.	SHOP DRAWINGS.....	44
Article 33.	SAMPLES	44
Article 34.	COST BREAKDOWN AND PERIODICAL ESTIMATES	44

Article 35.	PAYMENTS	45
Article 36.	PAYMENT WITHHELD	45
Article 37.	CHANGES AND EXTRA WORK	46
Article 38.	DEDUCTIONS FOR UNCORRECTED WORK	46
Article 39.	PAYMENTS BY CONTRACTOR	46
Article 40.	CONTRACTOR'S SUPERVISION.....	46
Article 41.	INSPECTOR'S FIELD OFFICE	47
Article 42.	DOCUMENTS ON WORK.....	47
Article 43.	UTILITIES AND RELOCATION	47
Article 44.	SANITARY FACILITIES.....	48
Article 45.	TRENCHES	48
Article 46.	PROTECTION OF WORK AND PROPERTY	49
Article 47.	LAY OUT AND FIELD ENGINEERING.....	50
Article 48.	CUTTING AND PATCHING	50
Article 49.	CLEANING UP	50
Article 50.	CORRECTION OF WORK	50
Article 51.	ACCESS TO WORK	51
Article 52.	OCCUPANCY.....	51
Article 53.	DISTRICT'S INSPECTOR.....	51
Article 54.	TESTS AND INSPECTIONS	51
Article 55.	SOILS INVESTIGATION REPORT	52
Article 57.	INDEMNITIES	52
Article 58.	PROVISIONS REQUIRED BY LAW DEEMED INSERTED	52
Article 59.	LABOR - EMPLOYMENT SAFETY.....	53
Article 60.	NOTICE OF TAXABLE POSSESSORY INTEREST.....	53
Article 61.	ASSIGNMENT OF UNFAIR BUSINESS PRACTICES CLAIMS (CLAYTON ACT AND CARTWRIGHT ACT)	53
Article 62.	SUBSTITUTION OF SECURITY	53
Article 63.	NON-DISCRIMINATION AND DISADVANTAGED BUSINESS ENTERPRISE PROGRAM	54
Article 64.	SPECIAL CONDITIONS.....	54
Article 65.	CONTRACT CONSTRUCTION.....	54
Article 66.	COGNIZANCE OF VIOLATIONS BY District.....	55
Article 67.	LABOR STANDARDS COMPLIANCE REQUIREMENTS.....	55
Article 68.	CONFLICT OF INTEREST AND GRATUITIES	56
Article 70.	INELIGIBILITY	60

Article 71.	RESOLUTION OF CLAIMS.....	60
Article 72.	MISCELLANEOUS.....	62

GENERAL CONDITIONS

Article 1. DEFINITIONS

- (a) District and Contractor are those mentioned as such in the Agreement. They are treated throughout the Agreement as if they are of singular number and neuter gender.
- (b) Subcontractor, as used herein, includes those having direct contract with Contractor and one who furnishes material work to a special design according to plans and specifications of this work, but does not include one who merely furnishes material not so worked.
- (c) Surety is the person, firm, or corporation that executes as surety the *Contractor's Performance Bond* and *Payment Bond for the Public Works*.
- (d) Provide shall include "provide complete in place," that is, "furnish and install."
- (e) As Shown, As Indicated, As Detailed, refer to drawings accompanying these specifications.
- (f) Work of the Contractor or subcontractor includes labor or materials, or both.

Article 2. DRAWINGS AND SPECIFICATIONS

Contract Documents are complementary, and what is called for by one shall be as binding as if called for by all. The intention of documents is to include all labor and materials, equipment, and transportation necessary for the proper execution of work. Materials or work described in words which so apply have a well-known technical or trade meaning, and shall be deemed to refer to such recognized standards.

Interpretations. Figured dimensions on drawings shall govern, but work not dimensioned shall be as directed. Work not particularly shown or specified shall be the same as similar parts that are shown or specified. Large-scale details shall take precedence over smaller scaled drawings as to shape and details of construction. Specifications shall govern as to materials, workmanship, and installation procedures. Drawings and specifications are intended to be fully cooperative and to agree. However, if Contractor observes that drawings and specifications are in conflict, it shall promptly notify the Architect in writing, and any necessary changes shall be adjusted as provided in the contract for changes in work.

Misunderstanding of drawings and specifications shall be clarified by the Architect, whose decision shall be final.

Standards, Rules, and Regulations referred to are recognized printed standards, and shall be considered as one and a part of these specifications within limits specified.

Article 3. COPIES FURNISHED

Contractor will be furnished, free of charge, copies of drawings and specifications as set forth in *Special Conditions*. Additional copies may be obtained at cost of reproduction.

Article 4. OWNERSHIP OF DRAWINGS

All drawings, specifications, and copies thereof furnished by District are its property. They are not to be used on other work, and, with exception of signed contract sets, are to be returned to District on request at completion of work.

Article 5. DETAIL DRAWINGS AND INSTRUCTIONS

- (a) In case of ambiguity, conflict, or lack of information, Architect/Engineer shall furnish with reasonable promptness additional instructions, by means of drawings or otherwise, necessary for proper execution of work. All such drawings and instructions shall be consistent with contract documents, true developments thereof, and reasonably inferable therefrom.
- (b) Work shall be executed in conformity therewith, and Contractor shall do no work without proper drawings and instructions.

Article 6. TIME FOR COMPLETION AND DAMAGES FOR DELAY

The Parties recognize that time is of the essence of the Agreement and that District will suffer financial loss if the Work is not completed by the date set forth in Paragraph 19.9 of the Information to Bidders section of this Agreement. The Parties also recognize the delays, expense and difficulties involved with proving in a legal proceeding the actual loss suffered by District if the Work is not completed on time. Therefore, Contractor acknowledges that time is of the essence, and they shall complete the project under the agreed upon schedule as referenced in Article 7.

Article 7. PROGRESS SCHEDULE

Immediately after being awarded contract, Contractor shall prepare an estimated progress schedule (using the Critical Path Method (CPM) through a software program selected by District but at Contractor's sole expense) and submit the schedule for District's approval. Schedule shall indicate graphically the beginning and completion dates of all phases of construction. An updated progress schedule shall be submitted to District on a monthly basis.

Article 8. CONTRACT SECURITY

Unless otherwise specified, Contractor shall furnish a surety bond in an amount equal to one hundred percent (100%) of the contract price as security for faithful performance of this contract, and shall furnish a separate bond in an amount equal to one hundred percent (100%) of the contract price as security for payment of persons performing labor and furnishing materials in connection with this contract. Aforesaid bonds shall be in form set forth in these contract documents. Upon request of Contractor, District will consider and accept multiple sureties on such bonds. District may reject at its discretion any bond issued by a surety that to District's satisfaction does not have a sufficient bond rating or history as a surety in the State of California to assure adequate security to District for the default of Contractor.

Article 9. ASSIGNMENT

Contractor shall not assign this contract or any part thereof without prior written consent of District. Any assignment of money due to or to become due under this contract shall be subject to a prior lien for services rendered or material supplied for performance of work called for under said contract in favor of all persons, firms, or corporations rendering such services or supplying such materials to the extent that claims are filed pursuant to the Civil Code, the Code of Civil Procedure, Public Contract Code and/or the Government Code.

Article 10. PROHIBITED INTERESTS

No official of District who is authorized in such capacity and on behalf of District to negotiate, make, accept or approve, or to take part in negotiating, making, accepting or

approving, any architectural, engineering, inspection, construction, or material supply contract or any subcontract in connection with construction or project shall become directly or indirectly interested financially in this contract or in any part thereof. No officer, employee, architect, attorney, engineer, or inspector of or for District who is authorized in such capacity and on behalf of District to exercise any executive, supervisory, or other similar functions in connection with construction of project shall become directly or indirectly interested financially in this contract or in any part thereof.

Article 11. SEPARATE CONTRACTS

District reserves the right to let other contracts in connection with this work. Contractor shall afford other Contractors reasonable opportunity for introduction and storage of their materials and execution of their work and shall properly connect and coordinates its work with theirs.

If any part of Contractor's work depends for proper execution or results upon work of any other Contractor, the Contractor shall inspect and promptly report to Architect/Engineer any defects in such work that render it unsuitable for such proper execution and results. Contractor's failure so to inspect and report shall constitute its acceptance of other Contractor's work as fit and proper for reception of Contractor's work, except as to defects which may develop in other Contractor's work after execution of Contractor's work.

To ensure proper execution of its subsequent work, Contractor shall measure and inspect work already in place, and shall at once report to Architect any discrepancy between executed work and contract documents.

Contractor shall ascertain to its own satisfaction the scope of the project and nature of any other contracts that have been or may be awarded by District in prosecution of the project to the end that Contractor may perform its contract in the light of such other contracts, if any. Nothing herein contained shall be interpreted as granting to Contractor exclusive occupancy at site of project. Contractor shall not cause any unnecessary hindrance or delay to any other Contractor working on project. If simultaneous execution of any contract for the project is likely to cause interference with performance of some other contract or contracts, District shall decide which Contractor shall cease work temporarily and which Contractor shall continue or whether work can be coordinated so that Contractors may proceed simultaneously. District shall not be responsible for any damages suffered or extra costs incurred by Contractor resulting directly or indirectly from award or performance or attempted performance of any other contract or contracts on project, or caused by any decision or omission of District respecting the order of precedence in performance of contracts.

Article 12. SUBCONTRACTING

- (a) Contractor agrees to bind every subcontractor by terms of the contract as far as such terms are applicable to subcontractor's work. If Contractor shall subcontract any part of this contract, Contractor shall be as fully responsible to District for acts and omissions of Contractor's subcontractor and of persons either directly or indirectly employed by Contractor's subcontractor as it is for acts and omissions of persons directly employed by itself. Nothing contained in the contract documents shall create any contractual relation between any subcontractor and District.

- (b) District's consent to or approval of any subcontractor under this contract shall not in any way relieve Contractor of its obligations under this contract, and no such consent or approval shall be deemed to waive any provision of this contract.
- (c) Substitution or addition of subcontractors shall be permitted only as authorized by California Public Contract Code sections 4100, et seq.
- (d) Contractor represents and warrants that it and its subcontractors are not ineligible to work for District due to violations of Labor Code sections 1777.1 and 1777.7.

Article 13. DEFAULTS & REMEDIES

- (a) Default. In the event that (i) Contractor files a petition requesting relief under any bankruptcy act, or is adjudged as bankrupt, or makes a general assignment for the benefit of creditors or has a receiver appointed on account of its insolvency, or (ii) Contractor refuses or is unable, for whatever reason, to supply enough properly skilled workers or proper materials to complete the Project, or (iii) Contractor fails to follow the directions of District, or (iv) Contractor fails to make prompt payment to its subcontractors and suppliers for materials or labor supplied or permits any lien to be imposed upon all or any portion of the Project, or (v) Contractor disregards any laws or orders of any public or private authority having jurisdiction over the Work or the Project, or (vi) Contractor fails to perform in accordance with any of the terms of this Agreement or breaches any provision of this Agreement, District may give notice of such failure or breach to Contractor, identifying the failure or breach of this Agreement. Should any such failure or breach continue for twenty-four (24) hours after delivery of notice without a good faith effort on the part of Contractor to commence all necessary corrective action, or should such a breach continue despite Contractor's efforts for forty-eight (48) hours, then at that time such failure shall be deemed a default by Contractor under this Agreement and District shall have all rights and remedies available at law or in equity, including the right to terminate this Agreement. Without limiting its rights and remedies, District may then proceed as follows:
 - (1) Without terminating this Agreement or the obligations of Contractor hereunder as to all of the Work required to be performed or furnished by Contractor pursuant to this Agreement, District may require Contractor, at Contractor's expense, to cure such default(s) as may exist in the performance of Contractor's obligations hereunder within forty-eight (48) hours after such default(s) has/have occurred including but not limited to repairing, replacing, and correcting material or Work determined by District to be defective or not complying with the requirements of this Agreement. Should Contractor fail to timely repair, replace, and/or correct non-complying or defective materials and workmanship or otherwise cure its default(s) hereunder, and in the case of emergencies in which case District may act immediately if Contractor is not available or is not responding, and without further notice, District may make required repairs, replacements and other corrections or otherwise remedy the default by Contractor pursuant to Paragraph (2) below.
 - (2) Without terminating this Agreement or the obligations of Contractor hereunder as to all of the Work required to be performed or furnished by Contractor pursuant to this Agreement, District may engage another contractor to perform such portion of Contractor's Work required pursuant to this Agreement or

furnish any materials or other items required hereunder as District in its sole discretion may deem necessary to avoid delay in the progress of the Work, and in connection therewith, District may perform such Work or any portion thereof itself or have the same performed by others and District may procure all necessary materials, equipment or other items required for the continued progress of such Work. The costs incurred by District as a result of engaging another Contractor shall be deducted from the compensation payable pursuant to this Agreement and if District's costs exceed or may reasonably be anticipated to exceed the balance of the compensation due to Contractor for such work, such excess, or anticipated excess, shall be immediately due and owing from Contractor to District and may be withheld from any funds due to Contractor pursuant to this Agreement or any other agreement.

- (3) District may terminate Contractor's right to perform upon written notice and District shall then have the option of completing the Work or any portion thereof by exercise of its interest under the performance bond issued in favor by Contractor, or having such Work in whole or in part be completed by others for Contractor's account. A calculation shall take place at the conclusion of the Project wherein to the degree the sum of District's costs and any amounts paid to complete the Project exceed the compensation payable pursuant to this Agreement, then any such excess shall be immediately due and owing from Contractor to District.
- (b) Damages. Contractor shall be liable for all damages suffered by District by reason of Contractor's default in any provision of this Agreement and the exercise of District of its option to terminate this Agreement shall not release Contractor of such liability. Contractor shall have no right to receive any further payment after a default has occurred until such time as the Work to be performed by Contractor pursuant hereto has been completed and accepted by District and damages suffered by District, if any, ascertained. Damages shall include by way of illustration, but not of exclusion, District's costs of completing the Work which exceeds the compensation payable pursuant to this Agreement, other general, liquidated, special or consequential damages, attorney fees, and costs.
- (c) Actions After Default. Should District exercise any of its options, remedies, or rights granted pursuant to the terms of this Agreement in the event of a default by Contractor, District at its sole election may, but shall not be obligated to, use any materials, supplies, tools or equipment on the work site which belong to Contractor to complete the Work required to be completed by Contractor, whether such work is completed by District or by others, and Contractor agrees that it shall not remove such materials, supplies, tools and equipment from the work site unless directed in writing by District to do so.
- (d) Limit on Force Majeure Damages. Contractor shall not be responsible for repairing or restoring damage to work caused by an act of God, provided that the work damaged is built in accordance with accepted and applicable building standards and the plans and specifications of District. In the event of such damage, District may, at its option, elect to terminate this Agreement. For purposes of this Agreement, an "act of God" shall be defined as an earthquake in excess of 3.5 on the Richter scale and a tidal wave.

- (e) No Limitation of Rights. The options and rights granted to District herein shall not be deemed as limitations upon the other rights and remedies of District in the event of a failure of performance or breach by Contractor, and District shall be entitled to exercise the rights and remedies hereinabove specified and all other rights and remedies which may be provided in this Agreement or by law or in equity, either cumulatively or consecutively, and in such order as District in its sole discretion shall determine.

Article 14. WARRANTIES

- (a) One-Year Warranty. Contractor agrees to provide a one-year warranty for all of its work and component parts and guarantees that all work shall be performed in a professional and workman-like manner and be free from defects. Contractor guarantees to timely correct all work performed by it under this Agreement which District determines to be defective in design, material, and/or workmanship within a period of one (1) year from the date of the completion of the Work. The warranties set forth in this Agreement shall be in addition to, and not in lieu of, all other statutory and case law warranties and obligations of Contractor. Contractor expressly agrees that all warranties made by Contractor, all obligations under this Agreement and all remedies for breach of such warranties shall survive this Agreement in the event it is terminated or expires for any reason prior to the running of the full warranty periods listed above. Note: Product Warranty on specifications.
- (b) Materials. All materials furnished by Contractor shall be new, manufactured during the current year, of first quality, and carrying full manufacturer’s warranty. Contractor shall be responsible for any expiration of manufacturer or other warranties of material or equipment being supplied for this Agreement. Contractor guarantees that all warranties of material and equipment shall become effective when the project is accepted by District’s Board of Supervisors, not at time of installation by Contractor.
- (c) Manufacturers’ Warranty Information. Contractor agrees to promptly provide such information and maintenance recommendations to District at the inception of Contractor’s work to the extent such information is reasonably available. In the event of failure of Contractor to comply with above-mentioned conditions within one (1) week after being notified in writing, District is hereby authorized to proceed to have defects repaired and made good at expense of Contractor, who hereby agrees to pay costs and charges therefore immediately on demand.

Article 15. NOTICES AND REPORTS

- (a) All notices and reports under this Agreement shall be in writing and may be given by personal delivery or by mailing by certified mail, addressed as follows:

<u>District</u>	<u>Contractor</u>
Salton Community Services District	Business Name:
Attention: General Manager	_____
1209 Van Buren Blvd.	Address:
Salton City, CA 92274	_____

- (b) Notices and reports under this Agreement may be given by personal delivery or by mailing by certified mail at such other address as either Party may designate in a notice to the other Party given in such manner. Any notice given by mail shall be considered given when deposited in the United States Mail, postage prepaid, addressed as provided herein.

Article 16. WORKERS

- (a) Contractor shall at all times enforce strict discipline and good order among its employees, and shall not employ on work any unfit person or anyone not skilled in work assigned to that person. Contractor shall at all times enforce rules and standards regarding sensitive information. Contractor shall not permit workers to touch or otherwise touch, read, review, copy, or access any sensitive or confidential information. Contractor shall be responsible for any worker violating sensitive information standards.
- (b) Any person in the employ of the Contractor whom District may deem incompetent or unfit shall be dismissed from work, and shall not again be employed on it except with written consent of District.
- (c) Contractor shall provide District with a list of all current employees. Contractor shall notify District of all new employees one week prior to their start date.
- (d) All Contractor's employees shall be required to comply with the work rules established for the project site; and shall be identified while on the premises by picture identification card furnished at his/her expense, indicating their name or number; and by shirt, blouse or smock indicating the company name or logo in print large enough to be easily read. Contractor's employees shall have effective communication skills to perform such tasks and communicate with the District and its representatives.
- (e) It shall be the responsibility of Contractor to ensure all workers do not access sensitive information. District shall have the right to perform a background check and clearance requirements of all workers that have access to sensitive information. Notwithstanding anything in this agreement to the contrary, the Contractor must comply with background check and clearance requirements of the California Department of Justice (DOJ) and the California Department of Motor Vehicles (DMV) relating to any Contractor employee who has physical access to any area which is either connected to, or contains records from, the DOJ criminal computer database, including without limitation, the California Law Enforcement Telecommunications System and the Criminal Offender Record Information, or the DMV computer database (collectively, "the Databases"). If requested by the District, the Contractor must provide to the District suitable documentation evidencing the Contractor's compliance with the policies, practices, and procedures of the DOJ and the DMV regarding background check and clearance requirements relating to access to the Databases.

Article 17. PREVAILING WAGE AND PAYROLL RECORDS

- (a) Contractor agrees to comply with sections 1775 and 1776 of the California Labor Code relating to the payment of prevailing wage and the maintenance of certified payroll records and to make the certified payroll records available for inspection at

all reasonable hours at Contractor's principal office. For those Public Works Projects that are subject to the State Department of Industrial Relations (DIR), Division of Labor Standards Enforcement (DLSE) compliance monitoring and enforcement it is the Contractor's responsibility to submit certified payroll records directly to the state Compliance Monitoring Unit (CMU). More information concerning state compliance can be found at <https://www.dir.ca.gov/Public-Works/publicworks.html>. The responsibility for compliance with these provisions is fixed with Contractor. Contractor understands and agrees that it shall, as a penalty to District, forfeit specific monetary fines for each worker paid less than the prevailing wage rates as determined by the Labor Commissioner for the work or craft in which the worker is employed for any Work done pursuant to this Agreement.

- (b) Notwithstanding paragraph (a), Contractor is not liable for any penalties pursuant to paragraph (a) when a subcontractor on the Project fails to pay its workers the general prevailing rate of per diem wages unless:
- (1) Contractor had knowledge of that failure of the subcontractor to pay the specified prevailing rate of wages to those workers; or
 - (2) Contractor fails to comply with all of the following requirements:
 - (A) The contract executed between Contractor and the subcontractor for the performance of Work on the Project shall include a copy of the provisions of California Labor Code sections 1771, 1775, 1776, 1777.5, 1813 and 1815; and
 - (B) Contractor shall monitor the payment of the specified general prevailing rate of per diem wages by the subcontractor to the employees, by periodic review of the certified payroll records of the subcontractor; and
 - (C) Upon becoming aware of the failure of the subcontractor to pay his or her workers the specified prevailing rate of wages, Contractor shall diligently take corrective action to halt or rectify the failure, including, but not limited to, retaining sufficient funds due the subcontractor for work performed on the public works project; and
 - (D) Prior to making final payment to the subcontractor for Work performed on the Project, Contractor shall obtain an affidavit signed under penalty of perjury from the subcontractor that the subcontractor has paid the specified general prevailing rate of per diem wages to his or her employees on the Project and any amounts due pursuant to California Labor Code section 1813.
 - (E) Prevailing Wage Compliance. Contractor and its subcontractors shall pay all workers employed on the Project the rates determined by the Director of the California Department of Industrial Relations (DIR). Copies of the State prevailing rate of per diem wages are on file with the Department of Industrial Relations, Division of Apprenticeship Standards, 445 Golden Gate Avenue, San Francisco, California, and at District's Department of Public Works, and are available to Contractor and any other interested party upon request. Contractor shall post the prevailing rate of per diem wages to be posted at the Project site.

Article 18. APPRENTICES

- (a) Contractor agrees to comply with sections 1777.5, 1777.6 and 1777.7 of the California Labor Code relating to the employment of apprentices and to provide District with copies of any contract award information and verified statements of the journeyman and apprentice hours performed pursuant to this Agreement as required by section 1777.5(e). The responsibility for compliance with these provisions is fixed with Contractor for all apprenticeable occupations, where journeymen in the craft are employed on the public work, in a ratio of not less than one (1) apprentice for each five (5) journeymen (unless an exemption is granted in accordance with section 1777.5) and Contractor and its subcontractors shall not discriminate among otherwise qualified employees as indentured apprentices on any public work solely on the ground of race, religious creed, color, national origin, ancestry, sex, or age, except as provided in California Labor Code section 3077. Only apprentices, as defined in California Labor Code section 3077, who are in training under apprenticeship standards and who have signed written apprentice agreements will be employed on public works in apprenticeable occupations. This section shall not be enforced if the not-to-exceed amount of this Agreement is less than thirty thousand dollars (\$30,000).
- (b) If the Project falls within the jurisdiction of California Labor Code section 1777.5, District shall, within five (5) days of the award, send a copy of the award to the Division of Apprenticeship Standards. In addition, District shall notify the Division of Apprenticeship Standards of a finding of any discrepancy regarding the ratio of apprentices to journeymen within five (5) days of the finding.

Article 19. HOURS OF WORK

Contractor agrees to comply with sections 1810 through 1815 of the California Labor Code and, when applicable, the Contract Work Hours and Safety Standards Act (40 USC §327 et seq.; 29 CFR Part 5) which provide that Contractor's workers and its subcontractor's workers may not be required or permitted to work more than eight (8) hours in any one (1) calendar day and forty (40) hours in any one (1) calendar week. Further, work performed by employees of Contractor or its subcontractor in excess of eight (8) hours per day, and forty (40) hours during any one (1) week, shall be compensated for all hours worked in excess of eight (8) hours per day at not less than one and one-half (1½) times the basic rate of pay. The responsibility for compliance with these provisions is fixed with Contractor. Contractor understands and agrees that it shall, as a penalty to District, forfeit specific monetary fines to District should Contractor or its subcontractors fail to comply with the provisions contained within this paragraph.

Article 20. INSURANCE COVERAGES

Contractor hereby agrees at its own cost and expense to procure and maintain, during the entire term of this Agreement and any extended term therefore, insurance in a sum acceptable to District and adequate to cover potential liabilities arising in connection with the performance of this Agreement and in any event not less than the minimum limit set forth as follows:

<u>INSURANCE</u>	<u>MINIMUM LIMIT</u>
Worker's Compensation, Coverage A	Statutory
Employers Liability, Coverage B	\$1,000,000 per accident for bodily injury or disease
<u>Commercial General Liability Including Contractual Liability</u>	
Operations, Products and Completed Operations:	
Personal/Bodily Injury	\$1,000,000 / occurrence \$2,000,000 / aggregate
Property Damage	\$1,000,000 / occurrence \$2,000,000 / aggregate
<u>Commercial Automobile Liability</u> (owned, hired, and non-owned vehicles:	
Personal/Bodily Injury & Property Damage	\$1,000,000
Unemployment Insurance	To Be Determined by Scope of Work
Disability Insurance	To Be Determined by Scope of Work
Liability Insurance	To Be Determined by Scope of Work

Article 21. SPECIAL INSURANCE REQUIREMENTS

(a) All insurance required under Article 20 shall:

- (1) Be procured from an insurer authorized to do business in California.
- (2) Be primary coverage as respects District and any insurance or self-insurance maintained by District shall be in excess of Contractor's insurance coverage and shall not contribute to it.
- (3) Name District as an additional insured on all policies, except Workers' Compensation, and provide that District may recover for any loss suffered by District by reason of Contractor's negligence.
- (4) State that it is primary insurance and regards District as an additional insured and contains a cross-liability or severability of interest clause.
- (5) Not be canceled, non-renewed, or reduced in scope of coverage until after thirty (30) days written notice has been given to District. However, Contractor may not terminate such coverage until it provides District with proof that equal or better insurance has been secured and is in place. Cancellation or change without the prior written consent of District shall, at the option of District, be grounds for termination of this Agreement.

(b) Additional Insurance Requirements.

- (1) Complete copies of certificates of insurance for all required coverages including additional insured endorsements and thirty-day (30-day) notice of cancellation clause endorsements shall be attached hereto as Exhibit E and incorporated herein as though fully set forth.

- (2) District is to be notified immediately of all insurance claims. District is also to be notified if any aggregate insurance limit is exceeded.
- (c) Nothing in this, or any other provision of this Agreement, shall be construed to preclude Contractor from obtaining and maintaining any additional insurance policies in addition to those required pursuant to this Agreement.

Article 22. INSURANCE ENDORSEMENTS, CLAUSES, & INFORMATION

- (a) The comprehensive/commercial general liability insurance shall contain a provision of endorsements stating that such insurance:
 - (1) Includes contractual liability;
 - (2) Does not contain a "pro rata" provision which looks to limit the insurer's liability to the total proportion that its policy limits bear to the total coverage available to the insured;
 - (3) Does not contain an "excess only" clause which requires the exhaustion of other insurance prior to providing coverage;
 - (4) Does not contain an "escape clause" which extinguishes the insurer's liability if the loss is covered by other insurance;
 - (5) Includes District, architect, and the construction manager as an additional insured;
 - (6) States that it is primary insurance and regards District as an additional insured and contains a cross-liability or severability of interest clause; and
 - (7) Does not contain any exclusion as to loss or damage to property caused by explosion or resulting from collapse of buildings or structures or damage to property underground, commonly referred to by insurers as the "XCU Hazards."
- (b) Certificates and insurance policies shall include the following clause: "This policy shall not be canceled or reduced in required limits of liability or amount of insurance until notice has been mailed to District stating date of cancellation or reduction. Date of cancellation may not be less than thirty (30) days after date of mailing notice."
- (c) Certificates of insurance shall state, in particular, those insured, extent of insurance, location and operation to which insurance applies, expiration date, and cancellation and reduction notice.

Article 23. PROOF OF INSURANCE

Contractor shall not commence work nor shall it allow any subcontractor to commence work under this Agreement until Contractor has obtained all required insurance, certificates and endorsements, including but not limited to, Additional Insured Endorsements and thirty days (30-days) Notice of Cancellation Clause endorsements have been delivered in duplicate to and approved by District. The above referenced insurance documents must be received by District on or before the effective date of this Agreement and shall be sent to the following address:

Salton Community Services District
Attention: General Manager
1209 Van Buren Blvd.
Salton City, CA 92274

Article 24. CHOICE OF LAW

The laws of the State of California shall govern this Agreement. This Agreement is made and entered into in Imperial County, California. Any action brought by either Party with respect to this Agreement shall be brought in a court of competent jurisdiction within said County.

Article 25. PERMITS AND LICENSES

Permits and licenses necessary for prosecution of work shall be secured and paid for by Contractor, unless otherwise specified.

Article 26. EASEMENTS

Easements for permanent structures or permanent changes in existing facilities shall be secured and paid for by District, unless otherwise specified.

Article 27. SURVEYS

Surveys to determine location of property lines and corners will be supplied by District. Surveys to determine locations of construction, grading, and site work shall be provided by Contractor.

Article 28. EXCISE TAXES

If under federal excise tax law any transaction hereunder constitutes a sale on which a federal excise tax is imposed and the sale is exempt from such excise tax because it is a sale to a state or local government for its exclusive use, District, upon request, will execute a certificate of exemption which will certify: (a) that District is a political subdivision of the state for the purpose of such exemption; and (b) that the sale is for the exclusive use of District. No excise tax for such materials shall be included in any bid price.

Article 29. PATENTS AND ROYALTIES

Contractor shall hold and save District and its officers, agents, and employees harmless from liability of any nature or kind, including cost and expense, for or on account of any patented or unpatented invention, process, article, or appliance manufactured or used in the performance of this contract, including its use by District, unless otherwise specifically stipulated in the contract documents.

Article 30. MATERIALS

Except as otherwise specifically stated in this contract, Contractor shall provide and pay for all materials, labor, tools, equipment, water, light, power, transportation, superintendence, temporary constructions of every nature, and all other services and facilities of every nature whatsoever necessary to execute and complete this contract within the specified time.

Unless otherwise specified, all materials shall be new, and both workmanship and materials shall be of good quality.

Materials shall be furnished in ample quantities and at such times as to insure uninterrupted progress of work, and shall be stored properly and protected as required. Contractor shall be entirely responsible for damage or loss by weather or other causes to materials or work under this contract. No material, supplies, or equipment for work under this contract shall be purchased subject to any chattel mortgage or under a conditional sale or other agreement by which an interest herein or in any part thereof is retained by seller or supplier. Contractor warrants good title to all material, supplies, and equipment installed or incorporated in work, and agrees upon completion of all work to deliver

premises, together with all improvements and appurtenances constructed or placed thereon by Contractor, to District free from any claims, liens, or charges. Contractor further agrees that neither Contractor nor any person, firm, or corporation furnishing materials or labor for any work covered by this contract shall have any right to lien upon premises or any improvement or appurtenance thereon, except that Contractor may install metering devices or other equipment of utility companies or of political subdivisions title to which is commonly retained by utility company or political subdivision. In event of installation of any such metering device or equipment, Contractor shall advise District as to owner thereof.

Nothing contained in this Article, however, shall defeat or impair the right of persons furnishing material or labor under any bond given by Contractor for their protection or any rights under any law permitting such persons to look to funds due Contractor in hands of District, and this provision shall be inserted in all subcontracts and material contracts, and notice of its provisions shall be given to all persons furnishing material for work when no formal contract is entered into for such material.

See Comprehensive Specifications for material requirements.

Article 31. SUBSTITUTIONS

Whenever specifications for any material, product, thing, service, or process is indicated or specified by grade, patent or propriety name or by name of manufacturer, such specifications shall be deemed to be used for the purpose of facilitating the description of material, product, thing, service, or process desired, and shall be deemed to be followed by the words "or equal", and Contractor may, unless otherwise stated, offer any material, product, thing, service or process which shall be equal or better in every respect to that so indicated or specified. If the material, product, thing, service, or process offered by Contractor is not, in the opinion of District and Architect/Engineer, equal or better in every respect to that specified, then Contractor shall furnish the material, product, thing, service, or process specified. The burden of proof as to equality of any material, product, thing, service, or process shall rest with Contractor. Contractor shall only be authorized to substitute any designated material, product, thing, service or process required under this contract if such request, together with substantiating data for substitution of an "or equal" item is timely submitted in accordance with the Calendar of Events set forth under section 19.3 of the "INFORMATION FOR BIDDERS" form and approval thereof is authorized in writing by District within the time frame set forth under Public Contract Code section 4104.5(a). Notwithstanding, in the event CONTRACTOR discovers after the stated substitution request filing deadline that a designated material, product, thing, service or process is no longer available and/or the use of the same is necessary to complete the project, CONTRACTOR may within thirty (30) days after award of the contract submit a "late substitution request", together with substantiating data for substitution of an "or equal" item for District's review and consideration. However, District shall have the sole discretion in granting such a late substitution request and shall not be required to accept the same even if the material, product, thing, service or process is equal or better in every respect.

It should be emphasized that a Contractor's request to substitute an "equal" material, product, thing or service for one designated in the contract specifications and/or District's subsequent written approval thereof, shall not in any way authorize an extension of time for performance of this contract. Moreover, in event Contractor furnishes a material,

product, thing or service that is more expensive than that specified, the difference in cost of such material, product, thing, service or process, so furnished shall be borne solely by Contractor.

Article 32. SHOP DRAWINGS

Contractor shall check and verify all field measurements, and shall submit with such promptness as to cause no delay in Contractor's own work or in that of any other Contractor three (3) copies, checked and approved by Contractor, of all shop or setting drawings, schedules and materials lists required for the work of various trades.

Architect/Engineer shall check and approve within ten (10) working days such schedules and drawings only for conformance with design concept of project, and compliance with information given in contract documents. Contractor shall make any corrections required by Architect/Engineer; file with Architect/Engineer three (3) corrected copies, and furnish such other copies as may be needed for construction. Architect/Engineer's approval of such drawings or schedules shall not relieve Contractor from responsibility for deviations from drawings or specifications unless Contractor has in writing called Architect/Engineer's attention to such deviations at time of submission and secured Architect/Engineer's written approval, nor shall it relieve Contractor from responsibility for errors in shop drawings or schedule.

Article 33. SAMPLES

Contractor shall furnish for approval, within ten (10) days following award of contract, all samples as required in specifications together with catalogs and supporting data required by Architect/Engineer. This provision shall not authorize any extension of time for performance of this contract. Architect/Engineer will check and approve such samples, within five (5) working days from receipt of same, only for conformance with design concept of work and for compliance with information given in contract documents. Work shall be in accordance with approved samples.

Article 34. COST BREAKDOWN AND PERIODICAL ESTIMATES

Contractor shall furnish on forms provided by District:

- (a) Within ten (10) days of award of contract, a detailed estimate giving complete breakdown of contract price.
- (b) A periodical itemized estimate of work done for purpose of making partial payments thereon.
- (c) Within ten (10) days of request by District, a schedule of estimated monthly payments which shall be due Contractor under the contract.

Values employed in making up any of these schedules will be used only for determining basis of partial payments, and will not be considered as fixing a basis for additions to or deductions from contract price.

- (d) **Schedule of Values.** Prior to submitting the first application for payment, Contractor must prepare and submit to the District a schedule of values apportioned to the various divisions and phases of the Work, including mobilization and demobilization. If a Bid Schedule was submitted with Contractor's bid, the amounts in the schedule of values must be consistent with the Bid Schedule. Each line item contained in the schedule of values must be assigned a value such that the total of all items equals the Contract Price. The items must be sufficiently detailed to enable accurate

evaluation of the percentage of completion claimed in each application for payment, and the assigned value consistent with any itemized or unit pricing submitted with Contractor's bid.

Article 35. PAYMENTS

- (a) Each month, within fifteen (15) days after receipt of approved periodical estimate for partial payment, there shall be paid to Contractor a sum equal to ninety-five percent (95%) of value of work performed up to last day of previous month, less aggregate of previous payments. Monthly payments shall be made only on basis of monthly estimates which shall be prepared by Contractor on a form approved by District and filed before the fifth (5th) day of month during which payment is to be made. Work completed as estimated shall be an estimate only, and no inaccuracy or error in said estimate shall operate to release Contractor or any bondsman from damages arising from such work or from enforcing each and every provision of this contract, and District shall have the right subsequently to correct any error made in any estimate for payment. Contractor shall not be entitled to have any payment estimates processed or be entitled to have any payment made for work performed so long as any lawful or proper direction concerning work, or any portion thereof given by District or Architect, shall remain uncomplied with. The final payment of five percent (5%) of the value of work done under this contract, if unencumbered, shall be made thirty-five (35) days after acceptance of work by District. Acceptance will be made only by action of the Board of Supervisors in session. Acceptance by Contractor of said final payment shall constitute a waiver of all claims against District arising from this contract. At any time after fifty percent (50%) of the work has been completed, if District, by action of its governing body, finds that satisfactory progress is being made, District may make any of the remaining payments in full on actual work completed or may withhold any amount up to five percent (5%) thereof as District may find appropriate based on the Contractor's progress.
- (b) Contractor may elect to substitute or execute an escrow agreement (in the form prescribed by the Public Contracts Code) in place of retained funds held by District pursuant to Public Contract Code section 22300.
- (c) District shall pay interest at the legal rate set forth in Code of Civil Procedure 685.010 in the event payment is not made within thirty (30) days of an undisputed properly submitted request.

Article 36. PAYMENT WITHHELD

In addition to amount which District may retain under article entitled "Payments," District may withhold a sufficient amount of amounts of any payment or payments otherwise due to Contractor, as in District's judgment may be necessary to cover:

- (a) Payments which may be past due and payable for just claims against Contractor or any subcontractors for labor or materials furnished in and about the performance of work on the project under this contract.
- (b) Defective work not remedied.
- (c) Failure of Contractor to make proper payments to subcontractors or for material or labor.

- (d) Completion of contract, if there exists a reasonable doubt that contract can be completed for balance then unpaid.
- (e) Damage to another Contractor.

When the above grounds are removed, payment shall be made for amounts withheld because of them.

District may apply such withheld amount to payment of such claims or obligations at District's discretion. In so doing, District shall be deemed the agent of Contractor, and any payment so made by District shall be considered as a payment made under contract by District to Contractor, and District shall not be liable to Contractor for such payments made in good faith. Such payments may be made without prior judicial determination of claim or obligations. District will render Contractor a proper accounting of such funds disbursed on behalf of Contractor.

Article 37. RESERVED

Article 38. DEDUCTIONS FOR UNCORRECTED WORK

If District deems it inexpedient to correct work injured or done not in accordance with contract, an equitable deduction from contract price shall be made therefore.

Article 39. PAYMENTS BY CONTRACTOR

Contractor shall pay:

- (a) For all transportation and utility services not later than the twentieth (20th) day of the calendar month following that in which such services are rendered;
- (b) For all materials, tools and other expendable equipment to the extent of ninety-five percent (95%) of cost thereof, not later than the twentieth (20th) day of the calendar month following that in which such materials, tools and equipment are delivered at site of project and balance of cost thereof not later than the thirtieth (30th) day following completion of that part of the work in or on which such materials, tools and equipment are incorporated or used; and
- (c) To each of Contractor's subcontractors, not later than the fifth (5th) day following each payment to Contractor; the respective amounts allowed Contractor on account of work performed by respective subcontractor to the extent of such subcontractor's interest therein.

Article 40. CONTRACTOR'S SUPERVISION

Unless personally present on premises where work is being done, Contractor shall keep on the work, during its progress, a competent superintendent satisfactory to District.

Contractor represents and warrants that any superintendent, employee, subcontractor and agent who will be performing any of the duties and obligations of Contractor herein possess all required licenses and authorities, as well as the experience, training, and communication skills to perform such tasks and communicate with the District and its representatives.

Superintendent shall not be changed except with consent of District unless superintendent proves to be unsatisfactory to Contractor and ceases to be in his employ.

Superintendent shall represent Contractor in Contractor's absence, and all directions given to superintendent shall be as binding as if given to Contractor. Other directions shall be so confirmed in written request in each case.

Contractor shall give efficient supervision to work, using Contractor's best skill and attention. Contractor shall carefully study and compare all drawings, specifications and other instructions, and shall at once report to Architect/Engineer any error, inconsistency or omission which Contractor may discover.

Article 41. INSPECTOR'S FIELD OFFICE

Contractor shall provide for use of District and its representative during construction working hours a temporary office of not less than seventy-five (75) square feet of floor area to be located as directed by District and its representative and to be maintained until removal is authorized by District and its representative. Office shall be of substantial waterproof construction with adequate natural light and ventilation by means of stock design windows. Door shall have a key, type walk, or padlock hasp.

A table satisfactory for study of plans and two chairs shall be provided by Contractor. Contractor shall provide and pay for adequate electric lights, local telephone service, and adequate air conditioning and heating for the field office until authorized removal.

Article 42. DOCUMENTS ON WORK

Contractor shall keep one copy of all contract documents, including addenda and change orders which are a part of contract documents, on job at all times. Said documents shall be kept in good order and available to Architect/Engineer representatives. Contractor shall be acquainted with and comply with all California Administrative Code provisions relating to this project, including, but not limited to, Title 19.

Article 43. UTILITIES AND RELOCATION

(a) All utilities, including, but not limited to, electricity, water, gas and telephone used on work, shall be furnished and paid for by Contractor. Contractor shall furnish and install necessary temporary distribution systems, including meters if necessary, from distribution points to points on site where utility is necessary to carry on the work. Upon completion of work, Contractor shall remove all temporary systems.

If contract is for addition to existing facility, Contractor may, with written permission of District, use District's existing utilities by making prearranged payments to District for utilities used by Contractor for construction.

(b) Contractor shall not be assessed damages for delay in completion of the project when such delay was caused by the failure of the awarding authority of this contract or the owner of the utility to provide for removal or relocation of the existing main or trunkline utility facilities; however, when the Contractor is aware that removal or relocation of an existing utility has not been provided for, Contractor shall promptly notify the awarding authority and the utility in writing, so that provision for such removal or relocation may be made to avoid and minimize any delay which might be caused by the failure to remove or relocate the main or trunk line utility facilities, or to provide for its removal or relocation.

In accordance with section 4215 of the Government Code, if the Contractor, while performing the contract, discovers any existing main or trunkline utility facilities not identified by the public agency in the contract plans or specifications, Contractor shall

immediately notify the public agency and utility in writing. The public utility, where they are the owner, shall have the sole discretion to perform repairs or relocation work at a reasonable price. The Contractor shall be compensated for the costs of locating and repairing damage not due to the failure of the Contractor to exercise reasonable care, and removing or relocating such utility facilities not indicated in the plans and specification with reasonable accuracy and for equipment on the project necessarily idled during such work. Such compensation shall be in accordance with the extra work provisions set out at Article 37 hereof.

Article 44. SANITARY FACILITIES

Contractor shall provide a sanitary, temporary, portable toilet facility as directed by the District and its representative for the use of all workers. The building shall be maintained in a sanitary condition at all times, and shall be left at the site until removal is directed by the District and its representative.

Article 45. TRENCHES

(a) Trenching Requirements – Four Feet (4') Below the Surface. In the event the Project involves digging trenches or other excavations that extend deeper than four feet (4') below the surface, Contractor shall:

- (1) Promptly, and before the following conditions are disturbed, notify District, in writing, of any:
 - (A) Material that Contractor believes may be material that is hazardous waste, as defined in Health & Safety Code section 25117, that is required to be removed to a Class I, Class II, or Class III disposal site in accordance with provisions of existing law;
 - (B) Subsurface or latent physical conditions at the site differing from those indicated by information about the site made available to bidders prior to the deadline for submitting bids; and
 - (C) Unknown physical conditions at the site of any unusual nature, different materially from those ordinarily encountered and generally recognized as inherent in work of the character provided for in the Agreement.
- (2) In response to any written notice generated pursuant to paragraph (a) above, District shall promptly investigate the conditions, and if it finds that the conditions do materially so differ, or do involve hazardous waste, and cause a decrease or increase in Contractor's cost of, or the time required for, performance of any part of the Work, shall issue a change order under the procedures described in paragraph 37 of the General Conditions.
- (3) In the event that a dispute arises between District and Contractor whether the conditions materially differ, or involve hazardous waste, or cause a decrease or increase in Contractor's cost of, or time required for, performance of any part of the Work, Contractor shall not be excused from any scheduled completion date provided for by this Agreement, but shall proceed with all Work to be performed under this Agreement. Contractor shall retain any and all rights provided either by contract or by law which pertain to the resolution of disputes and protests between the Parties.

- (b) Trenching Requirements – Project in Excess of Twenty-Five Thousand Dollars (\$25,000) and Five Feet (5') Below the Surface. For projects involving both an estimated expenditure in excess of twenty-five thousand dollars (\$25,000) and the excavation of any trench five feet (5') or more in depth, Contractor shall submit a detailed plan showing the design of shoring, bracing, sloping or other provisions to be made for worker protection from the hazard of caving ground during the excavation of such trench. The plan must be accepted by District (or by a registered civil or structural engineer, employed by District, to whom authority to accept has been delegated) in advance of excavation. If such plan varies from the shoring system standards, the plan shall be prepared by a registered civil or structural engineer. Nothing in this paragraph shall allow Contractor to use a shoring, sloping, or protective system less effective than that required by California Construction Safety Orders. Further, nothing in this paragraph shall be construed to impose tort liability on District or any of its employees.

Article 46. PROTECTION OF WORK AND PROPERTY

Contractor shall be responsible for all damages to persons or property that occur as a result of Contractor's fault or negligence in connection with the prosecution of this contract, and shall be responsible for the proper care and protection of all materials delivered and work performed until completion and final acceptance by District. All work shall be solely at Contractor's risk. Contractor shall adequately protect adjacent property from settlement or loss of lateral support as provided by law and contract documents. Contractor shall take all necessary precautions for safety of employees on the work, and shall comply with all applicable safety laws and building codes to prevent accidents or injury to persons on; about or adjacent to premises where work is being performed. Contractor shall erect and properly maintain, at all times, as required by conditions and progress of work, all necessary safeguards, signs, barriers, lights and watchmen for protection of workers and the public, and shall post danger signs warning against hazards created by such features in the course of construction. Contractor shall designate a responsible member of its organization on the work, whose duty shall be prevention of accidents. Name and position of person so designated shall be reported to District by Contractor.

In an emergency affecting safety of life or of work or of adjoining property, Contractor, without special instruction or authorization from District and its representative, is hereby permitted to act, at Contractor's discretion, to prevent such threatened loss or injury, and Contractor shall so act, without appeal, if so authorized or instructed by District and its representative. Any compensation claimed by Contractor on account of emergency work shall be determined by agreement.

Contractor shall provide such heat, covering, and enclosures as are necessary to protect all work, materials, equipment, appliances, and tools against damage by weather conditions. Contractor shall take adequate precautions to protect existing sidewalks, curbs, pavements, utilities, adjoining property and structures, and to avoid damage thereto, and repair any damage thereto caused by construction operations.

Contractor shall:

- (1) Enclose working area with a substantial dust reducing barrier and public safety barricade, and arrange work to cause minimum amount of inconvenience to public and District Staff in their regular business activities.

- (2) Provide substantial barricades around any shrubs or trees indicated to be preserved.
- (3) Deliver materials to building area over route designated by Architect.
- (4) When directed by District, take preventative measures to eliminate objectionable dust.
- (5) Confine Contractor's apparatus, the storage of materials, and the operations of workers to limits indicated by law, ordinances, permits or directions of Architect, and shall not unreasonably encumber premises with materials, and enforce all instructions of District and Architect regarding signs, advertising, fires, danger signals, barricades and smoking, and require that all persons employed on work comply with all regulations while on construction site. Hazardous materials of any kind are not allowed on site, without prior written approval from District.
- (6) Take care to prevent disturbing or covering any survey markers, monuments, or other devices marking property boundaries or corners. If such markers are disturbed by accident, they shall be replaced by an approved civil engineer at no cost to District.

Article 47. LAY OUT AND FIELD ENGINEERING

All field engineering required for laying out Contractor's work and establishing grades for earthwork operations shall be furnished by Contractor at Contractor's expenses. Such work shall be done by a qualified civil engineer approved by Architect/Engineer. Any required "As-Built" drawings of site development shall be prepared by the approved civil engineer.

Article 48. CUTTING AND PATCHING

Contractor shall do all cutting, fitting, or patching of work as required to make its several parts come together properly and fit it to receive or received by work of other Contractors showing upon, or reasonably implied by, the drawings and specifications for the completed structure, and Contractor shall make good after them as Architect/Engineer may direct. Contractor shall not endanger any work by cutting, excavating or otherwise altering work, and shall not cut or alter work of any other Contractor save with consent of Architect/Engineer.

Article 49. CLEANING UP

Contractor at all times shall keep premises free from debris such as waste, rubbish, and excess materials and equipment caused by work; debris shall be removed from premises. Contractor shall not leave debris under, in or about the premises. Upon completion of work, Contractor shall clean any areas where debris has collected. Contractor shall remove temporary fencing, barricades, and any temporary facilities from site.

Article 50. CORRECTION OF WORK

Contractor shall promptly remove from premises all work determined by District as failing to conform to contract, whether incorporated or not. Contractor shall promptly replace and re-execute his own work to comply with contract documents without additional expense to District, and shall bear the expense of making good all work of other Contractors destroyed or damaged by such removal or replacement.

If Contractor does not remove such work and materials within a reasonable time, fixed by written notice, District may remove the work and materials and may store the material at

Contractor's expense. If Contractor does not pay expenses of such removal within ten (10) days' time thereafter, District may liquidate such work and materials upon private sale, and shall account for net proceeds thereof, after deducting all costs and expenses that should have been borne by Contractor.

Article 51. ACCESS TO WORK

District and its representative shall at all times have access to work wherever it is in preparation or progress. Contractor shall provide safe and proper facilities for such access so that District's representative may perform their functions under contract.

Article 52. OCCUPANCY

District reserves the right to occupy buildings at any time before completion, and such occupancy shall not constitute final acceptance of any part of work covered by this contract.

Article 53. DISTRICT'S INSPECTOR

District may assign a representative to oversee work. Such representative shall have access to Inspector's Field Office and shall be fully informed of all progress and manner of work and character of materials. Representative shall have authority to stop work whenever provisions of the contract documents are not being complied with and Contractor shall instruct Contractor's employees accordingly.

All work shall be under observation of said District and its representative. Such personnel shall have free access to any or all parts of work at any time. Contractor shall furnish District and its representative reasonable facilities "Inspector's Field Office" for obtaining such information as may be necessary to keep District and its representative fully informed respecting progress and manner of work and character of materials. Inspection of work shall not relieve Contractor from any obligation to fulfill Contractor's contract. District and its representative shall have authority to stop work whenever provisions of contract documents are not being complied with, and Contractor shall instruct Contractor's employees accordingly.

Article 54. TESTS AND INSPECTIONS

If contract, District's instructions, laws, ordinances or any public authority require any work to be specially tested or approved, Contractor shall give notice in accordance with such authority of its readiness for observation or inspection at least two (2) working days prior to being tested or covered up. If inspection is by authority other than District, Contractor shall inform District of the date fixed for such inspection. Required certificates of inspection shall be secured by Contractor. Observations by District, its representative and other public authority shall be promptly made, and where practicable, at source of supply. If any work should be covered up without approval or consent of District, its representative and public authority, it must, if required by District, its representative and public authority, be uncovered for examination and satisfactorily reconstruction at Contractor's expenses in compliance with contract.

Costs of tests of any material found to be not in compliance with contract shall be paid for by Contractor.

See Comprehensive Specifications for materials to be tested.

Where such inspection and testing are to be conducted by an independent laboratory or agency, such materials or samples of materials to be tested shall be selected by such laboratory or agency or District's representative, and not by Contractor.

Contractor shall notify District a sufficient time in advance of manufacture of materials to be supplied by Contractor under contract which must by terms of contract be tested, in order that District may arrange for testing of same at source of supply. Any materials shipped by Contractor from source of supply prior to having satisfactorily passed such testing and inspection, or prior to receipt of notice from said representative that such testing and inspection will not be required, shall not be incorporated in work without prior approval of District and subsequent testing and inspection.

Re-examination of questioned work may be ordered by District, and, if so ordered, work must be uncovered by Contractor. If such work be found in accordance with contract documents, District shall pay costs of re-examination and replacement. If such work be found not in accordance with contract documents, Contractor shall pay such costs.

Article 55. SOILS INVESTIGATION REPORT

When a soils investigation report obtained from test holes in site is available, such report shall not be part of this contract. Any information obtained from such report or any information given on drawings as to subsurface soil condition or to elevations of existing grades or elevations of underlying rock is approximate only and is not guaranteed, and does not form a part of the contract. Contractor is required to make a visual examination of site, and must make whatever tests Contractor deems appropriate to determine underground condition of soil. Contractor agrees that it will make no claim against District for damages in the event that, during progress of the work, Contractor encounters subsurface or latent conditions at site materially differing from those shown on drawings or indicated in specifications, or for unknown conditions of an unusual nature which differ materially from those ordinarily encountered and generally recognized as inherent in the work of the character provided for in plans and specifications.

Article 56. ARCHITECT/ENGINEER'S AND CONSTRUCTION MANAGER'S STATUS

The construction manager shall be District's representative during the construction period, and shall observe the progress and quality of the work on behalf of District. The construction manager shall have the authority to act on behalf of District only to the extent expressly provided in the contract documents. The construction manager shall have authority to stop work whenever such stoppage may be necessary in construction manager's reasonable opinion to insure the proper execution of the contracts.

The Architect/Engineer shall be, in the first instance, the judge of compliance with the design intent of the contract documents.

Article 57. RESERVED

Article 58. PROVISIONS REQUIRED BY LAW DEEMED INSERTED

Each and every provision of law and clause required by law to be inserted in the contract shall be deemed to be inserted herein, and the contract shall be read and enforced as though it were included herein, and if, through mistake or otherwise, any such provision is not inserted, or is not correctly inserted, then upon application of either party, the contract shall forthwith be physically amended to make such insertion or correction.

Article 59. LABOR - EMPLOYMENT SAFETY

Contractor shall maintain emergency first aid treatment for Contractor's employees which complies with the Federal Occupational Safety and Health Act of 1970 (29 U.S.C.A. 651, *et seq.*).

Article 60. NOTICE OF TAXABLE POSSESSORY INTEREST

The terms of this document may result in the creation of a possessory interest. If such a possessory interest is vested in a private party to this document, the private party may be subjected to the payment of personal property taxes levied on such interest.

Article 61. ASSIGNMENT OF UNFAIR BUSINESS PRACTICES CLAIMS (CLAYTON ACT AND CARTWRIGHT ACT)

Bidder shall comply with the following:

"In entering into a public works contract or a subcontract to supply goods, services or materials pursuant to a public works contract, the contractor or subcontractor offers and agrees to assign to the awarding body all rights, title and interest in and to all causes of action it may have under Section 4 of the Clayton Act (15 U.S.C. sec. 15) or under the Cartwright Act (Chapter 2 commencing with Section 16700) of Part 2 of Division 7 of the Business and Professions Code), arising from purchases of goods, services, or materials pursuant to the public works contract or the subcontract. This assignment shall be made and become effective at the time the awarding body tenders final payment to the contractor, without further acknowledgment by the parties." Cal Pub Contract Code § 7103.5(b)

Article 62. SUBSTITUTION OF SECURITY

Upon Contractor's request, District will make payment of funds withheld from progress payments to ensure performance under the contract pursuant to the requirements of California Public Contracts Code, section 22300, if the Contractor deposits in escrow with District, or with a bank acceptable to District, securities eligible for investment under Government Code section 16430 or bank savings and loan certificates of deposit, subject to the following conditions:

- (a) Contractor shall bear the expense of District and the escrow agent, and District and the bank, in connection with the escrow deposit made.
- (b) Securities or certificates of deposit to be placed in escrow shall be of a value at least equivalent to the amount of retention to be paid to the Contractor pursuant to this Article.
- (c) Contractor shall enter into an escrow agreement satisfactory to District, which agreement shall include provisions governing, inter alia:
 - (1) the amount of securities to be deposited,
 - (2) the providing of powers of attorney or other documents necessary for the transfer of the securities to be deposited,
 - (3) conversion of cash to provide funds to meet defaults by Contractor including, but not limited to, termination of Contractor's control over the work, stop notice filed pursuant to law or other amounts to be kept or retained under the provisions of the contract,

- (4) decrease in value of securities on deposit,
 - (5) the termination of the escrow upon completion of the contract.
- (d) Contractor shall obtain the written consent of the surety to such agreement.

Article 63. NON-DISCRIMINATION AND DISADVANTAGED BUSINESS ENTERPRISE PROGRAM

- (a) During the performance of this Agreement, Contractor and its subcontractors shall not unlawfully discriminate, harass or allow harassment against any employee or applicant for employment because of sex, race, color, ancestry, religious creed, national origin, physical disability (including HIV and AIDS), mental disability, medical condition (cancer), age (over forty (40)), marital status and denial of family care leave. Contractor and its subcontractors shall insure that the evaluation and treatment of their employees and applicants for employment are free from such discrimination and harassment. Contractor and its subcontractors shall comply with the provisions of the Fair Employment and Housing Act (Gov. Code section 12990 (a-f) *et seq.*) and the applicable regulations promulgated thereunder (California Code of Regulations, Title 2, Section 7285 *et seq.*). The applicable regulations of the Fair Employment and Housing Commission implementing Government Code section 12990 (a-f), set forth in Chapter 5 of Division 4 of Title 2 of the California Code of Regulations, are incorporated into this Agreement by reference and made a part hereof as if set forth in full. The applicable regulations of Section 504 of the Rehabilitation Act of 1973 (29 U.S.C. section 794 (a)) are incorporated into this Agreement by reference and made a part hereof as if set forth in full. Contractor and its subcontractors shall give written notice of their obligations under this clause to labor organizations with which they have a collective bargaining or other agreement. Contractor shall include the nondiscrimination and compliance provisions of this clause in all subcontracts to perform Work under this Agreement.
- (b) Contractor and its subcontractors shall reference and abide by the guidance and Disadvantaged Business Enterprise specifications contained in the California Department of Transportation's Local Programs Procedures 06-01 (which has been approved and released at <http://www.dot.ca.gov/> when working pursuant to this Agreement.

Article 64. SPECIAL CONDITIONS

- (a) The work shall be commenced on the date stated in District's *Notice to the Contractor to Proceed* which date will not be greater than ten (10) consecutive calendar days from and after the date of execution of the contract, and shall be completed within **ninety (90) working** days from and after the date stated in such notice. (See Article 2 of *Agreement* and Article 6 of *General Conditions*.)
- (b) The number of copies of drawings and specifications to be furnished to Contractor free of charge, per Article 3 of the *General Conditions* is three (3).
- (c) The number of executed copies of the *Agreement*, the *Performance Bond*, and the *Payment Bond* for the *Public Works* required is six (6).

Article 65. CONTRACT CONSTRUCTION

This contract has been reviewed by legal counsel for both District and Contractor, and no presumption or rule that ambiguities shall be construed against the drafting party shall

apply to the interpretation or enforcement of this contract and/or any and all amendments thereto.

Article 66. COGNIZANCE OF VIOLATIONS BY District

- (a) Contractor understands and agrees that District shall take cognizance of violations of Chapter 1 of Part 7 of Division 2 of the California Labor Code committed in the course of the execution of this Agreement, and shall promptly report any suspected violations to the Labor Commissioner.
- (b) If District determines as a result of its own investigation that there has been a violation of Chapter 1 of Part 7 of Division 2 of the California Labor Code and withholds payment to Contractor, the procedures in California Labor Code section 1771.6 shall be followed.
- (c) District may bring an action in a court of competent jurisdiction to recover from Contractor the difference between the wages actually paid to an employee and the wages that were required to be paid to an employee pursuant to Chapter 1 of Part 7 of Division 2 of the California Labor Code, any penalties required to be paid pursuant to Chapter 1 of Part 7 of Division 2 of the California Labor Code, and costs and attorney's fees related to the action, if either of the following is true:
 - (1) District previously affirmatively represented to Contractor in writing, in the call for bids, or otherwise, that the Work was not a "public work," as defined in Chapter 1 of Part 7 of Division 2 of the California Labor Code; or
 - (2) District received actual written notice from the Department of Industrial Relations that the Work is a "public work," as defined in Chapter 1 of Part 7 of Division 2 of the California Labor Code, and failed to disclose that information to Contractor before the bid opening or award.

Article 67. LABOR STANDARDS COMPLIANCE REQUIREMENTS

- (a) It is Contractor's responsibility to provide all labor compliance documentation from its subcontractors completely and accurately in a timely manner. Contractor is responsible to review promptly and then forward on all required documentation to District per the time schedules in the Labor Compliance Handout. Included with the Labor Compliance Handout, District will provide training, documentation requirements, forms, etc., at the preconstruction conference or at a time designated by District.

For those Public Works Projects that are subject to the State Department of Industrial Relations (DIR), Division of Labor Standards Enforcement (DLSE) compliance monitoring and enforcement it is the Contractor's responsibility to submit certified payroll records directly to the state Compliance Monitoring Unit (CMU). More information concerning state compliance can be found at <https://www.dir.ca.gov/Public-Works/publicworks.html>. The responsibility for compliance with these provisions is fixed with the Contractor.

- (b) In the event, during the review process of labor compliance documentation from District's labor compliance monitor, inaccurate, missing or incomplete information was provided, the labor compliance monitor will request from Contractor the items, revisions and documentation needed. The cost of this additional labor compliance enforcement shall be borne by Contractor.

Article 68. CONFLICT OF INTEREST AND GRATUITIES

- (a) Contractor agrees that it presently has no interest and shall not acquire any interest, direct or indirect, which could conflict in any manner or degree with the performance of services required to be performed under this Agreement. Contractor further agrees that in the performance of this Agreement, no person having any such interest shall be employed.
- (b) Contractor agrees to designate such person or persons who have responsibility for carrying out the services under this Agreement and that such person or persons as may be designated shall take any and all actions necessary to comply with District's Conflict of Interest Code adopted pursuant to California Government Code section 81000 to the extent required thereunder.
- (c) If it is found, after notice and hearing by District, that gratuities (in the form of entertainment, gifts, or otherwise) were offered or given by Contractor, or any agent or representative of Contractor, to any officer, employee or agent of District with a view toward securing a contract or securing favorable treatment with respect to the awarding or amending or the making of any determinations with respect to the performance of this Agreement, District may, by written notice to Contractor, terminate the right of Contractor to proceed under this Agreement and/or may pursue such other rights and remedies provided by law or under this Agreement.
- (d) In the event this Agreement is terminated as provided herein, District shall be entitled (1) to pursue the same remedies against Contractor as it could pursue in the event of a breach of the Agreement by Contractor, and (2) as a penalty in addition to any other damages to which it may be entitled by law, to exemplary damages in an amount (as determined by District) which shall be not less than three (3) nor more than ten (10) times the costs incurred by Contractor in providing any such gratuities to any such officer, employee or agent.

Article 69. FEDERAL CONTRACT REQUIREMENTS

(a) Signage Requirements.

- (1) Project Identity Signage. Contractor is required to provide and install the required project identity signage as detailed in the Plans and Specifications, in the size and at the location indicated by the Director of Public Works or his/her designee, and to maintain the signage in good condition for the duration of the Project. The signage may not be removed until the Notice of Completion is recorded or by written direction of the Director of Public Works or his/her designee.
- (2) Required Employee Signage and Posters. Contractor is required to provide and install the Federal and State required employee posters and the required material pertaining to the required labor standards provisions are posted (including, but not limited to, WH-1321, OSHA 3165 and OFCCP-English, EFCCP-Spanish) at the worksite in a prominent and accessible place.
- (3) Section 3 Compliant Signage. If required by District, Contractor is directed to provide and install the "Offer for Employment" signage as detailed in the Plans and Specifications in the size and at the location indicated by the Director of

Public Works or his/her designee and to maintain the signage in good condition for the duration of the Project. The signage may not be removed until the Notice of Completion is recorded or by written direction of the Director of Public Works or his/her designee.

- (b) Housing And Urban Development Act Compliance. When applicable, Contractor agrees to comply with Section 3 of the Housing and Urban Development Act of 1968 (42 U.S.C. 3601 *et seq.*) which provides that to the greatest extent feasible, Contractor shall provide job training, employment and contracting opportunities for low- or very low income residents in connection with the Project. The responsibility for compliance with these provisions is fixed with Contractor.
- (c) Copeland “Anti-Kickback” Act Compliance. When applicable, Contractor agrees to comply with the Copeland Act (18 USC §874 and 40 USC §276c; 29 CFR Part 3) which precludes Contractor and its subcontractors from in any way inducing an employee to give up any part of the compensation to which he or she is entitled under his or her contract of employment. Contractor and its subcontractors shall submit a weekly statement of the wages paid to each employee performing on covered work during the preceding payroll period. Contractor understands and agrees that should Contractor its subcontractors induce an employee working on a covered contract to give up any part of the compensation to which he or she is entitled, the inducing party may be subject to a five thousand dollar (\$5,000) fine, or imprisonment for up to five (5) years, or both. Contractor also understands and agrees that willful falsification of the statement of compliance may subject the employer to civil or criminal prosecution and may be cause for contract termination or debarment. The responsibility for compliance with these provisions is fixed with Contractor.
- (d) Fair Labor Standards Act Compliance. When applicable, Contractor agrees to comply with the Fair Labor Standards Act of 1938 as amended (29 U.S.C. 201 *et seq.*) which establishes minimum wage, overtime pay, recordkeeping, and youth employment standards affecting full-time and part-time workers on the Project. The responsibility for compliance with these provisions is fixed with Contractor.
- (e) Certification Regarding Debarment, Suspension and Other Responsibility Matters. When applicable, Contractor agrees to execute a certification regarding debarment, suspension and other responsibility matters. The responsibility for compliance with this provision is fixed with Contractor.
- (f) Federal Equal Employment Opportunity Construction Contract Specifications. When applicable, Contractor agrees to incorporate the notice set forth in paragraph (d) of 41 C.F.R. 60-4.2 relating to the “Equal Opportunity Clause” and the “Standard Federal Equal Employment Specifications.” The responsibility for compliance with this provision is fixed with Contractor.
- (g) Clean Air Act and the Federal Water Pollution Control Act. When applicable, Contractor agrees to comply with all applicable standards, orders or regulations issued pursuant to the Clean Air Act (42 U.S.C. 7401 *et seq.*), the Federal Water Pollution Control Act as amended (33 U.S.C. 1251 *et seq.*), Presidential Executive Order 11738 and Environmental Protection Agency regulations set forth at 40 C.F.R. Part 15. Contractor understands and agrees that violations shall be reported to the

Federal awarding agency and the Regional Office of the Environmental Protection Agency. The responsibility for compliance with these provisions is fixed with Contractor.

- (h) Prohibition on the Use of Federal Funds for Lobbying. When applicable, Contractor shall file the required certification. Each tier certifies to the tier above that it will not and has not used Federal appropriated funds to pay any person or organization for influencing or attempting to influence an officer or employee of any agency, a member of Congress, officer or employee of Congress, or an employee of a member of Congress in connection with obtaining any Federal contract, grant or any other award covered by 31 U.S.C. 1352. Each tier shall also disclose any lobbying with non-Federal funds that takes place in connection with obtaining any Federal award. Such disclosures are forwarded from tier to tier up to the recipient. The responsibility for compliance with this provision is fixed with Contractor.
- (i) Federal Employment Eligibility Verification. Contractor shall verify name, date of birth and social security number, along with immigration information for non-citizens in order to verify the identity and employment eligibility of both citizen and non-citizen new hires. The responsibility for compliance with this provision is fixed with Contractor.
- (j) The Civil Rights, HCD and Age Discrimination Act Assurances. During the performance of this Agreement, Contractor assures that no otherwise qualified person shall be excluded from participation or employment, denied program benefits or be subjected to discrimination based on race, color, national origin, gender, age or handicap, under any program or activity funded by this Agreement, as required by Title VI of the Civil Rights Act of 1964, Title I of the Housing and Community Development Act of 1974, as amended, and the Age Discrimination Act of 1975, and all implementing regulations. The responsibility for compliance with these provisions is fixed with Contractor.
- (k) Standard Equal Opportunity Clause.
 - (1) Contractor hereby agrees that it will incorporate or cause to be incorporated into any contract for construction work, or modification thereof, as defined in the regulations of the Secretary of Labor at 41 CFR Chapter 60, which is paid for in whole or in part with funds obtained from the Federal Government or borrowed on the credit of the Federal Government pursuant to a grant, contract, loan insurance, or guarantee, or undertaken pursuant to any Federal program involving such grant, contract, loan, insurance, or guarantee, the following equal opportunity clause:

“During the performance of this contract, the Contractor agrees as follows:

- (A) The Contractor will not discriminate against any employee or applicant for employment because of race, color, religion, sex, national origin or disabilities. The Contractor will take affirmative action to ensure that applicants are employed, and that employees are treated during employment without regard to their race, color, religion, sex, or national origin. Such action shall include, but not be limited to, the following: employment, upgrading, demotion or transfer; recruitment or recruitment advertising; layoff or termination; rates of pay or other forms of

compensation; and selection for training, including apprenticeship. The Contractor agrees to post in conspicuous places, available to employees and applicants for employment, notices to be provided setting forth the provisions of this nondiscrimination clause.

- (B) The Contractor will, in all solicitations or advertisements for employees placed by or on behalf of the Contractor, state that all qualified applicants will receive consideration for employment without regard to race, color, religion, sex, national origin or disabilities.
- (C) The Contractor will send to each labor union or representative of workers with which the Contractor has a collective bargaining agreement or other contract or understanding, a notice to be provided advising the said labor union or workers' representatives of the Contractor's commitments under this section, and shall post copies of the notice in conspicuous places available to employees and applicants for employment.
- (D) The Contractor will comply with all provisions of Executive Order 11246 of September 24, 1965, and of the rules, regulations, and relevant orders of the Secretary of Labor.
- (E) The Contractor will furnish all information and reports required by Executive Order 11246 of September 24, 1965, and by rules, regulations, and orders of the Secretary of Labor, or pursuant thereto, and will permit access to its books, records, and accounts by the administering agency and the Secretary of Labor for purposes of investigation to ascertain compliance with such rules, regulations, and orders.
- (F) In the event of the Contractor's noncompliance with the discrimination clauses of this contract or with any of the said rules, regulations, or orders, this contract may be canceled, terminated, or suspended in whole or in part and the Contractor may be declared ineligible for further government contracts or federally assisted construction contracts in accordance with procedures authorized in Executive Order 11246 of September 24, 1965, and such other sanctions may be imposed and remedies invoked as provided in Executive Order 11246 of September 24, 1965, or by rules, regulations, or orders of the Secretary of Labor, or as otherwise provided by law.
- (G) The Contractor will include the portion of the sentence immediately preceding paragraph "1" and the provisions of paragraphs "1" through "7" in every contract or purchase order unless exempted by rules, regulations, or orders of the Secretary of Labor issued pursuant to Section 504 of Executive Order 11246 of September 24, 1965, so that such provisions will be binding upon each contractor or vendor. The Contractor will take such action with respect to any contract or purchase order as the administering agency may direct as a means of enforcing such provisions, including sanctions for noncompliance; provided, however, that in the event a Contractor becomes involved in, or is threatened with, litigation with a contractor or vendor as a result of such direction by the administering agency, the Contractor may request the

United States to enter into such litigation to protect the interests of the United States.”

- (1) Contractor further agrees that it will be bound by the above equal opportunity clause with respect to its own employment practices when it participates in federally-assisted construction work; provided that if Contractor so participating is a State or local government, the above equal opportunity clause is not applicable to any agency, instrumentality, or subdivision of such government which does not participate in work on or under the Agreement.
- (2) Contractor agrees that it will assist and cooperate actively with the administering agency and the Secretary of Labor in obtaining the compliance of Contractors and subcontractors with the equal opportunity clause and the rules, regulations, and relevant orders of the Secretary of Labor, that it will furnish the Department and HUD and the Secretary of Labor such information as they may require for the supervision of such compliance, and that it will otherwise assist the administering agency in the discharge of the agency’s primary responsibility for securing compliance.
- (3) Contractor further agrees that it will refrain from entering into any contract or contract modification subject to Executive Order 11246 of September 24, 1965, with a contractor debarred from, or who has not demonstrated eligibility for, government contracts and federally-assisted construction contracts, pursuant to the Executive Order and will carry out such sanctions and penalties for violation of the equal opportunity clause as may be imposed upon contractors and subcontractors by the administering agency or the Secretary of Labor pursuant to Part II, Subpart D of the Executive Order. In addition, Contractor agrees that if it fails or refuses to comply with these undertakings, District may take any or all of the following actions:

Cancel, terminate, or suspend in whole or in part this funding commitment (contract, loan, grant, insurance, guarantee); refrain from extending any further assistance to the applicant under the program with respect to which the failure or refund occurred until satisfactory assurance of future compliance has been received from such Contractor; and refer the case to the Department of Justice for appropriate legal proceedings.

Article 70. INELIGIBILITY

If the Bidder has been deemed ineligible to perform work on public works projects pursuant to Labor Code Sections 1777.1 or 1777.7, then it shall be prohibited from bidding on, being awarded a contract for, or performing work as a subcontractor on this project, or any other public works project within the state of California.

Article 71. RESOLUTION OF CLAIMS

- (a) Compliance with all change order procedures is a prerequisite to filing a Public Contract Code Claim pursuant to this Section. Claims must be submitted no later than (a) 30 days after the dispute resolution process set forth in Section 5-1.43 is complete or (b) 30 days after the occurrence of the event giving rise to the claim.

- (b) In accordance with the procedures set forth in Public Contract Code Sections 9204 and 20104-20104.6, a Contractor may submit a claim by registered or certified mail with return receipt requested for one or more of the following: (a) a time extension, including, without limitation, for relief from damages or penalties for delay assessed by the District; (b) payment by the District of money or damages arising from work done by, or on behalf of, the Contractor pursuant to this contract and payment for which is not otherwise expressly provided or to which the Contractor is not otherwise entitled; or (c) payment of an amount that is disputed by the District.
- (c) The Contractor shall furnish reasonable documentation to support the claim, including, but not limited to: 1) a clear concise recital of the basis upon which the claim is asserted, including a designation of the provisions of the Contract upon which the claim is based. 2) a statement as to the amount of time and/or compensation sought pursuant to the claim; 3) whether the Contractor's claim arises from an ongoing occurrence, and if so a description of the specific work activities affected by the claim, 4) a time impact analysis in the event that Contractor request a time extension, 5) full and complete cost records supporting the amount of any claim for additional compensation, and 6) a notarized certification by the Contractor as follows: "Under the penalty of law for perjury or falsification and with specific reference to the California False Claims Act. Government Code Section 12650 et seq. The undersigned hereby certifies that the information contained herein is a true, accurate and complete statement of all features relating to the claim asserted." Failure by the Contractor to provide sufficient documentation will result in denial of the claim. The District reserves the right to request additional documentation, or clarification of the documentation provided.
- (d) Upon receipt of a claim, the District will conduct a reasonable review and provide a written statement to the Contractor identifying what portion of the claim is disputed and what portion is undisputed within 45 days of receipt of the claim. The District and Contractor may, by mutual agreement, extend the 45 day time period. For any undisputed portion of a claim, the District must make payment within 60 days of its issuance of the written statement.
- (e) If the Contractor disputes the District's written statement, or if the District fails to respond, the Contractor may demand an informal conference to meet and confer for the settlement of the issues in dispute. The District will then schedule the meet and confer conference within 30 days of the demand. Within 10 business days following the meet and confer conference. The District will provide a written statement identifying the portion of the claim that remain in dispute. Any payment due on an undisputed portion of the claim will be made within 60 days of the meet and confer conference.
- (f) After the meet and confer conference, any disputed portion of the claim shall be submitted to non-binding mediation. Alternatively, upon receipt of a claim, the parties may mutually agree to waive in writing, mediation and proceed directly to the commencement of a civil action or binding arbitration as applicable, if mediation is unsuccessful, the parts of the claim that remain in dispute shall be subject to applicable procedures set forth below.

- (g) Failure of a public entity to respond to a claim within the time periods described above shall result in the claim being deemed rejected in its entirety. Additionally amounts not paid in a timely manner shall bear interest at 7 percent per year.
- (h) In the event that the mediation is unsuccessful, Contractor must file a government claim pursuant to Government Code Sections 910 et seq. in order to initiate a civil action.
- (i) In any civil action filed to resolve claims, the court shall submit the matter to nonbinding mediation within 60 days following the filing or responsive pleading provided that the parties have not already participated in mediation of the claim as outlined above. If the matter remains in dispute after nonbinding mediation, the court shall submit the matter to judicial arbitration pursuant to the Code of Civil Procedure Section 1141.10 et. seg. If the matter remains in dispute after judicial arbitration, the District or the Contractor may request a trial de novo.

Article 72. MISCELLANEOUS

- (a) Entire Agreement. This Agreement contains the entire agreement between District and Contractor relating to the transactions contemplated hereby and supersedes all prior or contemporaneous agreements, understandings, provisions, negotiations, representations, or statements, either written or verbal.
- (b) Assignment. Neither this Agreement nor any duties or obligations hereunder shall be assignable by Contractor without the prior written consent of District.
- (c) Modification. No modification, waiver, amendment, discharge, or change of this Agreement shall be valid unless the same is in writing and signed by the Party against whom the enforcement of such modification, waiver, amendment, discharge, or change is or may be sought.
- (d) Captions. Captions in this Agreement are inserted for convenience of reference only and do not define, describe, or limit the scope or the intent of this Agreement or any of the terms thereof.
- (e) Partial Invalidity. If any provision in this Agreement is held by a court of competent jurisdiction to be invalid, void, or unenforceable, the remaining provisions will nevertheless continue in full force without being impaired or invalidated in any way.
- (f) Gender and Interpretation of Terms and Provisions. As used in this Agreement and whenever required by the context thereof, each number, both singular and plural, shall include all numbers, and each gender shall include a gender. Contractor as used in this Agreement or in any other document referred to in or made a part of this Agreement shall likewise include singular and the plural, a corporation, a partnership, individual, firm, or person acting in any fiduciary capacity as executor, administrator, trustee or in any other representative capacity or any other entity. All covenants herein contained on the part of Contractor shall be joint and several if more than one person, firm or entity executes this Agreement.
- (g) Waiver. No waiver of any breach or of any of the covenants or conditions of this Agreement shall be construed to be a waiver of any other breach or to be consent to any further or succeeding breach of the same or any other covenant or condition.

- (h) Attorneys' Fees and Costs. If either Party herein brings an action to enforce the terms thereof or to declare rights hereunder, the prevailing Party in any such action, on trial or appeal, shall be entitled to reasonable attorneys' fees as fixed by the court and actual costs to be paid by the losing Party.
- (i) Authority.
 - (1) Each individual executing this Agreement on behalf of Contractor represents and warrants that:
 - (A) He/She is duly authorized to execute and deliver this Agreement on behalf of Contractor;
 - (B) Such execution and delivery is in accordance with the terms of the Articles of Incorporation or Partnership, any by-laws or Resolutions of Contractor and;
 - (C) This Agreement is binding upon Contractor in accordance with its terms.
 - (2) Contractor shall deliver to District evidence acceptable to District of the foregoing within thirty days of execution of this Agreement.
- (j) Counterparts. This Agreement may be executed in counterparts.
- (k) Review of Agreement Terms. This Agreement has been reviewed and revised by legal counsel for both District and Contractor, and no presumption or rule that ambiguities shall be construed against the drafting Party shall apply to the interpretation or enforcement of the same or any subsequent amendments thereto.

EXHIBIT A - GENERAL SPECIFICATIONS

SALTON CITY PARK RESTROOM IMPROVEMENTS 2208-2210 IRIDESCENT DRIVE, THERMAL, CA 92274

DISTRICT PROJECT NO. SCP-1

LAWS AND REGULATIONS

Contractor shall comply with all applicable and current local, state, and federal laws, guidelines, standards, and California building codes.

SCHEDULE

Monday to Friday between 7:00 AM to 4:00 PM per Article 19. Hours of Work

PROJECT DESCRIPTION

The project consists of landscape and irrigation installation and all other facilities and incidentals necessary to complete the improvements as required by the project specifications, and other provisions of the contract. All the above improvements are to be constructed in a workmanlike manner, leaving the entire project in a neat and presentable condition. Refer to Section 4000 for more information.

UNDERGROUND FACILITIES

The contractor is responsible for coordinating all project documentation, including but not necessarily limited to, the Contract Documents and existing record drawings for the determination of the location of all underground facilities.

The Contractor shall exercise care in all excavations to avoid damage to existing underground facilities. This shall include potholing or hand digging in those areas where underground facilities are known to exist until they have been sufficiently located to avoid damage to the facilities.

Prior to fabrication, the Contractor shall verify the location and elevations of existing underground facilities, which the Contractor is connecting to.

No additional compensation shall be provided to the Contractor for compliance with the provisions of this section or for the damage.

SHEET SPECIFICATIONS

All project specifications are provided as sheet specifications and are incorporated within the Architectural plan set. Refer to the Architectural drawings and associated notes for all applicable specifications, requirements, materials, and installation criteria related to this work.

EXHIBIT B – SAMPLE AGREEMENT FOR SERVICES

**SALTON COMMUNITY SERVICES DISTRICT
SALTON CITY PARK
RESTROOM IMPROVEMENTS
2208-2210 IRIDESCENT DRIVE, THERMAL, CA 92274**

DISTRICT PROJECT NO. SCP-1

SAMPLE

AGREEMENT FOR CONSTRUCTION SERVICES

THIS AGREEMENT FOR CONSTRUCTION SERVICES (“Agreement”), made and entered into effective the ____ day of _____, 2026, by and between the SALTON COMMUNITY SERVICES DISTRICT, a California Special District of the State of California, (“District”) and «Contractor_Business_Name», a «Contractor_Business_Type» licensed to do business within the state of California (“Contractor”) (individually, “Party;” collectively, “Parties”) shall be as follows:

RECITALS

WHEREAS, District desires to retain a qualified individual, firm or business entity to provide professional construction services for District Project Number «Project_Number», «Project_Name» (“Project”); and WHEREAS, District wishes to engage Contractor for performance of such services as are provided for herein and Contractor is willing to accept such engagement.

NOW, THEREFORE , District and Contractor have and hereby agree to the following:

1. DEFINITIONS

- 1.1. “Invitation for Bid” shall mean the document entitled, “«Name_of_RFP»,” dated «Date_of_RFP», which includes all special notices, addendums, exhibits and Plans and Specifications as defined in Paragraph 1.3. The Invitation for Bid is attached hereto as Exhibit “A” and incorporated herein as though fully set forth.
- 1.2. “Proposal” shall mean Contractor’s document entitled “«Name_of_Proposal»,” dated «Date_of_Proposal» and submitted to the Clerk of the Board. The Proposal is attached hereto as Exhibit “B” and incorporated herein as though fully set forth.
- 1.3. “Plans and Specifications” shall mean the plans and specifications approved by the General Manager, or his/her designee, for Project Number «Project_Number». While District is responsible for the completeness and accuracy of the Plans and Specifications for the Project, Contractor is required to review the Plans and Specifications and promptly report any errors or omissions to District.

2. CONTRACT COORDINATION

- 2.1. The General Manager or his/her designee shall be the representative of District for all purposes under this Agreement. The General Manager or his/her designee is hereby designated as the Contract Manager for District. He/she shall supervise the progress and execution of this Agreement.
- 2.2. Contractor shall assign a single Contract Manager to have overall responsibility for the progress and execution of this Agreement. Should circumstances or conditions subsequent to the execution of this Agreement require a substitute Contract Manager for any reason, the Contract Manager designee shall be subject to the prior written acceptance and approval of District’s Contract Manager.

3. SCOPE OF WORK TO BE PERFORMED BY CONTRACTOR

- 3.1. Contractor shall furnish all work, labor, tools, equipment, materials, supervision, scheduling, coordination and contract administration necessary to construct and complete the Project in a good, expeditious, workman-like and substantial manner under the terms of and in full and complete compliance with this Agreement (“Work”).
- 3.2. Contractor shall comply with and perform work consistent with all terms, conditions and requirements of the Plans, Specifications, the Invitation for Bids and this Agreement.
- 3.3. All described work shall be constructed, installed, placed and performed in conformance with the Plans and Specifications and all Special Provisions contained therein and as directed by District’s engineer.
- 3.4. In the event of a conflict among this Agreement, the Invitation for Bid and the Proposal, the Invitation for Bid shall take precedence over the Proposal and this Agreement shall take precedence over both.
- 3.5. Contractor shall perform such other tasks as necessary and proper for the full performance of the obligations assumed by Contractor hereunder; including but not limited to any additional work or change orders agreed upon pursuant to written authorization as described in Section 5. Proposed additional work or change order requests, when applicable, will be attached and incorporated herein under Exhibit “B” (as “B-1,” “B-2,” etc.).

4. TRENCHING REQUIREMENTS AND UTILITY RELOCATION

- 4.1. Four Feet (4’) Below the Surface. In the event the Project involves digging trenches or other excavations that extend deeper than four feet (4’) below the surface, Contractor shall:
 - 4.1.1. Promptly, and before the following conditions are disturbed, notify District, in writing, of any:
 - a) Material that Contractor believes may be material that is hazardous waste, as defined in Health & Safety Code §25117, that is required to be removed to a Class I, Class II or Class III disposal site in accordance with provisions of existing law;
 - b) Subsurface or latent physical conditions at the site differing from those indicated by information about the site made available to bidders prior to the deadline for submitting bids; and
 - c) Unknown physical conditions at the site of any unusual nature, different materially from those ordinarily encountered and generally recognized as inherent in work of the character provided for in the Agreement.
 - 4.1.2. In response to any written notice generated pursuant to Subparagraph 4.1.1, District shall promptly investigate the conditions, and if it finds that the conditions do materially so differ, or do involve hazardous waste, and cause a decrease or increase in Contractor’s cost of, or the time required for, performance of any part of the Work, District shall issue a change order under the procedures described in this Agreement.

- 4.1.3. In the event that a dispute arises between District and Contractor whether the conditions materially differ, or involve hazardous waste, or cause a decrease or increase in Contractor's cost of, or time required for, performance of any part of the Work, Contractor shall not be excused from any scheduled completion date provided for by this Agreement, but shall proceed with all Work to be performed under this Agreement. Contractor shall retain any and all rights provided either by contract or by law which pertain to the resolution of disputes and protests between the Parties.
- 4.2. Trenching Requirements – Project in Excess of Twenty-Five Thousand Dollars (\$25,000) and Five Feet (5') Below the Surface. For projects involving both an estimated expenditure in excess of twenty-five thousand dollars (\$25,000) and the excavation of any trench five feet (5') or more in depth, Contractor shall submit a detailed plan showing the design of shoring, bracing, sloping or other provisions to be made for worker protection from the hazard of caving ground during the excavation of such trench. The plan must be accepted by District (or by a registered civil or structural engineer, employed by District, to whom authority to accept has been delegated) in advance of excavation. If such plan varies from the shoring system standards, the plan shall be prepared by a registered civil or structural engineer. Nothing in this Paragraph shall allow Contractor to use a shoring, sloping, or protective system less effective than that required by California Construction Safety Orders. Further, nothing in this Paragraph shall be construed to impose tort liability on District or any of its employees.
- 4.3. Utilities Relocation. In the event that Contractor, in the scope of work, encounters utilities not shown on District's plans, District shall compensate Contractor for utilities relocation work. District shall also waive liquidated damages for any delay that occurs as a result of said encounter and/or relocation of utilities.

5. CHANGE ORDERS

- 5.1. Change Orders. Contractor shall make no changes to the Work to be performed pursuant to this Agreement, including but not limited to additions, deletions, modifications or substitutions, nor shall Contractor perform any extra work (collectively, "Change Order Work") without the prior written consent of District. If Contractor encounters conditions it considers different from those described in Exhibit "A" to this Agreement, Contractor may request a change order in conformance with District's standard procedure ("Change Order"). If District approves the request, Contractor will execute a Change Order and Contractor's execution of the Change Order shall confirm approval thereof. District may order additional work, and Contractor shall perform such changes in the Work as directed by District in any Change Order prepared by Contractor. District's rights to eliminate portions of the Work or to initiate a Change Order shall not be limited in any way. The Change Order shall be in writing and shall include:
 - 5.1.1. Any and all supporting documents and drawings depicting the source and location of the desired change, and explain in detail the field conditions and reasons for the requested change;
 - 5.1.2. Any change or adjustment to the compensation set forth in this Agreement as a result of changes in the Work based on a lump sum or time and material basis, as may be directed by District; and

5.1.3. Any request for adjustments to time for completion of the Project.

- 5.2. Payment for Change Order Work. Contractor shall not be entitled to receive any compensation for work, labor, materials or changes of any kind, regardless of whether ordered by District or any of its representatives, unless a Change Order has been submitted in writing and approved prior to the commencement of any Change Order Work as described above. If the changes are required by any inspecting governmental agencies or utility companies, or are otherwise required to comply with any codes, laws, rules or regulations, including those set forth in this Agreement, then Contractor shall not be entitled to any increases in the compensation set forth in this Agreement or other compensation as a result of the changes.
- 5.3. Disputed Change Order Work. Any dispute concerning the performance of such Change Order Work or the amount of compensation to be paid to Contractor by District shall not affect Contractor's obligation to perform such Change Order Work. Contractor agrees that it shall timely complete all Change Order Work even if there shall be a dispute between Contractor and District over the amount or scope of the Change Order Work. Contractor shall have the right to be compensated for any undisputed Change Order Work amounts as determined to be undisputed in District's sole discretion.
- 5.4. Authorized Representative. No Change Order shall be valid or binding against District unless such Change Order has been executed by District's designated representative, who is the General Manager. District shall notify Contractor in writing if the designated representative is changed.
- 5.5. Limits. When applicable, the authority to execute a Change Order on this Project shall not exceed the amount allowed by law pursuant to Public Contract Code sections 20137-20142 et seq. Where Change Orders are in an amount between ten percent (10%) and twenty-five percent (25%) of the amount set forth in this Agreement and based on a need for additional quantities due to an increase in the unit quantities required to complete the project in excess of the District's Engineer's estimate of unit quantities as set forth in the Invitation to Bid, Contractor shall be paid pursuant to Public Contract Code sections 20143 and 20139 and section 4 of the Standard Specifications, State of California, Business, Transportation and Housing Agency, May 2006 Issued by the Department of Transportation ("Caltrans Standard Specifications") referred to in Exhibit "A" and incorporated herein by reference.

6. REPRESENTATIONS BY CONTRACTOR

- 6.1. Contractor understands and agrees that District has limited knowledge in the construction specified in the description of work. Contractor has represented itself to be expert in these fields and understands that District is relying upon such representation.
- 6.2. Contractor represents and warrants that it is a lawful entity possessing all required licenses and authorities to do business in the State of California and perform all aspects of this Agreement.
- 6.3. Contractor shall not commence any work under this Agreement or provide any other services, or materials, in connection therewith until Contractor has received written

- authorization from the General Manager, or his/her designee (“Notice to Proceed”) to do so.
- 6.4. Contractor represents and warrants that the people executing this Agreement on behalf of Contractor have the authority of Contractor to sign this Agreement and bind Contractor to the performance of all duties and obligations assumed by Contractor herein.
 - 6.5. Contractor represents and warrants that any employee, contractor, subcontractor and agent who will be performing any of the duties and obligations of Contractor herein possess all required licenses and authorities, as well as the experience and training, to perform such tasks.
 - 6.6. Contractor represents and warrants that the allegations contained in its Proposal are true and correct.
 - 6.7. Contractor understands that District considers the representations made herein to be material and would not enter into this Agreement with Contractor if such representations were not made.
 - 6.8. Retention and Access of Books and Records. Contractor represents and warrants that it shall maintain books, records, documents, reports and other materials developed under this Agreement as follows:
 - 6.8.1. Contractor shall hold and possess as the property of District all papers, books, files, correspondence and other records of all kinds which at any time shall come into its possession or under its control relating only to services performed by Contractor under this Agreement for a minimum period of five (5) years, or for any longer period required by law, from the date said papers came into the possession of Contractor pursuant to this Agreement.
 - 6.8.2. Any records or documents required to be maintained by Contractor pursuant to this Agreement shall be made available to District for inspection or audit, at any time during Contractor’s regular business hours provided District provides Contractor with seven (7) days advanced written or oral notice. Copies of such documents shall, at no cost to District, be provided to District for inspection at Contractor’s address indicated for receipt of notices under this Agreement.
 - 6.8.3. Contractor shall surrender all papers maintained by Contractor pursuant to Subparagraph 6.8.1 of this Agreement within thirty (30) days of termination of this Agreement.
 - 6.8.4. Contractor represents and warrants that it has not been engaged by, nor will it be engaged by and owes no duty of performance to any other person or entity that would constitute a conflict. For breach or violation of this warranty, District shall amongst other remedies at law, have the right to terminate this Agreement without liability, or at its sole discretion, to deduct from the Agreement price or consideration, or otherwise recover the full amount of such fee, commission, percentage brokerage fee, gift or contingent fee paid or received from another entity or person.
 - 6.9. Contractor shall perform pursuant to this Agreement in accordance with and in full compliance with all applicable Federal, State and local statutes, rules, regulations and

policies and procedures, regardless of whether they are expressly set forth in this Agreement. It is understood that in the event District is investigated or audited by any State or Federal governmental agency, or any other recognized investigative/auditing entity, Contractor shall fully cooperate with such agencies' reasonable and lawful request for information.

7. TERM OF AGREEMENT

This Agreement shall commence on the date first written above and shall remain in effect until the services provided as outlined in Section 3, ("SCOPE OF WORK TO BE PERFORMED BY Contractor"), have been completed, unless otherwise terminated as provided for in this Agreement.

8. COMPENSATION

The total compensation payable under this Agreement shall be in accordance with the item prices incorporated within the Proposal submitted by Contractor for labor, materials and all other services related to the performance of this Agreement, attached hereto as Exhibit "B" and incorporated herein as though fully set forth. The total compensation payable under this Agreement shall not exceed «Cost_of_Original_Contract».

9. PAYMENT AND RETENTION OF FUNDS

District shall pay Contractor for completed and approved services upon presentation and approval of its itemized billing, subject to the following.

9.1. Retention.

9.1.1. In accordance with Cal. Pub. Contract Code §§ 7201 and 9203, District shall generally retain five percent (5%) of the total compensation payable under this Agreement until the Work to be performed has been completed in accordance with this Agreement, as determined by District, and payment in full of all of Contractor's subcontractors has been certified.

9.1.2. The 5% retention amount may be exceeded if the District's Board has approved a finding, during a properly noticed and normally scheduled public hearing conducted either prior to or concurrent with authorizing this Project to go out to bid, that the Project is substantially complex and therefore requires a higher retention amount than 5%. Should the retention amount exceed 5% for this Project, then the actual retention amount will be listed in the Plans and Specifications, along with the findings justifying the increased retention amount.

9.2. Substitution of Retention.

9.2.1. Contractor may elect to substitute securities for any retention of funds by District to ensure performance under this Agreement. At the request and expense of Contractor, securities equivalent to the amount retained shall be deposited with the District, or with a state or federally chartered bank in this state as the escrow agent, who shall then return the securities to Contractor once the Work to be performed has been completed in accordance with this Agreement, as determined by District, and payment in full of all of Contractor's subcontractors has been certified.

9.2.2. Alternatively, Contractor may request and District shall make payment of retentions earned directly to the escrow agent at the expense of Contractor. Contractor, at its sole cost and expense, may direct the investment of the payments

into securities, and Contractor shall receive the interest earned on the investments upon the same terms provided for in this Section for securities deposited by Contractor. Once the Work to be performed has been completed in accordance with this Agreement, as determined by District, and payment in full of all of Contractor's subcontractors has been certified, Contractor shall receive from the escrow agent all securities, interest, and payments received by the escrow agent from District, pursuant to the terms of this Section.

- 9.2.3. Securities eligible for investment under this Section shall include those listed in Cal. Gov. Code § 16430, bank or savings and loan certificates of deposit, interest-bearing demand deposit accounts, standby letters of credit, or any other security mutually agreed to by District and Contractor. Contractor shall be the beneficial owner of any securities substituted for retained funds and shall receive any interest thereon.
- 9.2.4. Substitution of securities shall be conducted through an Escrow Agreement substantially similar to that found in Cal. Pub. Contract Code § 22300(f).
- 9.2.5. Notwithstanding any other provision in this Section, substitution of securities is prohibited where funding for the Project, in whole or in part, will be provided by the Farmers Home Administration of the United States Department of Agriculture pursuant to the Consolidated Farm and Rural Development Act (7 U.S.C. Sec. 1921 et seq.), or where otherwise disallowed by federal law.

10. METHOD OF PAYMENT

- 10.1. Contractor shall at any time prior to the fifteenth (15th) day of any month, submit to District's General Manager or his/her designee, a complete and accurate written claim for compensation for services performed. The claim shall be in a format approved by District. District shall make no payment prior to the claims being approved in writing by the General Manager or his/her designee.
- 10.2. After determining that the claim is a proper payment request, the General Manager, or his/her designee, shall submit to District's Auditor/Controller undisputed and properly submitted claims approved for payment within ten (10) days following the date the claim was submitted to his/her Department.
- 10.3. Contractor may expect to receive payment within a reasonable time thereafter and in any event in the normal course of business within thirty (30) days after the undisputed and properly submitted claim is submitted.
- 10.4. Any claim determined to be an improper payment request shall be returned to Contractor as soon as practicable, but not later than seven (7) days, after receipt with a written explanation as to why the claim is an improper request for payment.
- 10.5. In order for prompt payment to be made by District pursuant to Public Contract Code §20104.50, Contractor must properly fill out all written claims for compensation for services performed.
- 10.6. District shall pay interest at the legal rate set forth in Code of Civil Procedure §685.010 in the event payment is not made within thirty (30) days of an undisputed properly submitted request.

11. INDEMNIFICATION

- 11.1. Contractor agrees to the fullest extent permitted by law to indemnify, defend, protect and hold District and its representatives, officers, directors, designees, employees, agents, successors and assigns harmless from any and all claims, expenses, liabilities, causes of action, demands, losses, penalties, attorneys' fees and costs, in law or equity, of every kind and nature whatsoever arising out of or in connection with Contractor's negligent acts and omissions or willful misconduct under this Agreement ("Claims"), whether or not arising from the passive negligence of District, but does not include Claims that are finally determined to be the result of the sole negligence or willful misconduct of District.
- 11.2. Contractor agrees to defend with counsel acceptable to District, indemnify and hold District harmless from all Claims, including but not limited to:
 - 11.2.1. Personal injury, including but not limited to bodily injury, emotional injury, sickness or disease or death to persons including but not limited to District's representatives, officers, directors, designees, employees, agents, successors and assigns, subcontractors and other third parties and/or damage to property of anyone (including loss of use thereof) arising out of Contractor's negligent performance of, or willful misconduct surrounding, any of the terms contained in this Agreement, or anyone directly or indirectly employed by Contractor or anyone for whose acts Contractor may be liable;
 - 11.2.2. Liability arising from injuries to Contractor and/or any of Contractor's employees or agents arising out of Contractor's negligent performance of, or willful misconduct surrounding, any of the terms contained in this Agreement, or anyone directly or indirectly employed by Contractor or anyone for whose acts Contractor may be liable;
 - 11.2.3. Penalties imposed upon account of the violation of any law, order, citation, rule, regulation, standard, ordinance or statute caused by the negligent action or inaction, or willful misconduct of Contractor or anyone directly or indirectly employed by Contractor or anyone for whose acts Contractor may be liable, including but not limited to:
 - a) Any loss of funding, penalties, fees, or other costs resulting from Contractor's failure to adhere to Disadvantaged Business Enterprise requirements and/or goals, as determined by District or such other lawful entity in charge of monitoring Disadvantaged Business Enterprise compliance;
 - b) Any loss of funding, penalties, fees, or other costs resulting from Contractor's failure to adhere to prevailing wage requirements, as determined by District, the California Department of Industrial Relations, or such other lawful entity in charge of monitoring prevailing wage compliance;
 - 11.2.4. Infringement of any patent rights which may be brought against District arising out of Contractor's work;
 - 11.2.5. Any violation or infraction by Contractor of any law, order, citation, rule, regulation, standard, ordinance or statute in any way relating to the occupational health or safety of employees; and

11.2.6. Any breach by Contractor of the terms, requirements or covenants of this Agreement.

11.3. The indemnification provisions of this Agreement shall extend to Claims occurring after this Agreement is terminated, as well as while it is in force.

12. INDEPENDENT CONTRACTOR

12.1. In all situations and circumstances arising out of the terms and conditions of this Agreement, Contractor is an independent contractor, and as an independent contractor, the following shall apply:

12.2. Contractor is not an employee or agent of District and is only responsible for the requirements and results specified by this Agreement.

12.3. Contractor shall be responsible to District only for the requirements and results specified by this Agreement and except as specifically provided in this Agreement, shall not be subject to District's control with respect to the physical actions or activities of Contractor in fulfillment of the requirements of this Agreement.

12.4. Contractor is not, and shall not be, entitled to receive from, or through, District, and District shall not provide, or be obligated to provide, Contractor with Worker's Compensation coverage or any other type of employment or worker insurance or benefit coverage required or provided by any Federal, State or local law or regulation for, or normally afforded to, an employee of District.

12.5. Contractor shall not be entitled to have District withhold or pay, and District shall not withhold or pay, on behalf of Contractor, any tax or money relating to the Social Security Old Age Pension Program, Social Security Disability Program, or any other type of pension, annuity, or disability program required or provided by any Federal, State or local law or regulation.

12.6. Contractor shall not be entitled to participate in, or receive any benefit from, or make any claim against any District fringe benefit program, including, but not limited to, District's pension plan, medical and health care plan, dental plan, life insurance plan, or any other type of benefit program, plan, or coverage designated for, provided to, or offered to District's employee.

12.7. District shall not withhold or pay, on behalf of Contractor, any Federal, State, or local tax, including, but not limited to, any personal income tax, owed by Contractor.

12.8. Contractor is, and at all times during the term of this Agreement shall represent and conduct itself as, an independent contractor, not an employee of District.

12.9. Contractor shall not have the authority, express or implied, to act on behalf of, bind or obligate District in any way without the written consent of District.

13. INSURANCE

13.1. Contractor hereby agrees at its own cost and expense to procure and maintain, during the entire term of this Agreement and any extended term therefore, insurance in a sum acceptable to District and adequate to cover potential liabilities arising in connection with the performance of this Agreement and in any event not less than the minimum limit set forth in the "Minimum Insurance Amounts" attachment to the Plans and Specifications which are incorporated as if set forth fully herein.

13.2. Special Insurance Requirements. All insurance required shall:

- 13.2.1. Be procured from California admitted insurers (licensed to do business in California) with a current rating by Best's Key Rating Guide, acceptable to District. A rating of at least A-VII shall be acceptable to District; lesser ratings must be approved in writing by District.
- 13.2.2. Be primary coverage as respects District and any insurance or self-insurance maintained by District shall be in excess of Contractor's insurance coverage and shall not contribute to it.
- 13.2.3. Name District as an additional insured on all policies, except Workers' Compensation, and provide that District may recover for any loss suffered by District by reason of Contractor's negligence.
- 13.2.4. State that it is primary insurance and regards District as an additional insured and contains a cross-liability or severability of interest clause.
- 13.2.5. Not be canceled, non-renewed or reduced in scope of coverage until after thirty (30) days written notice has been given to District. However, Contractor may not terminate such coverage until it provides District with proof that equal or better insurance has been secured and is in place. Cancellation or change without the prior written consent of District shall, at the option of District, be grounds for termination of this Agreement.
- 13.2.6. If this Agreement remains in effect more than one (1) year from the date of its original execution, District may, at its sole discretion, require an increase in the amount of liability insurance to the level then customary in similar District Agreements by giving sixty (60) days notice to Contractor.

13.3. Additional Insurance Requirements.

- 13.3.1. District is to be notified immediately of all insurance claims. District is also to be notified if any aggregate insurance limit is exceeded.
- 13.3.2. The comprehensive or commercial general liability shall contain a provision of endorsements stating that such insurance:
 - a) Includes contractual liability;
 - b) Does not contain any exclusions as to loss or damage to property caused by explosion or resulting from collapse of buildings or structures or damage to property underground, commonly referred to by insurers as the "XCU Hazards";
 - c) Does not contain a "pro rata" provision which looks to limit the insurer's liability to the total proportion that its policy limits bear to the total coverage available to the insured;
 - d) Does not contain an "excess only" clause which requires the exhaustion of other insurance prior to providing coverage;
 - e) Does not contain an "escape clause" which extinguishes the insurer's liability if the loss is covered by other insurance;
 - f) Includes District as an additional insured; and

g) States that it is primary insurance and regards District as an additional insured and contains a cross-liability or severability of interest clause.

13.4. Deposit of Insurance Policy. Promptly on issuance, reissuance, or renewal of any insurance policy required by this Agreement, Contractor shall, if requested by District, cause to be given to District satisfactory evidence that insurance policy premiums have been paid together with a duplicate copy of the policy or a certificate evidencing the policy and executed by the insurance company issuing the policy or its authorized agent.

13.5. Certificates of Insurance. Complete copies of certificates of insurance for all required coverages including additional insured endorsements shall be attached hereto as Exhibit "C" and incorporated herein as though fully set forth.

13.6. Additional Insurance. Nothing in this, or any other provision of this Agreement, shall be construed to preclude Contractor from obtaining and maintaining any additional insurance policies in addition to those required pursuant to this Agreement.

14. WORKERS' COMPENSATION CERTIFICATION

14.1. Prior to the commencement of work, Contractor shall sign and file with District the following certification: "I am aware of the provisions of California Labor Code §§3700 et seq. which require every employer to be insured against liability for workers' compensation or to undertake self-insurance in accordance with the provisions of that code, and I will comply with such provisions before commencing the performance of the work of this contract."

14.2. This certification is included in this Agreement and signature of the Agreement shall constitute signing and filing of the certificate.

14.3. Contractor understands and agrees that any and all employees, regardless of hire date, shall be covered by Workers' Compensation pursuant to statutory requirements prior to beginning work on the Project.

14.4. If Contractor has no employees, initial here: _____.

15. WARRANTY

15.1. One Year Warranty. Contractor agrees to provide a one-year warranty for all of its work and component parts and guarantees that all work shall be performed in a professional and workman-like manner and be free from defects. Contractor guarantees to timely correct all work performed by it under this Agreement which District determines to be defective in design, material and/or workmanship within a period of one (1) year from the date of the completion of the Work. The warranties set forth in this Agreement shall be in addition to, and not in lieu of, all other statutory and case law warranties and obligations of Contractor. Contractor expressly agrees that all warranties made by Contractor, all obligations under this Agreement and all remedies for breach of such warranties shall survive this Agreement in the event it is terminated or expires for any reason prior to the running of the full warranty periods listed above.

15.2. Materials. All materials furnished by Contractor shall be new, manufactured during the current year, of first quality and carrying full manufacturer's warranty. Contractor shall be responsible for any expiration of manufacturer or other warranties of material or equipment being supplied for this Agreement. Contractor guarantees that all

warranties of material and equipment shall become effective when the project is accepted by District's Board of Supervisors, not at time of installation by Contractor.

- 15.3. Manufacturers' Warranty Information. Contractor agrees to promptly provide such information and maintenance recommendations to District at the inception of Contractor's work to the extent such information is reasonably available.

16. DEFAULT AND REMEDIES

- 16.1. Default. In the event that (i) Contractor files a petition requesting relief under any bankruptcy act, or is adjudged as bankrupt, or makes a general assignment for the benefit of creditors or has a receiver appointed on account of its insolvency, or (ii) Contractor refuses or is unable, for whatever reason, to supply enough properly skilled workers or proper materials to complete the Project, or (iii) Contractor fails to follow the directions of District, or (iv) Contractor fails to make prompt payment to its subcontractors and suppliers for materials or labor supplied or permits any lien to be imposed upon all or any portion of the Project, or (v) Contractor disregards any laws or orders of any public or private authority having jurisdiction over the Work or the Project, or (vi) Contractor fails to perform in accordance with any of the terms of this Agreement or breaches any provision of this Agreement, District may give notice of such failure or breach to Contractor, identifying the failure or breach of this Agreement. Should any such failure or breach continue for twenty-four (24) hours after delivery of notice without a good faith effort on the part of Contractor to commence all necessary corrective action, or should such a breach continue despite Contractor's efforts for forty-eight (48) hours, then at that time such failure shall be deemed a default by Contractor under this Agreement and District shall have all rights and remedies available at law or in equity, including the right to terminate this Agreement. Without limiting its rights and remedies, District may then proceed as follows:

- 16.1.1. Without terminating this Agreement or the obligations of Contractor hereunder as to all of the Work required to be performed or furnished by Contractor pursuant to this Agreement, District may require Contractor, at Contractor's expense, to cure such default(s) as may exist in the performance of Contractor's obligations hereunder within forty-eight (48) hours after such default(s) has/have occurred including but not limited to repairing, replacing and correcting material or Work determined by District to be defective or not complying with the requirements of this Agreement. Should Contractor fail to timely repair, replace and/or correct non-complying or defective materials and workmanship or otherwise cure its default(s) hereunder, and in the case of emergencies in which case District may act immediately if Contractor is not available or is not responding, and without further notice, District may make required repairs, replacements and other corrections or otherwise remedy the default by Contractor pursuant to the subparagraph below.

- 16.1.2. Without terminating this Agreement or the obligations of Contractor hereunder as to all of the Work required to be performed or furnished by Contractor pursuant to this Agreement, District may engage another contractor to perform such portion of Contractor's Work required pursuant to this Agreement or furnish any materials or other items required hereunder as District in its sole discretion may deem necessary to avoid delay in the progress of the Work, and in connection therewith, District may perform such Work or any portion thereof itself or have the same performed by others and District may procure all necessary materials, equipment or other items

required for the continued progress of such Work. The costs incurred by District as a result of engaging another contractor shall be deducted from the compensation payable pursuant to this Agreement and if District's costs exceed or may reasonably be anticipated to exceed the balance of the compensation due to Contractor for such work, such excess, or anticipated excess, shall be immediately due and owing from Contractor to District and may be withheld from any funds due to Contractor pursuant to this Agreement or any other agreement.

- 16.1.3. District may terminate Contractor's right to perform upon written notice and District shall then have the option of completing the Work or any portion thereof by exercise of its interest under the performance bond issued in favor by Contractor, or having such Work in whole or in part be completed by others for Contractor's account. A calculation shall take place at the conclusion of the Project wherein to the degree the sum of District's costs and any amounts paid to complete the Project exceed the compensation payable pursuant to this Agreement, then any such excess shall be immediately due and owing from Contractor to District.
- 16.2. Damages. Contractor shall be liable for all damages suffered by District by reason of Contractor's default in any provision of this Agreement and the exercise of District of its option to terminate this Agreement shall not release Contractor of such liability. Contractor shall have no right to receive any further payment after a default has occurred until such time as the Work to be performed by Contractor pursuant hereto has been completed and accepted by District and damages suffered by District, if any, ascertained. Damages shall include by way of illustration, but not of exclusion, District's costs of completing the Work which exceeds the compensation payable pursuant to this Agreement, other general, liquidated, special or consequential damages, attorney fees and costs.
- 16.3. Actions After Default. Should District exercise any of its options, remedies or rights granted pursuant to the terms of this Agreement in the event of a default by Contractor, District at its sole election may, but shall not be obligated to, use any materials, supplies, tools or equipment on the work site which belong to Contractor to complete the Work required to be completed by Contractor, whether such work is completed by District or by others, and Contractor agrees that it shall not remove such materials, supplies, tools and equipment from the work site unless directed in writing by District to do so.
- 16.4. Limit on Force Majeure Damages. Contractor shall not be responsible for repairing or restoring damage to work caused by an act of God in excess of five (5) percent of the contract amount, provided that the work damaged is built in accordance with accepted and applicable building standards and the plans and specifications of District. In the event of such damage, District may, at its option, elect to terminate this Agreement. For purposes of this Agreement, an "act of God" shall be defined as an earthquake in excess of 3.5 on the Richter Scale and a tidal wave.
- 16.5. Resolution of Claims. District and Contractor agree to follow and comply with the mediation, arbitration, claim, civil action procedure and trial de novo provisions set forth in California Public Contracts Code §§ 9204 and 20104 – 20104.6.
- 16.6. No Limitation of Rights. The options and rights granted to District herein shall not be deemed as limitations upon the other rights and remedies of District in the event of a

failure of performance or breach by Contractor, and District shall be entitled to exercise the rights and remedies hereinabove specified and all other rights and remedies which may be provided in this Agreement or by law or in equity, either cumulatively or consecutively, and in such order as District in its sole discretion shall determine.

17. NON-DISCRIMINATION

- 17.1. During the performance of this Agreement, Contractor and its subcontractors shall not unlawfully discriminate, harass or allow harassment against any employee or applicant for employment because of sex, race, color, ancestry, religious creed, national origin, physical disability (including HIV and AIDS), mental disability, medical condition (cancer), age (over forty (40)), marital status and denial of family care leave.
- 17.2. Contractor and its subcontractors shall insure that the evaluation and treatment of their employees and applicants for employment are free from such discrimination and harassment.
- 17.3. Contractor and its subcontractors shall comply with the provisions of the Fair Employment and Housing Act (Gov. Code §12990 (a-f) et seq.) and the applicable regulations promulgated thereunder (California Code of Regulations, Title 2, Section 7285 et seq.).
- 17.4. The applicable regulations of the Fair Employment and Housing Commission implementing Government Code §12990 (a-f), set forth in Chapter 5 of Division 4 of Title 2 of the California Code of Regulations, are incorporated into this Agreement by reference and made a part hereof as if set forth in full.
- 17.5. The applicable regulations of Section 504 of the Rehabilitation Act of 1973 (29 U.S.C. §794 (a)) are incorporated into this Agreement by reference and made a part hereof as if set forth in full.
- 17.6. Contractor and its subcontractors shall give written notice of their obligations under this clause to labor organizations with which they have a collective bargaining or other agreement.
- 17.7. Contractor shall include the nondiscrimination and compliance provisions of this clause in all subcontracts to perform Work under this Agreement.

18. DISADVANTAGED BUSINESS ENTITY COMPLIANCE

- 18.1. When applicable, Contractor and its subcontractors shall reference and abide by the guidance and Disadvantaged Business Enterprise (“DBE”) specifications contained in the California Department of Transportation’s Standard Specifications.
- 18.2. Contractor represents and warrants that it has fully read the applicable DBE requirements pertaining to this Project and has fully and accurately completed any and all required DBE forms.
- 18.3. Contractor represents and warrants that it will comply with all applicable DBE requirements for this Project.
- 18.4. Contractor shall comply with the applicable DBE provisions attached hereto as Exhibit “D” and incorporated by this reference as though fully set forth herein.
- 18.5. If any state or federal funds are withheld from District or not reimbursed to District due to Contractor’s failure to either comply with the DBE requirements set forth in the RFP

and this Agreement, or to meet the mandatory DBE goals as determined by District, Caltrans, the Federal Highway Administration, and/or any other state or federal agency contributing funds to the Project, then Contractor shall fully reimburse District the amount of funding lost. District reserves the right to deduct any such loss in funding from the amount of compensation due to Contractor under this Agreement.

18.6. In addition to the above, Contractor's failure to comply with DBE requirements/goals shall subject it to such sanctions as are permitted by law, which may include, but shall not be limited to the following:

18.6.1. Termination of this Agreement;

18.6.2. Withholding monthly progress payments;

18.6.3. Denial of payment for any portion of the Project that was committed at the time of the execution of this Agreement to be performed by a DBE subcontractor, but was completed by Contractor or a substitute non-DBE subcontractor;

18.6.4. Compensatory, special, incidental, liquidated and other damages; and/or

18.6.5. Designation of Contractor as "nonresponsible," and disqualification from bidding on future public works projects advertised by District.

19. PREVAILING WAGE

19.1. Contractor and its subcontractors shall pay all workers employed on the Project the higher of either the rates determined by the Director of the California Department of Industrial Relations ("DIR") or, when applicable, the Davis-Bacon Federal wage rates as supplemented by the Department of Labor regulations. The Davis-Bacon Federal wage rates are attached to the RFP. Copies of the State prevailing rate of per diem wages are on file with the Department of Industrial Relations, Division of Apprenticeship Standards, 445 Golden Gate Avenue, San Francisco, California, and at District's Department of Public Works, and are available to Contractor and any other interested party upon request. Contractor shall post the prevailing rate of per diem wages to be posted at the Project site.

19.2. Contractor is responsible for compliance with the provisions herein.

19.3. Mandatory Registration with the Department of Industrial Relations – NEW REQUIREMENTS PURSUANT TO SB 854.

19.3.1. Contractor and its subcontractors shall register with the DIR and pay all applicable fees as set forth in Labor Code section 1725.5.

19.3.2. Contractor and its subcontractors acknowledge that they shall not be listed on any bid proposal for a public works project (submitted on or after March 1, 2015) unless registered with the DIR pursuant to Labor Code section 1725.5. The requirements of this section shall apply unless one of the limited exceptions provided under Labor Code Section 1771.1(a) applies.

19.3.3. Contractor and its subcontractors acknowledge that they shall not be awarded any contract for public work on a public works project (awarded on or after April 1, 2015) unless registered with the DIR pursuant to Labor Code section 1725.5.

19.3.4. The Project described herein is subject to compliance monitoring and enforcement with the DIR.

19.3.5. For further information concerning compliance with SB 854, please visit: <http://www.dir.ca.gov/Public-Works/SB854.html> .

19.4. Cognizance of Violations by District.

19.4.1. Contractor understands and agrees that District shall take cognizance of violations of Chapter 1 of Part 7 of Division 2 of the California Labor Code committed in the course of the execution of this Agreement, and shall promptly report any suspected violations to the Labor Commissioner.

19.4.2. If Contractor determines as a result of its own investigation that there has been a violation of Chapter 1 of Part 7 of Division 2 of the California Labor Code and withholds payment to Contractor, the procedures in California Labor Code §1771.6 shall be followed.

19.4.3. Contractor may bring an action in a court of competent jurisdiction to recover from District the difference between the wages actually paid to an employee and the wages that were required to be paid to an employee pursuant to Chapter 1 of Part 7 of Division 2 of the California Labor Code, any penalties required to be paid pursuant to Chapter 1 of Part 7 of Division 2 of the California Labor Code, and costs and attorney's fees related to the action, if either of the following is true:

- a) District previously affirmatively represented to Contractor in writing, in the call for bids, or otherwise, that the Work was not a "public work," as defined in Chapter 1 of Part 7 of Division 2 of the California Labor Code; or
- b) District received actual written notice from the Department of Industrial Relations that the Work is a "public work," as defined in Chapter 1 of Part 7 of Division 2 of the California Labor Code, and failed to disclose that information to Contractor before the bid opening or award.

19.5. Labor Compliance Rates and Payroll Records.

19.5.1. Contractor agrees to comply with §§1775 and 1776 of the California Labor Code relating to the payment of prevailing wage and the maintenance of certified payroll records and to make the certified payroll records available for inspection at all reasonable hours at Contractor's principal office. The responsibility for compliance with these provisions is fixed with Contractor. Contractor understands and agrees that it shall, as a penalty to District, forfeit specific monetary fines for each worker paid less than the prevailing wage rates as determined by the Labor Commissioner for the work or craft in which the worker is employed for any Work done pursuant to this Agreement.

19.5.2. Prevailing Wage Compliance For those Projects subject to DIR Monitoring and Enforcement. Contractor has reviewed and agrees to comply with any applicable provisions for those Projects subject to Department of Industrial Relations (DIR) Monitoring and Enforcement of prevailing wages. District hereby notifies Contractor that Contractor is responsible for complying with the requirements of Senate Bill 854 (SB854) regarding certified payroll record reporting. Further information concerning the requirements of SB854 is available on the DIR website located at: <http://www.dir.ca.gov/Public-Works/PublicWorksEnforcement.html>.

19.5.3. Contractor shall be liable for penalties pursuant to this section when a subcontractor on the Project fails to pay its workers the general prevailing rate of per diem wages and any of the following conditions are met:

- a) Contractor had knowledge of that failure of the subcontractor to pay the specified prevailing rate of wages to those workers; or
- b) Contractor fails to comply with the following requirement: The contract executed between Contractor and the subcontractor for the performance of Work on the Project shall include a copy of the provisions of California Labor Code §§1771, 1775, 1776, 1777.5, 1813 and 1815; and
- c) Contractor fails to comply with the following requirement: Contractor shall monitor the payment of the specified general prevailing rate of per diem wages by the subcontractor to the employees, by periodic review of the certified payroll records of the subcontractor; and
- d) Upon becoming aware of the failure of the subcontractor to pay his or her workers the specified prevailing rate of wages, Contractor shall diligently take corrective action to halt or rectify the failure, including, but not limited to, retaining sufficient funds due the subcontractor for work performed on the public works project; and
- e) Prior to making final payment to the subcontractor for Work performed on the Project, Contractor shall obtain an affidavit signed under penalty of perjury from the subcontractor that the subcontractor has paid the specified general prevailing rate of per diem wages to his or her employees on the Project and any amounts due pursuant to California Labor Code §1813.

19.6. Work Day and Work Week Requirements. Contractor agrees to comply with §§1810 through 1815 of the California Labor Code and, when applicable, sections 103 and 107 of the Contract Work Hours and Safety Standards Act, 40 U.S.C. §§3700 et seq., as supplemented by the Department of Labor regulations, which provide that Contractor's workers and its subcontractor's workers may not be required or permitted to work more than eight (8) hours in any one (1) calendar day and forty (40) hours in any one (1) calendar week. Further, work performed by employees of Contractor or its subcontractor in excess of eight (8) hours per day, and forty (40) hours during any one (1) week, shall be compensated for all hours worked in excess of eight (8) hours per day at not less than one and one-half (1½) times the basic rate of pay. The responsibility for compliance with these provisions is fixed with Contractor. Contractor understands and agrees that it shall, as a penalty to District, forfeit specific monetary fines to District should Contractor or its subcontractors fail to comply with the provisions contained within this Paragraph.

19.7. Apprenticeship Requirements.

19.7.1. Contractor agrees to comply with §§1777.5, 1777.6 and 1777.7 of the California Labor Code relating to the employment of apprentices and to provide District with copies of any contract award information and verified statements of the journeyman and apprentice hours performed pursuant to this Agreement as required by §1777.5(e). The responsibility for compliance with these provisions is fixed with Contractor for all apprenticeable occupations, where journeymen in the craft are

employed on the public work, in a ratio of not less than one (1) apprentice for each five (5) journeymen (unless an exemption is granted in accordance with §1777.5) and Contractor and its subcontractors shall not discriminate among otherwise qualified employees as indentured apprentices on any public work solely on the ground of race, religious creed, color, national origin, ancestry, sex, or age, except as provided in California Labor Code §3077. Only apprentices, as defined in California Labor Code §3077, who are in training under apprenticeship standards and who have signed written apprentice agreements will be employed on public works in apprenticeable occupations. This section shall not be enforced if the not-to-exceed amount of this Agreement set forth and/or incorporated in the “COMPENSATION” Section is less than thirty thousand dollars (\$30,000).

19.7.2. If the Project falls within the jurisdiction of California Labor Code §1777.5, District shall, within five (5) days of the award, send a copy of the award to the Division of Apprenticeship Standards. In addition, District shall notify the Division of Apprenticeship Standards of a finding of any discrepancy regarding the ratio of apprentices to journeymen within five (5) days of the finding.

19.8. Labor Standards Compliance Requirements.

19.8.1. It is Contractor’s responsibility to provide all labor compliance documentation from its subcontractors completely and accurately in a timely manner. Contractor is responsible to review promptly and then forward on all required documentation to District per the time schedules in the 1775 Handout. Included with the Labor Compliance Handout, District will provide training, documentation requirements, forms, etc., at the preconstruction conference or at a time designated by District.

19.8.2. In the event, during the review process of labor compliance documentation from District’s labor compliance monitor, inaccurate, missing or incomplete information was provided, the labor compliance monitor will request from Contractor the items, revisions and documentation needed. The cost of this additional labor compliance enforcement shall be borne by Contractor.

20. INELIGIBILITY

20.1. Contractor represents and warrants that it and its subcontractors are not ineligible to work for District due to violations of Labor Code §§1777.1 and 1777.7.

20.2. If Contractor is deemed ineligible to perform work on public works projects pursuant to Labor Code Sections 1777.1 or 1777.7, then Contractor shall be prohibited from bidding on, being awarded an agreement for, or performing work as a subcontractor on this Project, or any other public works project within the state of California.

21. SIGNAGE REQUIREMENTS

21.1. Project Identity Signage. Contractor is required to provide and install the required project identity signage as detailed in the Plans and Specifications, in the size and at the location indicated by the General Manager or his/her designee, and to maintain the signage in good condition for the duration of the Project. The signage may not be removed until the Notice of Completion is recorded or by written direction of the General Manager or his/her designee.

- 21.2. Required Employee Signage and Posters. Contractor is required to provide and install the Federal and State required employee posters and the required material pertaining to the required labor standards provisions are posted (including, but not limited to, WH-1321, OSHA 3165 and OFCCP-English, EFCCP-Spanish) at the worksite in a prominent and accessible place.
- 21.3. Section 3 Compliant Signage. If required by District, Contractor is directed to provide and install the “Offer for Employment” signage as detailed in the Plans and Specifications in the size and at the location indicated by the General Manager or his/her designee and to maintain the signage in good condition for the duration of the Project. The signage may not be removed until the Notice of Completion is recorded or by written direction of the General Manager or his/her designee.

22. CONFLICT OF INTEREST AND GRATUITIES

- 22.1. Contractor agrees that it presently has no interest and shall not acquire any interest, direct or indirect, which could conflict in any manner or degree with the performance of services required to be performed under this Agreement. Contractor further agrees that in the performance of this Agreement, no person having any such interest shall be employed.
- 22.2. Contractor agrees to designate such person or persons who have responsibility for carrying out the services under this Agreement and that such person or persons as may be designated shall take any and all actions necessary to comply with District’s Conflict of Interest Code adopted pursuant to California Government Code §81000 to the extent required thereunder.
- 22.3. If it is found, after notice and hearing by District, that gratuities (in the form of entertainment., gifts, or otherwise) were offered or given by Contractor, or any agent or representative of Contractor, to any officer, employee or agent of District with a view toward securing a contract or securing favorable treatment with respect to the awarding or amending or the making of any determinations with respect to the performance of this Agreement, District may, by written notice to Contractor, terminate the right of Contractor to proceed under this Agreement and/or may pursue such other rights and remedies provided by law or under this Agreement.
- 22.4. In the event this Agreement is terminated as provided herein, District shall be entitled to:
 - 22.4.1. Pursue the same remedies against Contractor as it could pursue in the event of a breach of the Agreement by Contractor; and
 - 22.4.2. As a penalty in addition to any other damages to which it may be entitled by law, to exemplary damages in an amount (as determined by District) which shall be not less than three (3) nor more than ten (10) times the costs incurred by Contractor in providing any such gratuities to any such officer, employee or agent.

23. HOUSING AND URBAN DEVELOPMENT ACT COMPLIANCE

When applicable, Contractor agrees to comply with Section 3 of the Housing and Urban Development Act of 1968 (42 U.S.C. 3601 et seq.) which provides that to the greatest extent feasible, Contractor shall provide job training, employment and contracting opportunities for

low- or very-low income residents in connection with the Project. The responsibility for compliance with these provisions is fixed with Contractor.

24. COPELAND “ANTI-KICKBACK” ACT COMPLIANCE

When applicable, Contractor agrees to comply with the Copeland Act (18 USC §874 and 40 USC §276c ; 29 C.F.R. Part 3) which precludes Contractor and its subcontractors from in any way inducing an employee to give up any part of the compensation to which he or she is entitled under his or her contract of employment. Contractor and its subcontractors shall submit a weekly statement of the wages paid to each employee performing on covered work during the preceding payroll period. Contractor understands and agrees that should Contractor its subcontractors induce an employee working on a covered contract to give up any part of the compensation to which he or she is entitled, the inducing party may be subject to a five thousand dollar (\$5,000) fine, or imprisonment for up to five (5) years, or both. Contractor also understands and agrees that willful falsification of the statement of compliance may subject the employer to civil or criminal prosecution and may be cause for contract termination or debarment. The responsibility for compliance with these provisions is fixed with Contractor.

25. FAIR LABOR STANDARDS ACT COMPLIANCE

When applicable, Contractor agrees to comply with the Fair Labor Standards Act of 1938 as amended (29 U.S.C. 201 et seq.) which establishes minimum wage, overtime pay, recordkeeping, and youth employment standards affecting full-time and part-time workers on the Project. The responsibility for compliance with these provisions is fixed with Contractor.

26. CERTIFICATION REGARDING DEBARMENT, SUSPENSION AND OTHER RESPONSIBILITY MATTERS

When applicable, Contractor agrees to execute a certification regarding debarment, suspension and other responsibility matters. The responsibility for compliance with this provision is fixed with Contractor.

27. FEDERAL EQUAL EMPLOYMENT OPPORTUNITY CONSTRUCTION CONTRACT SPECIFICATIONS

When applicable, Contractor agrees to incorporate the notice set forth in paragraph (d) of 41 C.F.R. 60-4.2 relating to the “Equal Opportunity Clause” and the “Standard Federal Equal Employment Specifications.” The responsibility for compliance with this provision is fixed with Contractor.

28. CLEAN AIR ACT AND THE FEDERAL WATER POLLUTION CONTROL ACT

When applicable, Contractor agrees to comply with all applicable standards, orders or regulations issued pursuant to the Clean Air Act (42 U.S.C. 7401 et seq.), the Federal Water Pollution Control Act as amended (33 U.S.C. 1251 et seq.), Presidential Executive Order 11738 and Environmental Protection Agency regulations set forth at 40 C.F.R. Part 15. Contractor understands and agrees that violations shall be reported to the Federal awarding agency and the Regional Office of the Environmental Protection Agency. The responsibility for compliance with these provisions is fixed with Contractor.

29. PROHIBITION ON THE USE OF FEDERAL FUNDS FOR LOBBYING

When applicable, Contractor shall file the required certification. Each tier certifies to the tier above that it will not and has not used Federal appropriated funds to pay any person or

organization for influencing or attempting to influence an officer or employee of any agency, a member of Congress, officer or employee of Congress, or an employee of a member of Congress in connection with obtaining any Federal contract, grant or any other award covered by 31 U.S.C. 1352. Each tier shall also disclose any lobbying with non-Federal funds that takes place in connection with obtaining any Federal award. Such disclosures are forwarded from tier to tier up to the recipient. The responsibility for compliance with this provision is fixed with Contractor.

30. FEDERAL EMPLOYMENT ELIGIBILITY VERIFICATION

Contractor shall verify name, date of birth and social security number, along with immigration information for non-citizens in order to verify the identity and employment eligibility of both citizen and non-citizen new hires. The responsibility for compliance with this provision is fixed with Contractor.

31. THE CIVIL RIGHTS, HCD AND AGE DISCRIMINATION ACT ASSURANCES

31.1. During the performance of this Agreement, Contractor assures that no otherwise qualified person shall be excluded from participation or employment, denied program benefits or be subjected to discrimination based on race, color, national origin, gender, age or handicap, under any program or activity funded by this Agreement, as required by Title VI of the Civil Rights Act of 1964, Title I of the Housing and Community Development Act of 1974, as amended, and the Age Discrimination Act of 1975, and all implementing regulations. The responsibility for compliance with these provisions is fixed with Contractor.

31.2. Contractor and its subcontractors shall not discriminate on the basis of race, color, national origin, or sex in the performance of this Agreement. Contractor shall carry out the applicable requirements of 49 C.F.R. Chapter 26 in the award and administration of Department of Transportation assisted contracts. Failure by Contractor to carry out these requirements is a material breach of this Agreement, which may result in the termination of this Agreement, or such other remedy as District deems appropriate. Contractor shall include the nondiscrimination and compliance provisions of this Paragraph in all subcontracts to perform Work under this Agreement.

32. FEDERAL EQUAL EMPLOYMENT OPPORTUNITY REQUIREMENTS

32.1. Contractor hereby agrees that it will incorporate or cause to be incorporated into any contract for construction work, or modification thereof, as defined in the regulations of the Secretary of Labor at 41 C.F.R. Chapter 60, which is paid for in whole or in part with funds obtained from the Federal Government or borrowed on the credit of the Federal Government pursuant to a grant, contract, loan insurance, or guarantee, or undertaken pursuant to any Federal program involving such grant, contract, loan, insurance, or guarantee, the following equal opportunity clause. For the purposes of this Subsection, the term "contractor" shall refer to Contractor, and the term "contract" shall refer to this Agreement: "During the performance of this contract, the Contractor agrees as follows:

- (1) The contractor will not discriminate against any employee or applicant for employment because of race, color, religion, sex, or national origin. The contractor will take affirmative action to ensure that applicants are employed, and that employees are treated during employment, without regard to their race, color,

religion, sex, or national origin. Such action shall include, but not be limited to the following: Employment, upgrading, demotion, or transfer, recruitment or recruitment advertising; layoff or termination; rates of pay or other forms of compensation; and selection for training, including apprenticeship. The contractor agrees to post in conspicuous places, available to employees and applicants for employment, notices to be provided by the contracting officer setting forth the provisions of this nondiscrimination clause.

- (2) The contractor will, in all solicitations or advertisements for employees placed by or on behalf of the contractor, state that all qualified applicants will receive consideration for employment without regard to race, color, religion, sex, or national origin.
- (3) The contractor will send to each labor union or representative of workers with which he has a collective bargaining agreement or other contract or understanding, a notice to be provided by the agency contracting officer, advising the labor union or workers' representative of the contractor's commitments under section 202 of Executive Order 11246 of September 24, 1965, and shall post copies of the notice in conspicuous places available to employees and applicants for employment.
- (4) The contractor will comply with all provisions of Executive Order 11246 of September 24, 1965, and of the rules, regulations, and relevant orders of the Secretary of Labor.
- (5) The contractor will furnish all information and reports required by Executive Order 11246 of September 24, 1965, and by the rules, regulations, and orders of the Secretary of Labor, or pursuant thereto, and will permit access to his books, records, and accounts by the contracting agency and the Secretary of Labor for purposes of investigation to ascertain compliance with such rules, regulations, and orders.
- (6) In the event of the contractor's non-compliance with the nondiscrimination clauses of this contract or with any of such rules, regulations, or orders, this contract may be canceled, terminated or suspended in whole or in part and the contractor may be declared ineligible for further Government contracts in accordance with procedures authorized in Executive Order 11246 of September 24, 1965, and such other sanctions may be imposed and remedies invoked as provided in Executive Order 11246 of September 24, 1965, or by rule, regulation, or order of the Secretary of Labor, or as otherwise provided by law.
- (7) the contractor will include the provisions of paragraphs (1) through (7) in every subcontract or purchase order unless exempted by rules, regulations, or orders of the Secretary of Labor issued pursuant to section 204 of Executive Order 11246 of September 24, 1965, so that such provisions will be binding upon each subcontractor or vendor. The contractor will take such action with respect to any subcontract or purchase order as may be directed by the Secretary of Labor as a means of enforcing such provisions including sanctions for noncompliance: Provided, however, that in the event the contractor becomes involved in, or is threatened with, litigation with a subcontractor or vendor as a result of such direction, the contractor may request the United States to enter into such litigation to protect the interests of the United States. ”

- 32.2. Contractor further agrees that it will be bound by the above equal opportunity clause with respect to its own employment practices when it participates in federally- assisted construction work; provided that if Contractor so participating is a State or local government, the above equal opportunity clause is not applicable to any agency, instrumentality, or subdivision of such government which does not participate in work on or under the Agreement.
- 32.3. Contractor agrees that it will assist and cooperate actively with the administering agency and the Secretary of Labor in obtaining the compliance of Contractors and subcontractors with the equal opportunity clause and the rules, regulations, and relevant orders of the Secretary of Labor, that it will furnish the Department and HUD and the Secretary of Labor such information as they may require for the supervision of such compliance, and that it will otherwise assist the administering agency in the discharge of the agency's primary responsibility for securing compliance.
- 32.4. Contractor further agrees that it will refrain from entering into any contract or contract modification subject to Executive Order 11246 of September 24, 1965, with a contractor debarred from, or who has not demonstrated eligibility for, government contracts and federally-assisted construction contracts, pursuant to the Executive Order and will carry out such sanctions and penalties for violation of the equal opportunity clause as may be imposed upon contractors and subcontractors by the administering agency or the Secretary of Labor pursuant to Part II, Subpart D of the Executive Order. In addition, Contractor agrees that if it fails or refuses to comply with these undertakings, District may take any or all of the following actions: Cancel, terminate, or suspend in whole or in part this funding commitment (contract, loan, grant, insurance, guarantee); refrain from extending any further assistance to the applicant under the program with respect to which the failure or refund occurred until satisfactory assurance of future compliance has been received from such Contractor; and refer the case to the Department of Justice for appropriate legal proceedings.

33. ASSIGNMENT OF CLAIMS – CLAYTON OR CARTWRIGHT ACTS

Contractor shall comply with the following provisions regarding the assignment of claims arising from either the Clayton Act or the Cartwright. For the purposes of this Section, the term "contractor" shall refer to Contractor, the term "awarding body" shall refer to District, and the term "public works contract" shall refer to this Agreement: "In entering into a public works contract or a subcontract to supply goods, services, or materials pursuant to a public works contract, the contractor or subcontractor offers and agrees to assign to the awarding body all rights, title, and interest in and to all causes of action it may have under Section 4 of the Clayton Act (15 U.S.C. Sec. 15) or under the Cartwright Act (Chapter 2 (commencing with Section 16700) of Part 2 of Division 7 of the Business and Professions Code), arising from purchases of goods, services, or materials pursuant to the public works contract or the subcontract. This assignment shall be made and become effective at the time the awarding body tenders final payment to the contractor, without further acknowledgment by the parties."

34. NON-COLLUSION

Contractor agrees he/she has executed and submitted with the Bid a Non-Collusion Affidavit that complies with Cal. Public Code §7106, included in Exhibit "B" and incorporated herein.

35. NOTICES AND REPORTS

35.1. All notices and reports under this Agreement shall be in writing and may be given by personal delivery or by mailing by certified mail, addressed as follows:

DISTRICT	CONTRACTOR
Salton Community Services District	«Contractor_Business_Name»
Attention: General Manager	«Contractor_Street_Address»
1209 Van Buren Ave.	«Contractor_City_State»
Salton City, CA 92274	

35.2. Notices and reports under this Agreement may be given by personal delivery or by mailing by certified mail at such other address as either Party may designate in a notice to the other Party given in such manner. Any notice given by mail shall be considered given when deposited in the United States Mail, postage prepaid, addressed as provided herein.

36. ENTIRE AGREEMENT

This Agreement contains the entire agreement between District and Contractor relating to the transactions contemplated hereby and supersedes all prior or contemporaneous agreements, understandings, provisions, negotiations, representations, or statements, either written or verbal.

37. ASSIGNMENT

Neither this Agreement nor any duties or obligations hereunder shall be assignable by Contractor without the prior written consent of District.

38. MODIFICATION

No modification, waiver, amendment, discharge, or change of this Agreement shall be valid unless the same is in writing and signed by the Party against whom the enforcement of such modification, waiver, amendment, discharge, or change is or may be sought.

39. CAPTIONS

Captions in this Agreement are inserted for convenience of reference only and do not define, describe or limit the scope or the intent of this Agreement or any of the terms thereof.

40. PARTIAL INVALIDITY

If any provision in this Agreement is held by a court of competent jurisdiction to be invalid, void, or unenforceable, the remaining provisions will nevertheless continue in full force without being impaired or invalidated in any way.

41. GENDER AND INTERPRETATION OF TERMS AND PROVISIONS

Words and expressions in the masculine gender include the feminine and neuter genders. Words and expressions in the singular include the plural and words and expressions in the plural include the singular. Contractor as used in this Agreement or in any other document referred to in or made a part of this Agreement shall likewise include both singular and the plural, a corporation, a partnership, individual, firm or person acting in any fiduciary capacity as executor, administrator, trustee or in any other representative capacity or any other entity. All covenants herein contained on the part of Contractor shall be joint and several if more than one person, firm or entity executes the Agreement.

42. WAIVER

No waiver of any breach or of any of the covenants or conditions of this Agreement shall be construed to be a waiver of any other breach or to be consent to any further or succeeding breach of the same or any other covenant or condition.

43. CHOICE OF LAW

The laws of the State of California shall govern this Agreement. This Agreement is made and entered into in Imperial County, California. Any action brought by either Party with respect to this Agreement shall be brought in a court of competent jurisdiction within said County.

44. AUTHORITY

44.1. Each individual executing this Agreement on behalf of Contractor represents and warrants that:

44.1.1. He/She is duly authorized to execute and deliver this Agreement on behalf of Contractor;

44.1.2. Such execution and delivery is in accordance with the terms of the Articles of Incorporation or Partnership, any by-laws or Resolutions of Contractor and;

44.1.3. This Agreement is binding upon Contractor in accordance with its terms.

44.2. Contractor shall deliver to District evidence acceptable to District of the foregoing within thirty days of execution of this Agreement.

45. COUNTERPARTS

This Agreement and any subsequent modifications may be executed in any number of counterparts, each of which when executed shall be an original, and all of which together shall constitute one and the same Agreement. No counterparts shall be effective until all Parties have executed a counterpart hereof.

46. TIMING

The Parties agree that time is of the essence in this Agreement.

47. REVIEW OF AGREEMENT TERMS

47.1. Each Party has had the opportunity to receive independent legal advice from its attorneys with respect to the advisability of making the representations, warranties, covenants and agreements provided for herein, and with respect to the advisability of executing this Agreement.

47.2. Each Party represents and warrants to and covenants with the other Party that:

47.2.1. This Agreement in its reduction to final written form is a result of extensive good faith negotiations between the Parties and/or their respective legal counsel; and

47.2.2. Parties and/or their legal counsel have carefully reviewed and examined this Agreement for execution by said Parties.

47.3. Any statute or rule of construction that ambiguities are to be resolved against the drafting party shall not be employed in the interpretation of this Agreement.

48. APPENDIX E OF THE TITLE VI ASSURANCES

During the performance of this contract, the Contractor, for itself, its assignees, and successors in interest agrees to comply with the following nondiscrimination statutes and authorities; including but not limited to:

48.1. Pertinent Nondiscrimination Authorities:

- a) Title VI of the Civil Rights Act of 1964 (42 U.S.C. § 2000d et seq, 78 stat. 252), (prohibits discrimination on the basis of race, color, national origin); and 49 CFR Part 21.
- b) The Uniform Relocation Assistance and Real Property Acquisition Policies Act of 1970, (42 U.S.C. § 4601), (prohibits unfair treatment of persons displaced or whose property has been acquired because of Federal or Federal-Aid programs and projects);
- c) Federal-Aid Highway Act of 1973, (23 U.S.C. § 324 et seq.), prohibits discrimination on the basis of sex);
- d) Section 504 of the Rehabilitation Act of 1973, (29 U.S.C. § 794 et seq.) as amended, (prohibits discrimination on the basis of disability); and 49 CFR Part 27;
- e) The Age Discrimination Act of 1975, as amended, (42 U.S.C. § 6101 et seq.), (prohibits discrimination on the basis of age);
- f) Airport and Airway Improvement Act of 1982, 949 U.S.C. § 4 71, Section 4 7123), as amended, (prohibits discrimination based on race, creed, color, national origin, or sex);
- g) The Civil Rights Restoration Act of 1987, (PL 100-209), (Broadened the scope, coverage and applicability of Title VI of the Civil Rights Act of 1964, The Age Discrimination Act of 1975 and Section 504 of the Rehabilitation Act of 1973, by expanding the definition of the terms “programs or activities” to include all the programs or activities of the Federal-aid recipients, subrecipients and contractors, whether such programs or activities are Federally funded or not);
- h) Titles II and III of the Americans with Disabilities Act, which prohibit discrimination on the basis of disability in the operation of public entities, public and private transportation systems, places of public accommodation, and certain testing entities (42 U.S.C. §§ 12131-12189) as implemented by Department of Transportation regulations at 49 C.F.R. parts 37 and 38;
- i) The Federal Aviation Administration’s Nondiscrimination statute (49 U.S.C. § 47123) (prohibits discrimination on the basis of race, color, national origin, and sex);
- j) Executive Order 12898, Federal Actions to Address Environmental Justice in Minority Populations and Low-Income Populations, which ensures discrimination against minority populations by discouraging programs, policies, and activities with disproportionately high and adverse human health or environmental effects on minority and low-income populations;

- k) Executive Order 13166, Improving Access to Services for persons with Limited English Proficiency, and resulting agency guidance, national origin discrimination includes discrimination because of limited English proficiency (LEP). To ensure compliance with Title VI, you must take reasonable steps to ensure that LEP persons have meaningful access to your programs (70 Fed. Reg. at 74087 to 74100);
- l) Title IX of the Education Amendment of 1972, as amended, which prohibits you from discriminating because of sex in education programs or activities (20 U.S.C. 1681 et seq).

IN WITNESS WHEREOF , the Parties have executed this Agreement on the day and year first above written.

SALTON COMMUNITY SERVICES DISTRICT «Contractor_Business_Name»

By: _____
Emmanuel Ramos
General Manager

By: _____
«Contractor_Name_for_Signature»

**EXHIBIT C – ARCHITECTURAL PLAN SET
NOT TO SCALE – SEE PLANWELL PLAN ROOM FOR FULL-SIZE SET**

**SALTON COMMUNITY SERVICES DISTRICT
SALTON CITY PARK
RESTROOM IMPROVEMENTS
2208-2210 IRIDESCENT DRIVE, THERMAL, CA 92274**

DISTRICT PROJECT NO. SCP-1

11B-306.1 General

Where space beneath an element is included as part of clear space under an element, the clear space shall not be prohibited beneath an element but shall not be considered as part of the clear floor or ground space or turning space.

11B-306.2 Toe clearance

Space under an element between the finish floor or ground and 9 inches (229 mm) above the finish floor or ground shall be considered toe clearance and shall comply with Section 11B-306.2.

11B-306.2.1 General

Space under an element between the finish floor or ground and 9 inches (229 mm) above the finish floor or ground shall be considered toe clearance and shall comply with Section 11B-306.2.

11B-306.2.2 Maximum depth

Toe clearance shall extend 25 inches (635 mm) maximum under an element.

11B-306.2.3 Minimum required depth

Where knee clearance is required under an element as part of a clear floor space, the knee clearance shall be 11 inches (279 mm) deep minimum at 9 inches (229 mm) above the finish floor or ground, and 8 inches (203 mm) deep minimum at 27 inches (686 mm) above the finish floor or ground.

11B-306.3 Knee clearance

Where knee clearance is required under an element as part of a clear floor space, the knee clearance shall be 11 inches (279 mm) deep minimum at 9 inches (229 mm) above the finish floor or ground, and 8 inches (203 mm) deep minimum at 27 inches (686 mm) above the finish floor or ground.

11B-306.3.1 General

Where knee clearance is required under an element as part of a clear floor space, the knee clearance shall be 11 inches (279 mm) deep minimum at 9 inches (229 mm) above the finish floor or ground, and 8 inches (203 mm) deep minimum at 27 inches (686 mm) above the finish floor or ground.

11B-306.3.2 Maximum depth

Toe clearance shall extend 25 inches (635 mm) maximum under an element.

11B-306.3.3 Minimum required depth

Where knee clearance is required under an element as part of a clear floor space, the knee clearance shall be 11 inches (279 mm) deep minimum at 9 inches (229 mm) above the finish floor or ground, and 8 inches (203 mm) deep minimum at 27 inches (686 mm) above the finish floor or ground.

11B-306.4 Door swing

Doors shall be permitted to swing into turning spaces.

11B-306.5 Width

Knee clearance shall be 30 inches (762 mm) wide minimum.

11B-306.5.1 Forward approach

Where a clear floor or ground space is located in an alcove or maneuvering clearance shall be provided in accordance with Section 11B-305.7.1 and 11B-305.7.2.

11B-306.5.2 Parallel approach

Alcoves shall be 60 inches (1524 mm) wide minimum where the depth exceeds 24 inches (610 mm).

11B-306.5.3 Beveled

Changes in level between 1/4 inch (6.4 mm) high maximum shall be permitted to be vertical and without edge treatment.

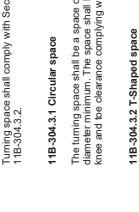
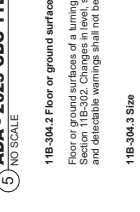
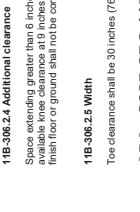
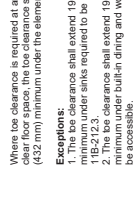
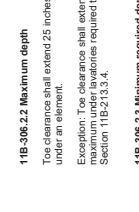
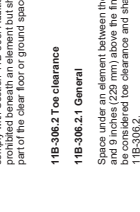
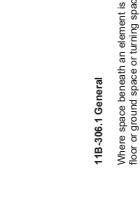
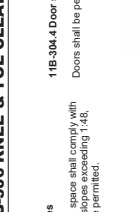
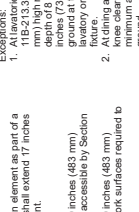
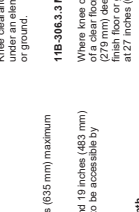
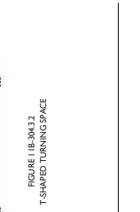
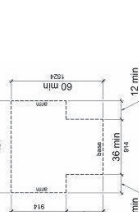
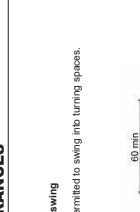
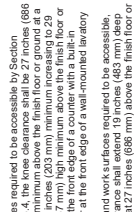
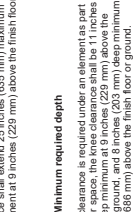
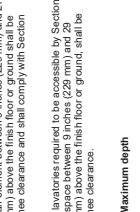
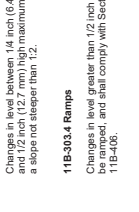
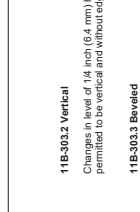
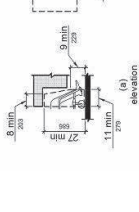
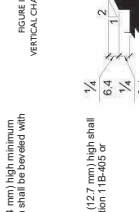
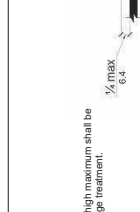
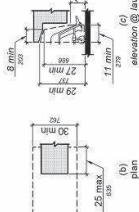
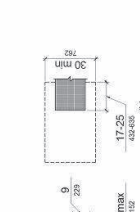
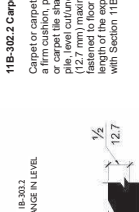
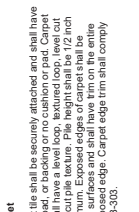
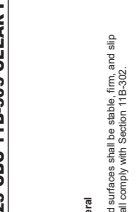
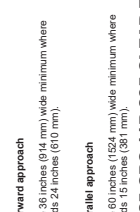
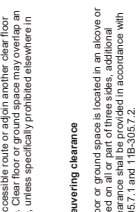
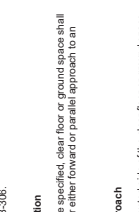
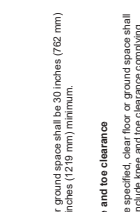
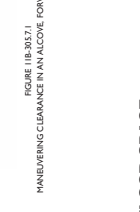
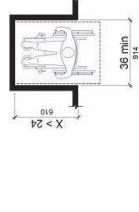
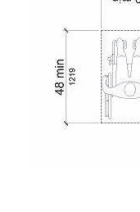
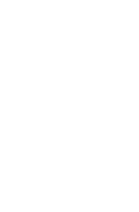
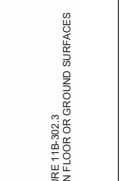
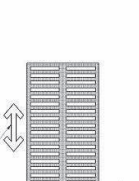
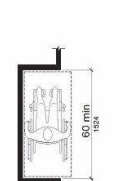
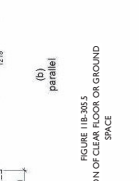
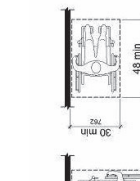



RESTROOM IMPROVEMENTS
 Salton Community Services District
 SALTON CITY PARK
 2208-2210 IRIDENCENT AVE
 THERMAL, CA 92274



44489 Town Center Way, Suite D513 Palm Desert, CA 92260 T: 760.773.0907 www.archma.com



INSTRUMENTS OF SERVICE
 I hereby certify that I am a duly Licensed Professional Engineer in the State of California, License No. 50812, and that I am duly qualified to perform the professional services herein set forth. I am duly qualified to perform the professional services herein set forth. I am duly qualified to perform the professional services herein set forth.

DATE: 01.26.2026
SHEET TITLE: ACCESSIBILITY REQUIREMENTS
SHEET NUMBER: 25-008

G201

11B-308.2 Forward reach

11B-308.2.1 Unobstructed

Where a forward reach is unobstructed, the high forward reach shall be 48 inches (1219 mm) maximum and the low forward reach shall be 15 inches (381 mm) minimum above the finish floor or ground.

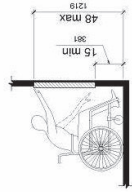

FIGURE 11B-308.2.1 UNOBSTRUCTED FORWARD REACH

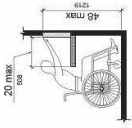

FIGURE 11B-308.2.2 OBSTRUCTED HIGH REACH

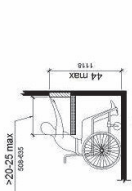

FIGURE 11B-308.2.3 OBSTRUCTED SIDE REACH

11B-308.2.2 Obstructed high reach

Where a high forward reach is over an obstruction, the clear height of the obstruction shall be 48 inches (1219 mm) maximum and the high side reach shall be 48 inches (1219 mm) maximum and the low side reach shall be 15 inches (381 mm) minimum above the finish floor or ground.

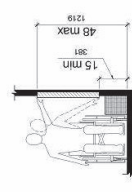

FIGURE 11B-308.2.2 UNOBSTRUCTED SIDE REACH

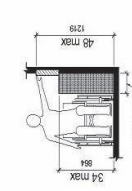

FIGURE 11B-308.2.3 UNOBSTRUCTED HIGH SIDE REACH

11B-308.3 Side reach

11B-308.3.1 Unobstructed

Where a clear floor or ground space allows a parallel approach to an element and the side reach is unobstructed, the high side reach shall be 48 inches (1219 mm) maximum and the low side reach shall be 15 inches (381 mm) minimum above the finish floor or ground.

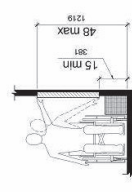

FIGURE 11B-308.3.1 UNOBSTRUCTED SIDE REACH

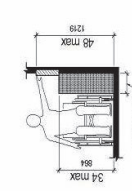

FIGURE 11B-308.3.2 UNOBSTRUCTED HIGH SIDE REACH

11B-308.3.2 Obstructed high reach

Where a clear floor or ground space allows a parallel approach to an element and the high side reach is over an obstruction, the height of the obstruction shall be 48 inches (1219 mm) maximum and the high side reach shall be 48 inches (1219 mm) maximum and the low side reach shall be 15 inches (381 mm) minimum above the finish floor or ground.

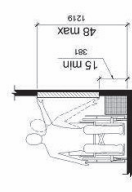

FIGURE 11B-308.3.2 UNOBSTRUCTED HIGH SIDE REACH

11B-309 Operable parts

11B-309.1 General

Operable parts shall comply with Section 11B-309.

11B-309.2 Clear floor space

A clear floor or ground space complying with Section 11B-305 shall be provided.

11B-309.3 Height

Operable parts shall be placed within one or more of the reach ranges specified in Section 11B-308.

11B-309.4 Operation

Operable parts shall be operable with one hand and shall not require tight grasping, pinching, or twisting of the wrist. The force required to activate operable parts shall be 5 pounds (22.2 N) maximum.

Exception: Gas pump nozzles and electric vehicle connectors shall not be required to provide operable parts with an activating force of 5 pounds (22.2 N) maximum.

11B-307.2 Protrusion limits

Objects with leading edges more than 27 inches (686 mm) and not more than 80 inches (2032 mm) above the finish floor or ground shall protrude 4 inches (102 mm) maximum horizontally into the circulation path.

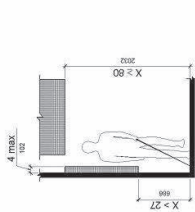

FIGURE 11B-307.2 LIMITS OF PROTRUDING OBJECTS

11B-307.4 Vertical clearance

Vertical clearance shall be 80 inches (2032 mm) high minimum. Guardrails or other barriers shall be provided where the height of the barrier is less than 80 inches (2032 mm). The leading edge of each guardrail or barrier shall be located 27 inches (686 mm) maximum above the finish floor or ground.

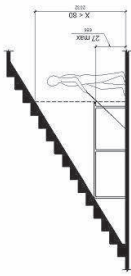

FIGURE 11B-307.4 VERTICAL CLEARANCE

11B-309 OPERABLE PARTS

(3) NO SCALE

ADA - 2025 CBC 11B-307 PROTRUDING OBJECTS

(1) NO SCALE

REVISIONS

11B-603.1 General

Toilet and bathing rooms shall comply with Section 11B-603.

11B-603.2 Clearances

Clearances shall comply with Section 11B-603.2.

11B-603.2.1 Turning space

Turning space complying with Section 11B-304 shall be provided within the room.

11B-603.2.2 Overlap

Required clear floor spaces, clearance at fixtures, and turning space shall be permitted to overlap.

11B-603.2.3 Door swing

Doors shall not swing into the clear floor space or clearance space. If doors are required to swing into the clear floor space, the swing shall be limited to the clear floor space. Other than doors to accessible water closet compartments, a door, in any position, shall be permitted to swing into the turning space by 4 inches (102 mm) maximum.

11B-603.3 Mirrors

Mirrors located above lavatories or countertops shall be located with the bottom edge of the mirror no higher than 40 inches (1016 mm) maximum above the finish floor or ground. Mirrors not located above lavatories or countertops shall be located with the bottom edge of the mirror no higher than 44 inches (1118 mm) maximum above the finish floor or ground.

11B-603.4 Coat hooks, shelves and medicine cabinets

Coat hooks shall be located within one of the reach ranges specified in Section 11B-306. Shelves shall be no higher than 40 inches (1016 mm) maximum above the finish floor. Medicine cabinets shall be located with a usable shelf no higher than 44 inches (1118 mm) maximum above the finish floor.

11B-603.5 Accessories

Where towel or sanitary napkin dispensers, waste receptacles, or other accessories are provided in toilet compartments, they shall be located with the bottom edge of the accessible route. All operable parts, including coin slots, shall be 40 inches (1016 mm) maximum above the finish floor.

11B-404.2.3 Clear width

Door openings shall provide a clear width of 32 inches (813 mm) minimum. The clear width shall be measured between the face of the door and the stop, with the door open 90 degrees. Openings more than 22 inches (559 mm) deep shall provide a clear opening of 36 inches (914 mm) minimum. The clear opening shall be measured at the required clear opening width lower than 34 inches (864 mm) above the finish floor or ground. Projections into the clear opening shall be limited to a maximum of 1/4 inch (6.35 mm) and shall not exceed 4 inches (102 mm).

11B-404.2.4 Manoeuvring clearances

Minimum manoeuvring clearances at doors and gates shall comply with Section 11B-404.2.4. Manoeuvring clearances shall extend the full width of the doorway and the required latch side or hinge side clearance.

11B-404.2.5 Thresholds

Thresholds, if provided at doorways, shall be 1/2 inch (12.7 mm) high maximum. Raised thresholds and changes in level at doorways shall comply with Sections 11B-302 and 11B-303.

11B-404.2.7 Door and gate hardware

Handles, pulls, latches, locks, and other operable parts on doors and gates shall comply with Section 11B-309.4. Operable parts shall be located with the bottom edge of the minimum and 44 inches (1118 mm) maximum above the finish floor or ground. Where sliding doors are in the fully open position, operating hardware shall be exposed and usable from both sides.

11B-404.2.9 Door and gate opening force

The force for pushing or pulling open a door or gate shall be as follows:
 1. Maximum force for hinged doors and gates: 5 pounds (22.2 N) maximum.
 2. Sliding or folding doors: 5 pounds (22.2 N) maximum.
 3. Required opening force shall be limited to the force specified by the appropriate administrative authority, but shall not exceed 15 pounds (66.7 N).
 4. Exterior hinged doors: 5 pounds (22.2 N) maximum.

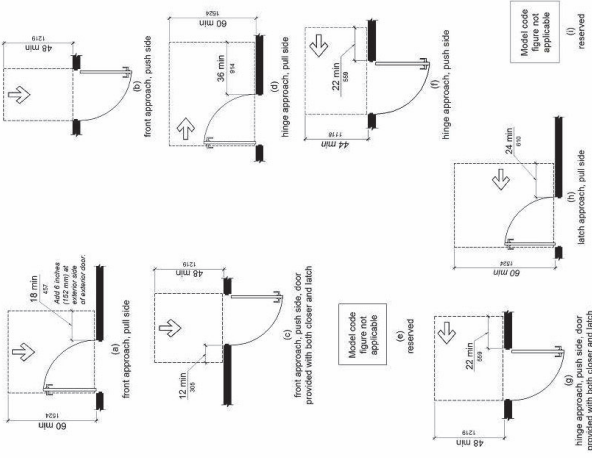

FIGURE 11B-404.2.1 MANOEUVRING CLEARANCES AT MANUAL SWINGING DOORS AND GATES

② ADA - 2025 CBC 11B-603 TOILETS
NO SCALE

① ADA - 2025 CBC 11B-404 DOORS, DOORWAYS, & GATES
NO SCALE



RESTROOM IMPROVEMENTS
 Salton Community Services District
 SALTON CITY PARK
 2208-2210 IRIDENCENT AVE
 THERMAL, CA 92274



INSTRUMENTS OF SERVICE
 I hereby certify that the above described project has been prepared by me or under my direct supervision and that I am a duly Licensed Professional Engineer in the State of California. My license number is 44517.
 I hereby certify that the above described project has been prepared by me or under my direct supervision and that I am a duly Licensed Professional Engineer in the State of California. My license number is 44517.
 I hereby certify that the above described project has been prepared by me or under my direct supervision and that I am a duly Licensed Professional Engineer in the State of California. My license number is 44517.

SHEET TITLE: **ACCESSIBILITY REQUIREMENTS**
 DATE: 01.26.2026
 MAP PROJECT NO.: 25-008
 SHEET NUMBER: 25-008
G202



RESTROOM IMPROVEMENTS
 Saltion Community Services District
 SALTION CITY PARK
 2208-2210 IRIDENCENT AVE
 THERMAL, CA 92274



INSTRUMENTS OF SERVICE
 I hereby certify that the above described work was prepared by me or under my direct supervision and that I am a duly Licensed Professional Engineer in the State of California.
 Michael J. McAuliffe
 License No. 44489
 State of California
 Date: 01/28/2026

DATE: 01/28/2026
 SHEET TITLE: ACCESSIBILITY REQUIREMENTS
 SHEET NUMBER: 25-008

G203

3 CBC 1B-403 WALKING SURFACES
 NO SCALE

Walking surfaces that are a part of an accessible route shall comply with Section 11B-403.
11B-403.2 Floor or ground surface
 Floor or ground surfaces shall comply with Section 11B-302.
11B-403.3 Slope
 The running slope of walking surfaces shall not be steeper than 1:20. The cross slope of walking surfaces shall not be steeper than 1:48.
 Exception: The running slope of sidewalks shall not exceed the general grade established for the adjacent street or highway.
11B-403.4 Changes in level
 Changes in level shall comply with Section 11B-303.

2 ADA - 2025 CBC 11B-606 LAVATORIES
 NO SCALE

11B-606.1 General
 Lavatories and sinks shall comply with Section 11B-606.
11B-606.2 Clear floor space
 A clear floor space complying with Section 11B-305, positioned for a forward approach, and knee and toe clearance complying with Section 11B-306 shall be provided.
11B-606.3 Height
 Lavatories and sinks shall be installed with the front of the higher of the rim or counter surfaces 34 inches (864 mm) maximum above the finish floor or ground.
11B-606.4 Faucets
 Controls for faucets shall comply with Section 11B-309. Hand-operated metering faucets shall remain open for 10 seconds minimum.
11B-606.5 Exposed pipe and surfaces
 Water supply and drain pipes under lavatories and sinks shall be insulated or otherwise configured to protect against condensation. There shall be no sharp or abrasive surfaces under lavatories and sinks.
11B-606.6 Adjacent side wall or partition
 Lavatories, when located adjacent to a side wall or partition, shall be a minimum of 18 inches (457 mm) to the centerline of the fixture.
11B-606.7 Sink depth
 Where a forward approach is required at a sink, knee and toe clearance shall be provided in compliance with Section 11B-306.

1 ADA - 2025 CBC 11B-604 WATER CLOSETS
 1/2" = 1'-0"

11B-604.1 General
 Water closets and toilet compartments shall comply with Sections 11B-604.2 through 11B-604.8.
11B-604.2 Location
 The water closet shall be positioned with a wall or partition to the rear of the water closet. The rear wall shall be a minimum of 17 inches (432 mm) minimum to 18 inches (457 mm) maximum from the side wall or partition, except that the water closet shall be 17 inches (432 mm) minimum and 19 inches (483 mm) maximum from the side wall or partition. The water closet shall be a minimum of 12 inches (305 mm) wide and 60 inches (1524 mm) high. The water closet shall be provided in front of the water closet.
11B-604.3 Clearances
 Clearances around water closets and in toilet compartments shall comply with Section 11B-604.3.
11B-604.3.1 Size
 Clearances around a water closet shall be 60 inches (1524 mm) minimum measured perpendicular from the side wall and 56 inches (1422 mm) minimum measured perpendicular from the rear wall. A minimum 60 inches (1524 mm) wide and 60 inches (1524 mm) high clear opening space shall be provided in front of the water closet.
11B-604.3.2 Overlap
 The required clearance around the water closet shall be 60 inches (1524 mm) minimum, except for the clearances around the water closet, dispensers, sanitary napkin disposal units, coat hooks, shelves, accessible routes, clear floor space and clearances around other fixtures. The required clearances shall be provided within the required water closet clearance.
11B-604.4 Seats
 The seat height of a water closet shall be 17 inches (432 mm) minimum and 19 inches (483 mm) maximum measured to the top of the seat. Seats shall not be sprung to return to a tilted position. Seats shall be 2 inches (51 mm) high maximum.
11B-604.5 Grab bars
 Grab bars for water closets shall comply with Section 11B-609. Grab bars shall be provided on the side wall closest to the water closet. Grab bars shall be mounted at a height of 33 inches (838 mm) above the finished floor. Grab bars are required on adjacent walls at a common mounting height, an L-shaped grab bar meeting the dimensional requirements of Sections 11B-604.5.1 and 11B-604.5.2 shall be permitted.

11B-604.7.1 Disposition units

Sanitary napkin disposal units, if provided, shall comply with Section 11B-309.4 and shall be wall mounted and located on the sidewall between the rear wall of the toilet and the toilet compartment. The disposal unit shall be located below the grab bar with the opening of the disposal unit 18 inches minimum (453 mm) above the finish floor.

11B-604.7.2 Disposition units

Sanitary napkin disposal units, if provided, shall comply with Section 11B-309.4 and shall be wall mounted and located on the sidewall between the rear wall of the toilet and the toilet compartment. The disposal unit shall be located below the grab bar with the opening of the disposal unit 18 inches minimum (453 mm) above the finish floor.

11B-604.6.2 Rear wall grab bar

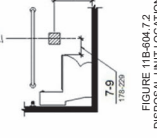

11B-604.6.4 Side wall grab bar

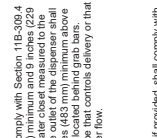

11B-604.6.5 Wheelchair accessible water closets

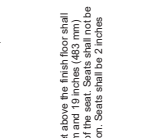

11B-604.6.7 Ambulatory accessible water closets

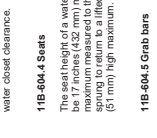

11B-604.3.1 Size

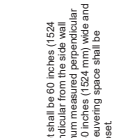

11B-604.3.2 Overlap

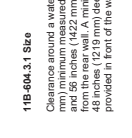

11B-604.3.1 Size

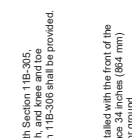

11B-604.3.2 Overlap

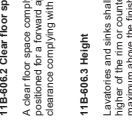

11B-604.3.1 Size

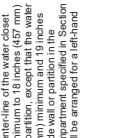

11B-604.3.2 Overlap

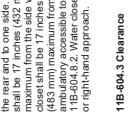

11B-604.3.1 Size



11B-604.3.2 Overlap

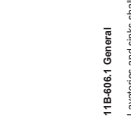

11B-604.5.1 Side wall



11B-604.5.2 Rear wall



11B-604.5.1 Side wall



11B-604.5.2 Rear wall



11B-604.5.1 Side wall



11B-604.5.2 Rear wall



11B-604.5.1 Side wall



11B-604.5.2 Rear wall



11B-604.3.1 Size



11B-604.3.2 Overlap



11B-604.3.1 Size



11B-604.3.2 Overlap



11B-604.3.1 Size



11B-604.3.2 Overlap



11B-604.3.1 Size



11B-604.3.2 Overlap



11B-604.3.1 Size of clearance at water closets



11B-604.3.1 Size of clearance at water closets



11B-604.3.1 Size of clearance at water closets



11B-604.3.1 Size of clearance at water closets



11B-604.3.1 Size of clearance at water closets



11B-604.3.1 Size of clearance at water closets



11B-604.3.1 Size of clearance at water closets



11B-604.3.1 Size of clearance at water closets



11B-604.3.1 Size of clearance at water closets



11B-604.3.1 Size of clearance at water closets



11B-604.3.1 Size of clearance at water closets



11B-604.3.1 Size of clearance at water closets





RESTROOM IMPROVEMENTS
 Salton Community Services District
 SALTON CITY PARK
 2208-2210 IRIDENCENT AVE
 THERMAL, CA 92274

McAuliffe & Co. ARCHITECTS

44-489 Town Center Way, Suite D513 Palm Desert, CA 92260 T: 760.773.0907 www.acdma.com

INSTRUMENTS OF SERVICE
 I hereby certify that I am a duly Licensed Professional Engineer in the State of California, No. 10000, and that I am the author of the above described plans and specifications. I am not providing any services in violation of the provisions of the California Professional Engineers Act, Chapter 10, Division 47, Title 16, of the California Code of Regulations, or any other applicable laws and regulations. I am not providing any services in violation of the provisions of the California Professional Engineers Act, Chapter 10, Division 47, Title 16, of the California Code of Regulations, or any other applicable laws and regulations.

Copyright © 2016, McAuliffe & Co., Inc.
 All rights reserved.

DATE: 01/26/2016
 SHEET TITLE: **DEMOLITION PLAN**
 SHEET NO.:
 PROJECT NO.:
 SHEET NUMBER: **25-008**

ADI100

1 DEMOLITION PLAN
 1/4" = 1'-0"

REVISIONS

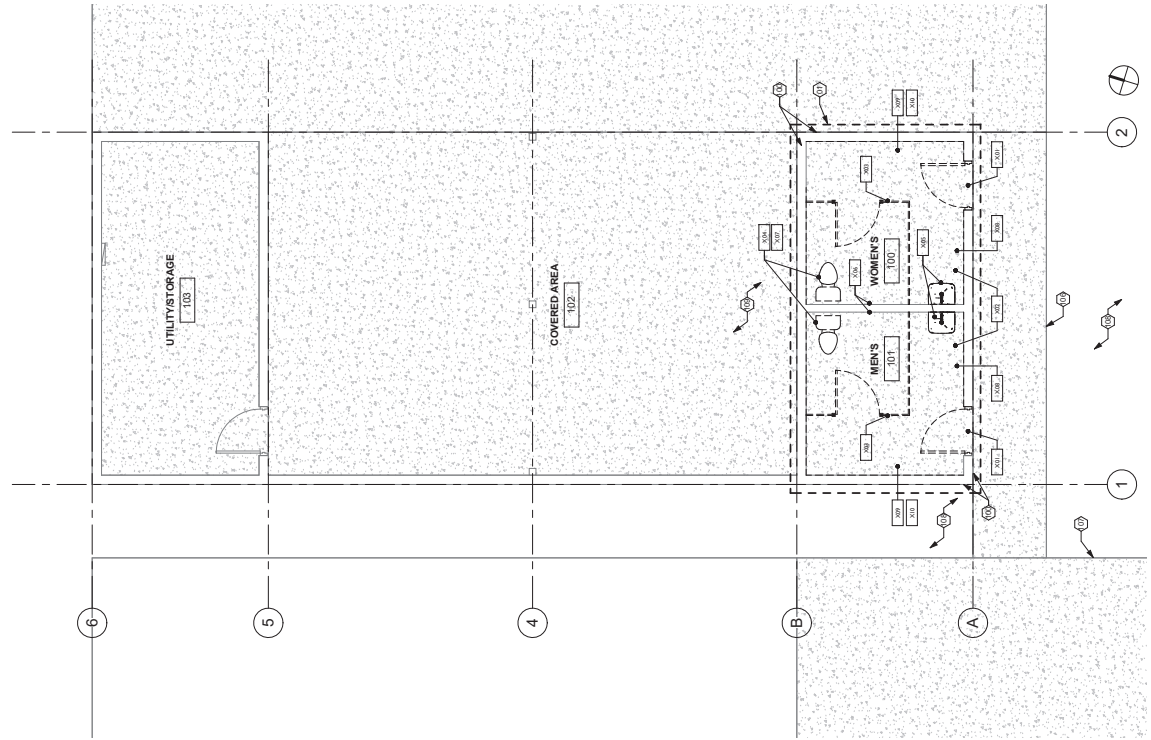

- DEMOLITION - GENERAL NOTES**
1. PROTECT EXISTING IMPROVEMENTS NOT RECEIVING WORK.
 2. ALL DEMOLITION FOR THIS PROJECT IS NON-STRUCTURAL.
 3. DEMOLITION WORK IS LIMITED TO MEN'S AND WOMEN'S RESTROOM.
 4. NO SITE DEMOLITION WORK IS A PART OF THIS PROJECT.

SHEET NOTES

NO.	DESCRIPTION
01	LIMIT OF WORK.
106	E. CONCRETE WALK.
107	E. ADA CONCRETE PARKING SPACES.
108	E. CONCRETE WALK.
109	E. CONC. SLAB.

KEYNOTES

NO.	DESCRIPTION
X01	REMOVE DOOR AND FRAME. PREP OPENING FOR NEW HM DOOR AND FRAME.
X02	REMOVE CONCRETE FLOOR SLAB. INTERIOR TO RESTROOM TYP.
X03	REMOVE TOILET PARTITION ASSEMBLY TYP.
X04	REMOVE WATER CLOSET. PREP FOR INSTALLATION OF NEW RESTROOM.
X05	REMOVE WALL-HUNG LAVATORY. PRE-PROGRAMMABLE FOR NEW PLUMBING WORK.
X06	REMOVE FINISH SURFACE. BOTH FACES. EXPOSE FRAMING FOR NEW PLUMBING WORK.
X07	REMOVE ALL WALL MOUNTED RESTROOM ACCESSORIES INCLUDING SOAP DISPENSER, PAPER TOWEL DISPENSER, ETC.
X08	REMOVE ALL WALL MOUNTED ELECTRICAL CONDUIT FOR COORDINATE SURFACE MOUNT ELECTRICAL CONDUIT FOR NEW PLUMBING WORK.
X09	REMOVE ALL ELECTRICAL PANELS WITH ELECTRICAL IMPROVEMENTS. SEE ELECTRICAL PLANS.
X10	REMOVE ALL ELECTRICAL PANELS.



2 KEY PLAN
NO SCALE

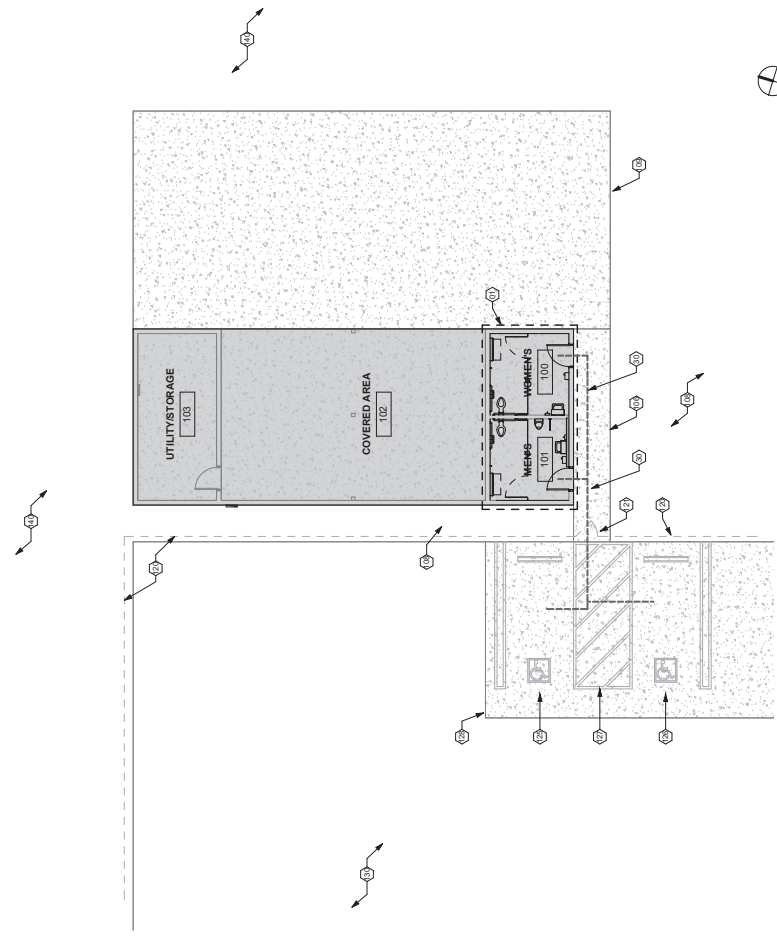

1 PARTIAL SITE PLAN
1/8" = 1'-0"

- SITE PLAN - GENERAL NOTES**
1. PROTECT EXISTING IMPROVEMENTS NOT RECEIVING WORK.
 2. PROJECT CONTAINS NO EXISTING CONDITIONED SPACE.
 3. NO CONVALESCENT SQUARE FOOTAGE IS ADDED BY THE IMPROVEMENTS OF THIS PROJECT.
 4. PARKING REQUIREMENTS ARE UNIMPACTED BY THE IMPROVEMENTS OF THIS PROJECT.
 5. PROVIDE AND MAINTAIN PROTECTIVE BARRICADE DURING COURSE OF EXTERIOR IMPROVEMENTS OF PROJECT. BARRICADE SHALL SURROUND PROJECT AREA.

SHEET NOTES

- DESCRIPTION**
- 91 ASPHALT DRIVE
 - 92 ASPHALT DRIVE TRAVEL
 - 100 E. CONCRETE WALK
 - 101 E. CONCRETE WALK
 - 102 E. CONC. SLAB
 - 103 E. CONC. SLAB
 - 104 E. CHAIN LINK FENCE
 - 105 E. ADA PARKING STALL WITH ACCESSIBLE
 - 106 E. ADA PARKING SPACE
 - 107 E. CONC. PARKING SURFACE
 - 108 E. CONC. PARKING SURFACE
 - 109 E. CONC. PARKING SURFACE
 - 110 E. CONC. PARKING SURFACE
 - 111 E. CONC. PARKING SURFACE
 - 112 E. CONC. PARKING SURFACE
 - 113 E. CONC. PARKING SURFACE
 - 114 E. CONC. PARKING SURFACE
 - 115 E. CONC. PARKING SURFACE
 - 116 E. CONC. PARKING SURFACE
 - 117 E. CONC. PARKING SURFACE
 - 118 E. CONC. PARKING SURFACE
 - 119 E. CONC. PARKING SURFACE
 - 120 E. CONC. PARKING SURFACE
 - 121 E. CONC. PARKING SURFACE
 - 122 E. CONC. PARKING SURFACE
 - 123 E. CONC. PARKING SURFACE
 - 124 E. CONC. PARKING SURFACE
 - 125 E. CONC. PARKING SURFACE
 - 126 E. CONC. PARKING SURFACE
 - 127 E. CONC. PARKING SURFACE
 - 128 E. CONC. PARKING SURFACE
 - 129 E. CONC. PARKING SURFACE
 - 130 E. CONC. PARKING SURFACE
 - 131 E. CONC. PARKING SURFACE
 - 132 E. CONC. PARKING SURFACE
 - 133 E. CONC. PARKING SURFACE
 - 134 E. CONC. PARKING SURFACE
 - 135 E. CONC. PARKING SURFACE
 - 136 E. CONC. PARKING SURFACE
 - 137 E. CONC. PARKING SURFACE
 - 138 E. CONC. PARKING SURFACE
 - 139 E. CONC. PARKING SURFACE
 - 140 E. CONC. PARKING SURFACE



RESTROOM IMPROVEMENTS
 Salton Community Services District
 SALTON CITY PARK
 2208-2210 IRIDESCANT AVE
 THERMAL, CA 92274

REVISIONS

McAuliffe & Co. ARCHITECTS

44-489 Town Center Way, Suite D513 Palm Desert, CA 92260 T: 760.773.0907 www.mca.com

INSTRUMENTS OF SERVICE
 I hereby certify that the design and construction documents shown on this sheet were prepared by me or under my direct supervision and that I am a duly licensed professional architect in the State of California. I am duly licensed in the State of California. My license number is 10000. I am duly licensed in the State of California. My license number is 10000. I am duly licensed in the State of California. My license number is 10000.

DATE: 01.26.2026
 SHEET TITLE: **SITE PLAN**
 PROJECT NO.: 25-008
 SHEET NUMBER: **A001**

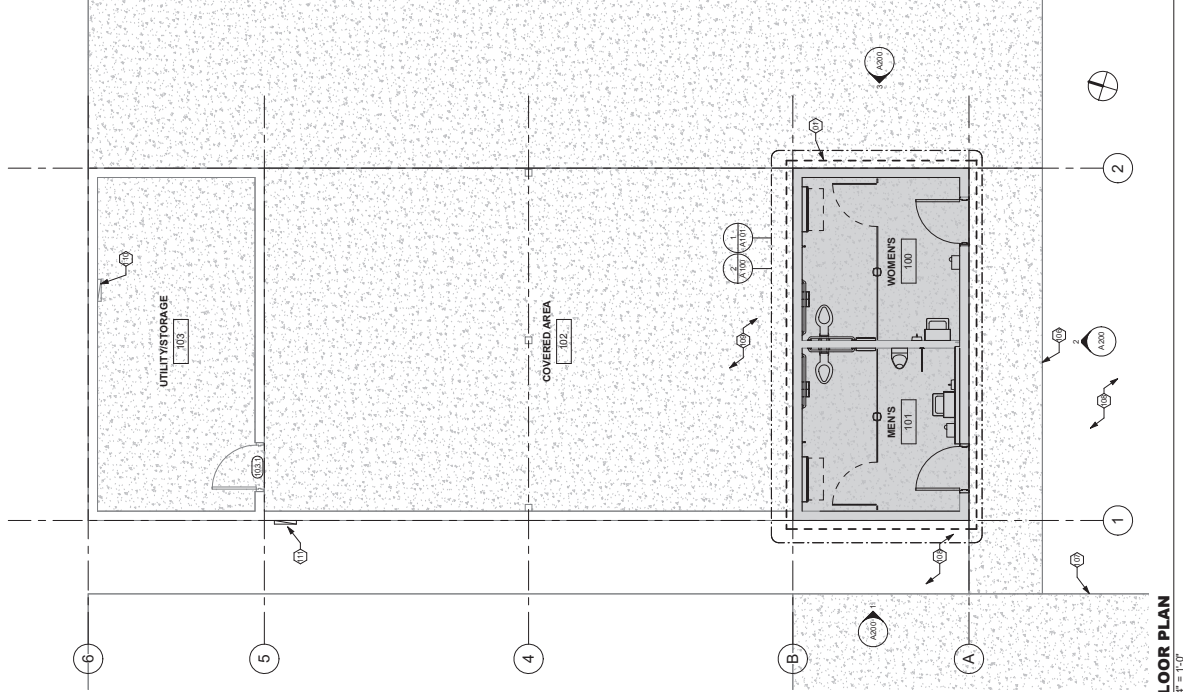

1 FLOOR PLAN
1/4" = 1'-0"

SLAB PLAN - GENERAL NOTES

1. CONCRETE SLAB TO RECEIVE HAND TROWEL FINISH
2. SLOPE CONCRETE FLOORS TO DRAIN TYP. SLOPE N.T.E. 2% IN ANY DIRECTION.
3. SEE PLUMBING PLANS FOR SUB-SLAB PLUMBING REQUIREMENTS.

SHEET NOTES

DESCRIPTION	SPEC.	DESCRIPTION
100	CONCRETE	100 E. ADA CONCRETE WALK
101	CONCRETE	101 E. ADA CONCRETE PARKING SPACES.
102	CONCRETE	102 E. ADA CONCRETE WALK
103	CONCRETE	103 E. ADA CONCRETE WALK
110	ELECTRICAL	110 E. ELECTRICAL PANEL.
111	ELECTRICAL	111 E. ELECTRICAL SERVICE.

KEYNOTES

KEY	SPEC.	DESCRIPTION
A-	SUBSTRUCTURE	A-1. SUBSTRUCTURE
		A-2. SLOPE TO DRAIN N.T.E. 2% IN ANY DIRECTION. S&L FINISH
		A-3. 6" TH. INTEGRAL CONCRETE CURB FOR NEW PARTITION PARKING

INSTRUMENTS OF SERVICE
 I hereby certify that I am a duly Licensed Professional Engineer in the State of California, License No. 44197, and that I am the author of the above described plans. I am not providing these plans for any other project, and I am not providing these plans for any other project without the written consent of the client. I am not providing these plans for any other project without the written consent of the client.



McAuliffe & Co. ARCHITECTS
 44-489 Town Center Way, Suite D513 Palm Desert, CA 92260 T: 760.773.0907 www.mcauliffe.com

REVISIONS

NO.	DESCRIPTION

RESTROOM IMPROVEMENTS
 Salton Community Services District
 SALTON CITY PARK
 2208-2210 IRIDENCENT AVE
 THERMAL, CA 92274



RESTROOMS - SLAB PLAN
 SHEET NO. 25-008

A100

FIXTURE + EQUIPMENT SCHEDULE

ID	SPEC	DESCRIPTION
FLOORING		
LAK-01		NON-SLIP MATING TILE - 18" X 18" / 1/4" THICK
LAK-02		WALL TILING URINAL WITH TOUCHLESS FLUSH VALVE
UR-01		SEE PLUMBING DRAWINGS
WC-01		SEE PLUMBING DRAWINGS
WC-02		FLOOR MOUNTED JET TOILET
WC-03		SEE PLUMBING DRAWINGS
RESTROOM ACCESSORY		
RA-01		TOILET PAPER DISPENSER
RA-02		WALL MOUNTED URINAL
RA-03		TOILET PAPER DISPENSER
RA-04		TOILET PAPER DISPENSER
RA-05		TOILET PAPER DISPENSER
RA-06		TOILET PAPER DISPENSER
RA-07		TOILET PAPER DISPENSER
RA-08		TOILET PAPER DISPENSER
RA-09		TOILET PAPER DISPENSER
RA-10		TOILET PAPER DISPENSER
RA-11		TOILET PAPER DISPENSER
RA-12		TOILET PAPER DISPENSER

ASSEMBLY SCHEDULE

ID	SPEC	DESCRIPTION
WALL PARTITION ASSEMBLY		
WP-01		NON-RATED FULL HEIGHT
WP-02		EXT. EXPOSED
WP-03		INT. EXPOSED
WP-04		NON-STRUCTURAL PARTITION - EXISTING
WP-05		NON-STRUCTURAL PARTITION - NEW
WP-06		NON-STRUCTURAL PARTITION - NEW
WP-07		NON-STRUCTURAL PARTITION - NEW
WP-08		NON-STRUCTURAL PARTITION - NEW
WP-09		NON-STRUCTURAL PARTITION - NEW
WP-10		NON-STRUCTURAL PARTITION - NEW
WP-11		NON-STRUCTURAL PARTITION - NEW
WP-12		NON-STRUCTURAL PARTITION - NEW

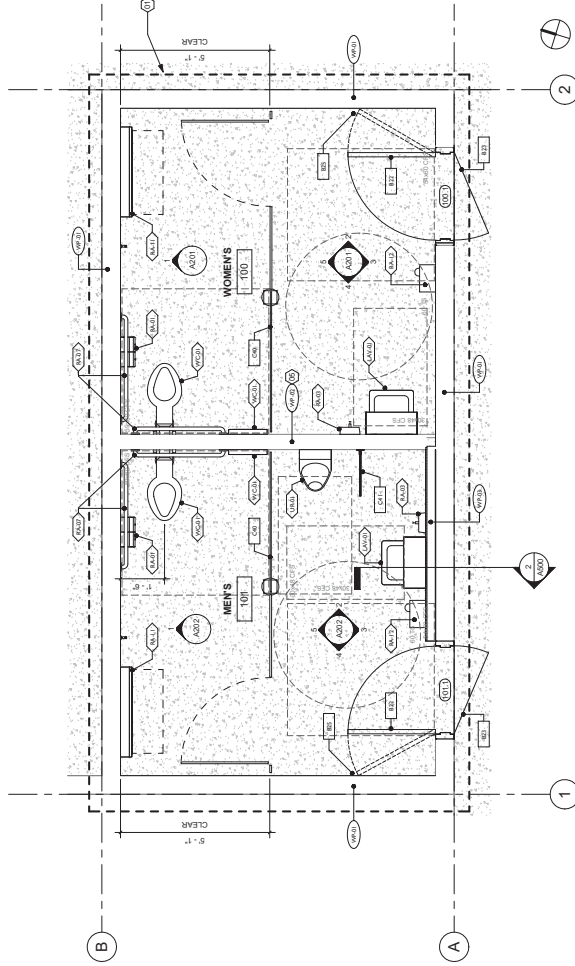

1 FLOOR PLAN - RESTROOMS
1/2" = 1'-0"

REVISIONS

INSTRUMENTS OF SERVICE
 I hereby certify that the undersigned is duly licensed as an Architect in the State of California and that the work herein is the work of the undersigned or under the direct supervision and control of the undersigned. I further certify that the work herein is the work of the undersigned or under the direct supervision and control of the undersigned.
 PROJECT NO. 25-008
 SHEET NO. RESTROOMS - FLOOR PLAN
 DATE: 01/26/2026

McAuliffe & Co. ARCHITECTS
 44489 Town Center Way, Suite D513 Palm Desert, CA 92260 T: 760.773.0907 www.mcauliffe.com

RESTROOM IMPROVEMENTS
 Salton Community Services District
 SALTON CITY PARK
 2208-2210 IRIDENCENT AVE
 THERMAL, CA 92274





RESTROOM IMPROVEMENTS
 Salton Community Services District
 SALTON CITY PARK
 2208-2210 IRIDENCENT AVE
 THERMAL, CA 92274



44-489 Town Center Way, Suite DS13 Palm Desert, CA 92260 T: 760.773.0907 www.archma.com

INSTRUMENTS OF SERVICE
 I hereby certify that I am a duly Licensed Professional Architect in the State of California and that I am the author of the design and construction documents herein. I am not providing any professional services to the project under the seal of the State of California.
 Signature: _____
 Date: _____
 Title: _____

DATE: 01/26/2026
 SHEET TITLE: **CEILING PLAN**
 PROJECT NO.: 25-008
 SHEET NUMBER: 25-008
A102

1 CEILING PLAN - RESTROOMS
 1/2" = 1'-0"

REVISIONS

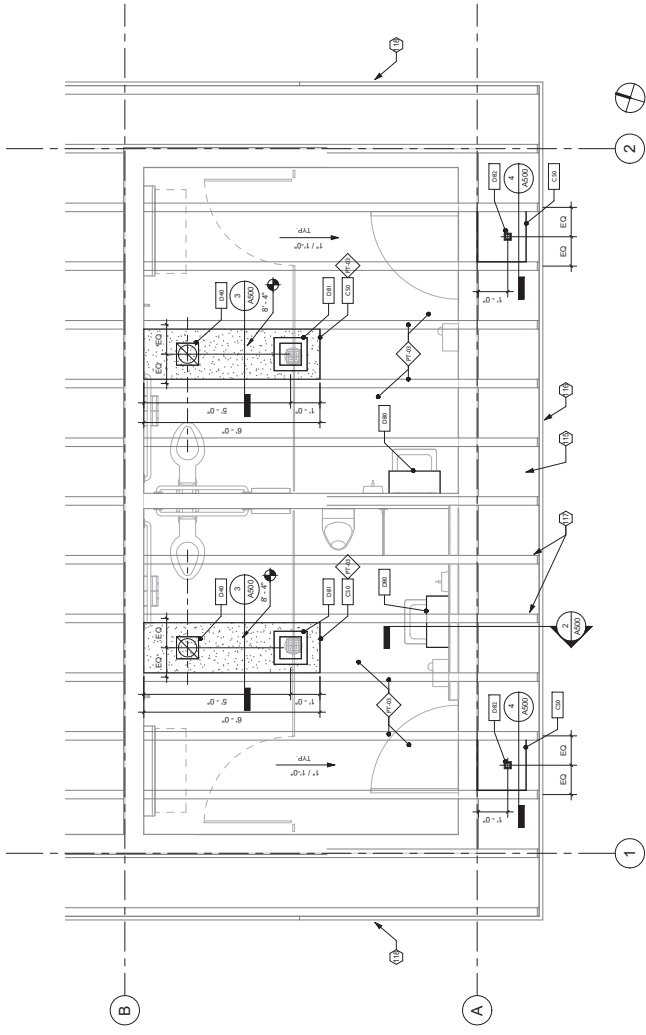

FINISHES SCHEDULE

FINISH	DESCRIPTION
P403	PAINT MIRR-DUNN EDWARDS (OR EQUAL) PRIMER SHEEN: EGGSHELL COATS: 2

- CEILING PLAN - GENERAL NOTES**
1. PROTECT EXISTING IMPROVEMENTS NOT RECEIVING WORK.
 2. PREP AND PAINT ALL EXPOSED INTERIOR CEILING SURFACES TYP.
 3. SEE THE DRAWING FOR ADDITIONAL INFORMATION AND REQUIREMENTS.

SHEET NOTES

ID	DESCRIPTION
115	E. ROOF OVERHANG.
116	E. FASCIA.
117	E. RAFTERS AT 24" O.C.
118	E. WOOD FASCIA RAFT.

KEYNOTES

ID	SPEC	DESCRIPTION
C	INTERIORS	C-08 061000 <=RSP
D	SERVICES	CONDUIT FOR SEE ELECTRICAL LED LIGHTING FIXTURES LED LIGHTING FIXTURES SURFACE MOUNT LED LIGHTING, MOUNT TO FURRED DOWN VANDAL-RESISTANT, RECESSED DOWNLIGHT, CONNECT TO THE CLOCK.
DB1		
DB2		

FINISHES SCHEDULE

ID	SPEC DESCRIPTION
MF-01	CERAMIC TILE COVE BASE SERIES: PORTFOLIO COLOR: 30027 "MUSEUM" CONTOUR: 90° "CHARCOAL" DETAIL: A470 MFR: WALTER (OR EQUAL) MFR: WALTER (OR EQUAL) FINISH: POLISHED GLOSS TEXTURE: PATTERNED DETAIL: A470
MF-02	MFR: DUNN EDWARDS (OR EQUAL) COLOR: 10027 "MUSEUM" CONTS: 2 MFR: DUNN EDWARDS (OR EQUAL) SHEEN: SEMI-GLOSS CONTS: 2 MFR: DUNN EDWARDS (OR EQUAL) SHEEN: SEMI-GLOSS CONTS: 2
MF-03	MFR: DUNN EDWARDS (OR EQUAL) COLOR: 10027 "MUSEUM" CONTS: 2 MFR: DUNN EDWARDS (OR EQUAL) SHEEN: SEMI-GLOSS CONTS: 2

FIXTURE • EQUIPMENT SCHEDULE

ID	SPEC DESCRIPTION
TP-01	TOILET PARTITION MFR: HANSON (OR EQUAL) SERIES: STANDARD SERIES OF COLOR: 915 "COOL" OTHER: FLOOR MOUNT • HEAVY BRAZED
UB-01	URINAL MFR: HANSON (OR EQUAL) SERIES: STANDARD SERIES OF TYPE: HOPE SOLID PLASTIC FINISH: POLISHED GLOSS OTHER: WALL MOUNT
PL-01	PLUMBING WALL MOUNT LAVATORY • FAUCET ADA COMPLIANT SEE PLUMBING DRAWINGS
UR-01	URINAL MFR: HANSON (OR EQUAL) SERIES: STANDARD SERIES OF TYPE: HOPE SOLID PLASTIC FINISH: POLISHED GLOSS OTHER: WALL MOUNT
WC-01	W.C. ACCESSORY SEE PLUMBING DRAWINGS

5 MEN'S NORTH - PARTITION
1/2" = 1'-0"

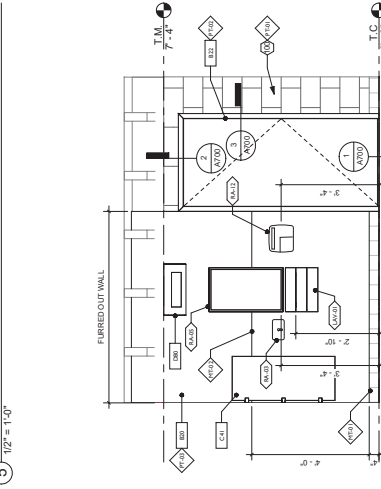

4 MEN'S WEST
1/2" = 1'-0"

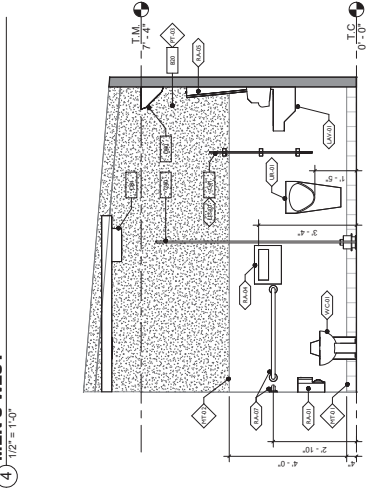

3 MEN'S SOUTH
1/2" = 1'-0"

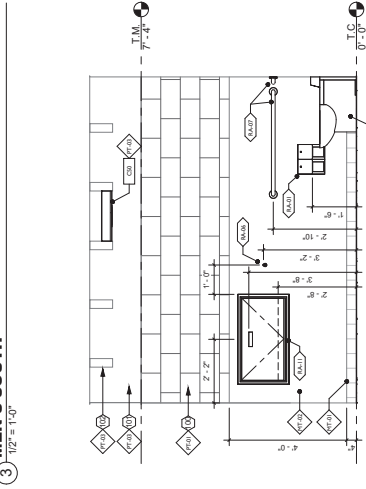

2 MEN'S EAST
1/2" = 1'-0"



1 MEN'S NORTH
1/2" = 1'-0"

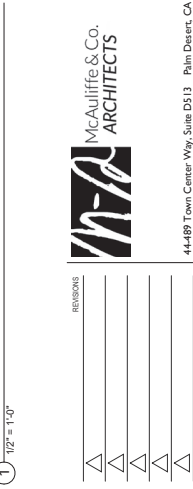

RESTROOM IMPROVEMENTS
Salton Community Services District
SALTON CITY PARK
2208-2210 IRIDENCENT AVE
THERMAL, CA 92274

McAuliffe & Co. ARCHITECTS



INSTRUMENTS OF SERVICE
I hereby certify that I am a duly Licensed Architect in the State of California, No. 10000, and that I am the author of the above described plans, specifications and contract documents. My commission expires on 12/31/2024.
I am duly Licensed in the State of California, No. 10000, and that I am the author of the above described plans, specifications and contract documents. My commission expires on 12/31/2024.
I am duly Licensed in the State of California, No. 10000, and that I am the author of the above described plans, specifications and contract documents. My commission expires on 12/31/2024.

REVISIONS

DATE: 01.26.2026
SHEET TITLE: INTERIOR ELEVATIONS
PROJECT NO: MEN'S RESTROOM
SHEET NUMBER: 25-008

INSTRUMENTS OF SERVICE
I hereby certify that I am a duly Licensed Architect in the State of California, No. 10000, and that I am the author of the above described plans, specifications and contract documents. My commission expires on 12/31/2024.
I am duly Licensed in the State of California, No. 10000, and that I am the author of the above described plans, specifications and contract documents. My commission expires on 12/31/2024.
I am duly Licensed in the State of California, No. 10000, and that I am the author of the above described plans, specifications and contract documents. My commission expires on 12/31/2024.



McAuliffe & Co. ARCHITECTS

REVISIONS

44489 Town Center Way, Suite D513 Palm Desert, CA 92260 T: 760.773.0907 www.archma.com

RESTROOM IMPROVEMENTS
Salton Community Services District
SALTON CITY PARK
2208-2210 IRIDENCENT AVE
THERMAL, CA 92274



- INTERIOR ELEVATION - GENERAL NOTES**
- PROTECT EXISTING IMPROVEMENTS NOT RECEIVING WORK.
 - PREPARE WALL AND CEILING SURFACES FOR REPAIRING.
 - ALL FIXTURES AND RESTROOM ACCESSORIES TO BE INSTALLED TO COMPLY WITH ADA ACCESSIBILITY STANDARDS TYP. SEE C200 SHEETS FOR ADDITIONAL INFORMATION AND REQUIREMENTS.
 - SEE PRE-DRAWINGS FOR ADDITIONAL INFORMATION AND REQUIREMENTS.

SHEET NOTES

ID	SPEC DESCRIPTION
00	E. CEM. WALL.
100	E. T111 SMOOTH PAINT
105	E. 6" X 6" X 1/2" PAINTERS PAINT.

KEYNOTES

ID	SPEC DESCRIPTION
B-SHELL	5/8" O.P. 80-LEVEL 4 SMOOTH PAINT
B20	H.DOORS & FRAME PAINT FINISH-ALL EXPOSED SURFACES
C-INTERIORS	METAL TOILET PARTITION
C40	FURRED-DOWN 2x4 CEILING FRAMING W/ 9/16" DRYWALL FINISH- SURFACE FOR NEW SURFACE MOUNT LUMINAIRE
C50	081000
D-SERVICES	LED LAVATORY VANITY FIXTURE SEE ELECTRICAL
D80	SURFACE MOUNT LED LUMINAIRE MOUNT TO FURRED-DOWN CEILING FRAMING SEE ELEC. TRADE.
D81	

A202

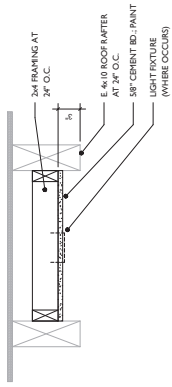

4 1 1/2" = 1'-0"

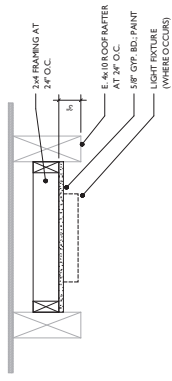

3 1 1/2" = 1'-0"

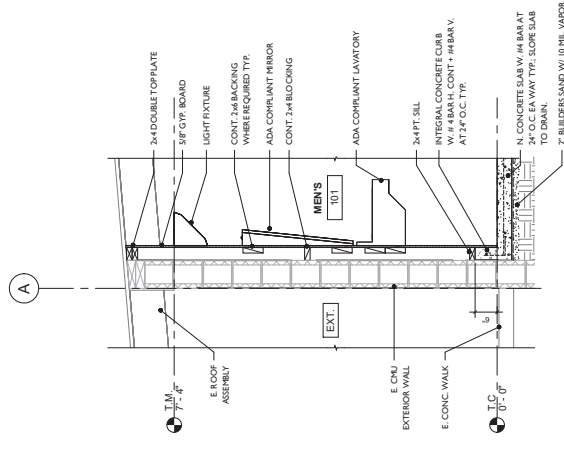

2 3/8" = 1'-0"

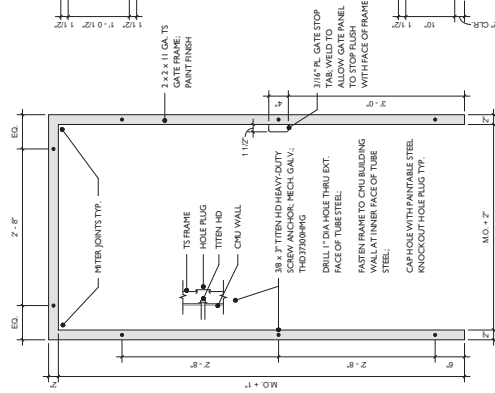

1 1" = 1'-0"

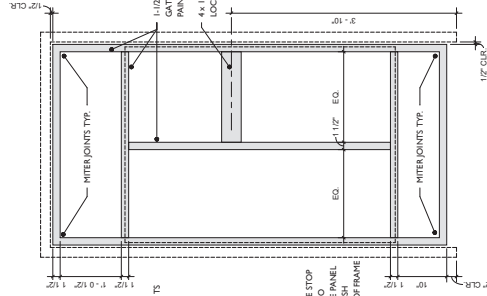

GATE PANEL FRAME

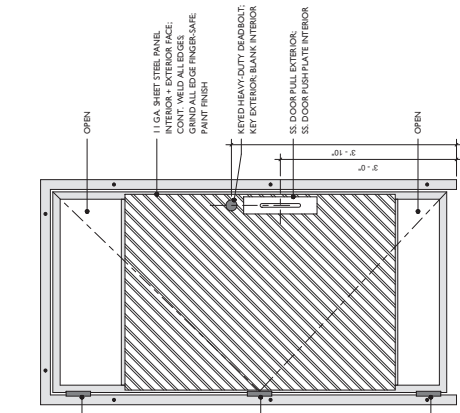

ASSEMBLY

- NOTES:
- ALL JOINTS TO BE WELDED AND GROUND SMOOTH.
 - SEE A01 FLOOR PLAN FOR GATE SPRING DIRECTION.

REVISIONS



INSTRUMENTS OF SERVICE
 I hereby certify that I am a duly Licensed Professional Engineer in the State of California, License No. 45678, and that I am the author of the above described plans and specifications. I am not providing these plans and specifications for any other project or for any other use without the written consent of the client. My professional seal is a true and correct representation of my status as a Professional Engineer in the State of California.
 Michael J. McAuliffe
 Professional Engineer
 License No. 45678
 State of California

44-489 Town Center Way, Suite D513 Palm Desert, CA 92260 T: 760.773.0907 www.archma.com

RESTROOM IMPROVEMENTS
 Salton Community Services District
 SALTON CITY PARK
 2208-2210 IRIDENCENT AVE
 THERMAL, CA 92274



SHEET TITLE: **BUILDING DETAILS**
 DATE: 01.26.2026
 PROJECT NO: 25-008

A500

DOOR SCHEDULE

MARK	DESCRIPTION	TYPE	WIDTH	HEIGHT	MATERIAL	THICK.	FINISH	FRAME MATL.	FRAME FIN.	GLAZING	FIRE RATING	U-FACTOR	SHGC	HARDWARE GROUP	REMARKS
1001	INDOOR ENTRANCE	A	2'-0"	6'-8"	1M	0'-1.134"	PAINT	1M	PAINT	-	N/A	-	-	01	RESTROOM ENTRANCE ADA ACCESSIBLE TO RECEIVE ADA ACCESSIBLE SIGNAGE
1011	INDOOR ENTRANCE	A	2'-0"	6'-8"	1M	0'-1.134"	PAINT	1M	PAINT	-	N/A	-	-	01	RESTROOM ENTRANCE ADA ACCESSIBLE TO RECEIVE ADA ACCESSIBLE SIGNAGE
1021	DOOR ENTRANCE	-	2'-0"	6'-8"	SC-100	0'-1.134"	ESF1	100	ESF1	-	N/A	-	-	ESF1	DOOR ENTRANCE WORK

DOOR - GENERAL NOTES

1. PROTECT EXISTING IMPROVEMENTS NOT RECEIVING WORK.
2. CONTRACTOR TO VERIFY EXISTING MASONRY OPENINGS AT RESTROOM DOORS TO ENSURE OPENING WILL ACCOMMODATE AN ADA COMPLIANT DOOR + HI FRAME.
3. ALL DOOR HARDWARE PROVIDED IS BASE-OF-DESIGN FOR FUNCTION AND LEVEL OF QUALITY. EQUAL SUBSTITUTIONS ARE ACCEPTABLE.
4. PER OWNER, RESTROOM DOORS ARE INTENDED TO BE LOCKED IN THE OPEN POSITION DURING HOUR OF PARK OPERATION. DOORS TO BE SECURED OPEN WITH SECURITY HASP AND PADLOCK. SEE HI/FI FLOOR PLAN.
5. RESTROOM PRIVACY TO BE MAINTAINED BY NON-LATCHING SECURITY GATE WITH PRIVACY PANEL. SEE DETAIL 1A300.

DOOR HARDWARE

GROUP	HINGES	LOCKS/LATCHES	AUX LOCKS	EXIT DEVICES	LOCK CYLINDERS	OPERATING TRIM	CLOSERS	DOOR GASKETING	THRESHOLD	AUX. DOOR HARDWARE
SET 01	QTY: (1) PER LEAF ITEM 2040BOLT REMARKS: 3/8" DIA. HEAVY WEIGHT FINISH: 636	N/A	ITEM 2040BOLT REMARKS: KEYS EXTENDED EXTERIOR, THUMB TURN INTERIOR FINISH: 636	N/A	SPEC PERMANENT CORE AMERICA COLLUM	FULL PLATE MFR: ROCKWOOD J11 X 70 REMARKS: ADA ACCESSIBLE FINISH: HL ALUMI QTY: (1) MFR: ROCKWOOD TPE FINISH: HL ALUMI LOCK PLATE QTY: (2) MFR: ROCKWOOD K1 (123) X 12" H FINISH: HL ALUMI DOOR BOTTOM QTY: (1) MFR: ROCKWOOD K1 (123) X 12" H REMARKS: ADA ACC. FINISH: HL ALUMI	N/A	QTY: (1) SET MFR: ROCKWOOD J11 X 70 REMARKS: PERMETER GASKETING FINISH: BLACK	QTY: (1) MFR: 718 REMARKS: COMMERCIAL SADDLE THRESHOLD - ADA COMPLIANT FINISH: HL ALUMI	DOOR STOP QTY: (1) MFR: ROCKWOOD 44 OR EQUAL REMARKS: HIGH DOME STOP FINISH: 636 SECURITY HASP QTY: (1) MFR: 636 OR EQUAL MODEL: 7-4" HEAVY DUTY STEEL BAR SECURITY HASP MFR: 636 OR EQUAL DOOR OPEN LOCKS: RESTROOM DOOR OPEN LOCKS: HOUSE OF OPERATION

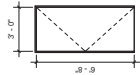

FLUSH PANEL

DOOR TYPES

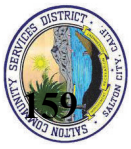

RESTROOM IMPROVEMENTS
Salton County Community Services District
SALTON CITY PARK
2208-2210 IRIDENCECENT AVE
THERMAL, CA 92274



44489 Town Center Way, Suite D513 Palm Desert, CA 92260 T: 760.773.0907 www.archma.com



INSTRUMENTS OF SERVICE
McAuliffe & Co., Inc. is a professional corporation. The undersigned is duly licensed and qualified to practice architecture in the State of California. I have prepared the above drawings and specifications for the project described herein and I am a duly licensed and qualified architect in the State of California. I have prepared the above drawings and specifications in accordance with the provisions of the California State Board of Architecture and the California State Board of Professional Engineers and Land Surveyors. I have prepared the above drawings and specifications in accordance with the provisions of the California State Board of Architecture and the California State Board of Professional Engineers and Land Surveyors. I have prepared the above drawings and specifications in accordance with the provisions of the California State Board of Architecture and the California State Board of Professional Engineers and Land Surveyors.

DATE: 01.26.2026
SHEET TITLE: SCHEDULES
SHEET NUMBER: 25-008

A600

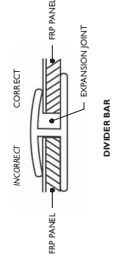
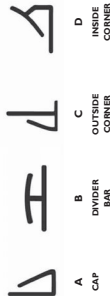

FRP EXPANSION JOINT SCHEDULE

FRP PANEL	EXPANSION JOINT	FRP PANEL	EXPANSION JOINT
48"	4x10"	48"	4x10"
60"	1x4"	60"	3x8"
72"	1x4"	72"	3x8"
84"	1x4"	84"	3x8"
96"	1x4"	96"	3x8"
108"	1x4"	108"	3x8"
120"	1x4"	120"	3x8"

NOTE: SPACING FRP MANUFACTURER'S INSTRUCTIONS FOR EXPANSION AND CONTRACTION. FAILURE TO ALLOW ADEQUATE MOLDING SPACING MAY CAUSE DELAMINATION.

DETAIL - FRP WALL PANEL SYSTEM

5 NO SCALE

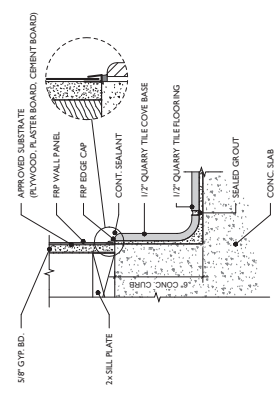

DETAIL - TILE COVE BASE

4 NO SCALE

RESTROOM IMPROVEMENTS
 Salton Community Services District
 SALTON CITY PARK
 2208-2210 IRIDENCENT AVE
 THERMAL, CA 92274

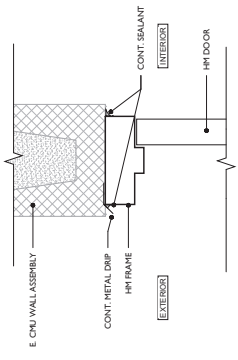
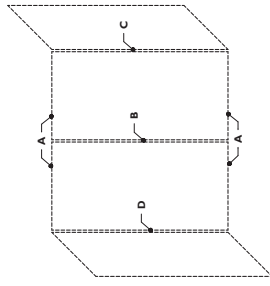

DETAIL - HH DOOR HEAD

2 3" = 1'-0"

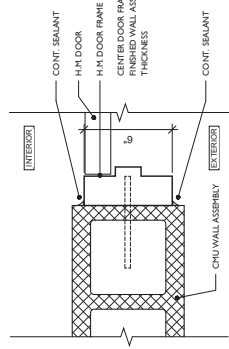

DETAIL - HH DOOR JAMB

3 3" = 1'-0"

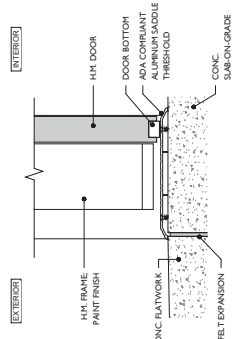

DETAIL - HH DOOR THRESHOLD

1 3" = 1'-0"

REVISIONS



44489 Town Center Way, Suite D513 Palm Desert, CA 92260 T: 760.773.0907 www.archma.com

DATE: 01.28.2026
 SHEET TITLE: STANDARD DETAILS
 SHEET NUMBER: 25-008

INSTRUMENTS OF SERVICE
 I hereby certify that I am a duly Licensed Professional Engineer in the State of California, License No. 44227, and that I am the author of the design and drawings herein. I am not providing these drawings for use in any other project without my written consent. I am not providing these drawings for use in any other project without my written consent. I am not providing these drawings for use in any other project without my written consent.

A700

USA



WALL MOUNTED and FLOOR MOUNTED
Solid Plastic Urinal Screens

Material Specification

1.1.1 CONSTRUCTION

Standard screen for wall mounted urinals. Manufactured from extruded polypropylene with a high impact polystyrene (HIPS) face. The screen is designed to be mounted on a wall or floor with a minimum clearance of 1/2" (13mm) from the urinal. The screen is designed to be used with a standard urinal.

1.1.2 WALL MOUNTED SCREENS

Standard screen for wall mounted urinals. Manufactured from extruded polypropylene with a high impact polystyrene (HIPS) face. The screen is designed to be mounted on a wall with a minimum clearance of 1/2" (13mm) from the urinal. The screen is designed to be used with a standard urinal.

1.1.3 FLOOR MOUNTED SCREENS

Standard screen for floor mounted urinals. Manufactured from extruded polypropylene with a high impact polystyrene (HIPS) face. The screen is designed to be mounted on a floor with a minimum clearance of 1/2" (13mm) from the urinal. The screen is designed to be used with a standard urinal.

1.1.4 HARDWARE & FINISHES

Hardware and finishes are available in a variety of colors and finishes. Contact your distributor for more information.

1.1.5 FINISH

Standard finish is a high impact polystyrene (HIPS) face. Other finishes are available upon request.



Hadrian Manufacturing, Inc. 10000 South Main Street, Suite 100, Dallas, TX 75241
www.hadrian-inc.com



WALL MOUNTED and FLOOR MOUNTED
Solid Plastic Urinal Screens

Material Specification

1.1.1 CONSTRUCTION

Standard screen for wall mounted urinals. Manufactured from extruded polypropylene with a high impact polystyrene (HIPS) face. The screen is designed to be mounted on a wall or floor with a minimum clearance of 1/2" (13mm) from the urinal. The screen is designed to be used with a standard urinal.

1.1.2 WALL MOUNTED SCREENS

Standard screen for wall mounted urinals. Manufactured from extruded polypropylene with a high impact polystyrene (HIPS) face. The screen is designed to be mounted on a wall with a minimum clearance of 1/2" (13mm) from the urinal. The screen is designed to be used with a standard urinal.

1.1.3 FLOOR MOUNTED SCREENS

Standard screen for floor mounted urinals. Manufactured from extruded polypropylene with a high impact polystyrene (HIPS) face. The screen is designed to be mounted on a floor with a minimum clearance of 1/2" (13mm) from the urinal. The screen is designed to be used with a standard urinal.

1.1.4 HARDWARE & FINISHES

Hardware and finishes are available in a variety of colors and finishes. Contact your distributor for more information.

1.1.5 FINISH

Standard finish is a high impact polystyrene (HIPS) face. Other finishes are available upon request.



Hadrian Manufacturing, Inc. 10000 South Main Street, Suite 100, Dallas, TX 75241
www.hadrian-inc.com

TP-2



Headrail Based
STANDARD
Solid Plastic Toilet Partitions

Material Specification

1.1.1 CONSTRUCTION

Standard partition for wall mounted urinals. Manufactured from extruded polypropylene with a high impact polystyrene (HIPS) face. The partition is designed to be mounted on a wall or floor with a minimum clearance of 1/2" (13mm) from the urinal. The partition is designed to be used with a standard urinal.

1.1.2 WALL MOUNTED PARTITIONS

Standard partition for wall mounted urinals. Manufactured from extruded polypropylene with a high impact polystyrene (HIPS) face. The partition is designed to be mounted on a wall with a minimum clearance of 1/2" (13mm) from the urinal. The partition is designed to be used with a standard urinal.

1.1.3 FLOOR MOUNTED PARTITIONS

Standard partition for floor mounted urinals. Manufactured from extruded polypropylene with a high impact polystyrene (HIPS) face. The partition is designed to be mounted on a floor with a minimum clearance of 1/2" (13mm) from the urinal. The partition is designed to be used with a standard urinal.

1.1.4 HARDWARE & FINISHES

Hardware and finishes are available in a variety of colors and finishes. Contact your distributor for more information.

1.1.5 FINISH

Standard finish is a high impact polystyrene (HIPS) face. Other finishes are available upon request.



Hadrian Manufacturing, Inc. 10000 South Main Street, Suite 100, Dallas, TX 75241
www.hadrian-inc.com



Headrail Based
STANDARD
Solid Plastic Toilet Partitions

Material Specification

1.1.1 CONSTRUCTION

Standard partition for wall mounted urinals. Manufactured from extruded polypropylene with a high impact polystyrene (HIPS) face. The partition is designed to be mounted on a wall or floor with a minimum clearance of 1/2" (13mm) from the urinal. The partition is designed to be used with a standard urinal.

1.1.2 WALL MOUNTED PARTITIONS

Standard partition for wall mounted urinals. Manufactured from extruded polypropylene with a high impact polystyrene (HIPS) face. The partition is designed to be mounted on a wall with a minimum clearance of 1/2" (13mm) from the urinal. The partition is designed to be used with a standard urinal.

1.1.3 FLOOR MOUNTED PARTITIONS

Standard partition for floor mounted urinals. Manufactured from extruded polypropylene with a high impact polystyrene (HIPS) face. The partition is designed to be mounted on a floor with a minimum clearance of 1/2" (13mm) from the urinal. The partition is designed to be used with a standard urinal.

1.1.4 HARDWARE & FINISHES

Hardware and finishes are available in a variety of colors and finishes. Contact your distributor for more information.

1.1.5 FINISH

Standard finish is a high impact polystyrene (HIPS) face. Other finishes are available upon request.



Hadrian Manufacturing, Inc. 10000 South Main Street, Suite 100, Dallas, TX 75241
www.hadrian-inc.com

REVISIONS

RESTROOM IMPROVEMENTS
Salton Community Services District
SALTON CITY PARK
2208-2210 IRIDENSCENT AVE
THERMAL, CA 92274



McAuliffe & Co. ARCHITECTS
44489 Town Center Way, Suite D513 Palm Desert, CA 92260 T: 760.773.0907 www.acma.com

INSTRUMENTS OF SERVICE
McAuliffe & Co. Architects, Inc. is pleased to provide these instruments of service to the client. The client is responsible for the design and construction of the project. The client is responsible for the design and construction of the project. The client is responsible for the design and construction of the project.

DATE: 01/26/2026
SHEET TITLE: MANUFACTURER DETAILS
SHEET NUMBER: 25-008
PROJECT NO: A702

- GENERAL NOTES:**
1. AIR INTAKE AND EXHAUST POINTS SHALL BE SEPARATED BY 4' MIN.
 2. EXHAUST POINTS TO BE LOCATED AT LEAST 10' FROM BUILDING FACE.
 3. EXHAUST POINTS TO BE LOCATED AT LEAST 10' FROM OTHER EXHAUST POINTS.
 4. EXHAUST POINTS TO BE LOCATED AT LEAST 10' FROM AIR INTAKE POINTS.
- KEYNOTES:**
1. EXHAUST POINTS TO BE LOCATED AT LEAST 10' FROM BUILDING FACE.
 2. EXHAUST POINTS TO BE LOCATED AT LEAST 10' FROM OTHER EXHAUST POINTS.
 3. EXHAUST POINTS TO BE LOCATED AT LEAST 10' FROM AIR INTAKE POINTS.

VENTILATION SCHEDULE CEC 2025

ROOM NUMBER	ROOM NAME	OCCUPANT CLASSIFICATION	FLOOR AREA (SQ FT)	EXHAUST POINTS	MINIMUM OCCUPANT FRESH AIR (CFM)		TOTAL FRESH AIR (CFM)		EXHAUST POINTS (CFM)		ACTUAL (CFM)		EQUIPMENT	
					PER PERSON	PER AREA	PER PERSON	PER AREA	PER PERSON	PER AREA	PER PERSON	PER AREA	PER PERSON	PER AREA
10	MEANS	MEANS	10	1	1	1	1	1	1	1	1	1	1	1
11	MEANS	MEANS	11	1	1	1	1	1	1	1	1	1	1	1
TOTALS														

TAG	SERVICE	CHL	WTR	EHP	WTR	V	PH	HZ	WGT	LBS	MANUFACTURER	MODEL NO.	REMARKS
1	MEANS	1	1	1	1	1	1	1	1	1	1	1	1
2	MEANS	2	2	2	2	2	2	2	2	2	2	2	2

- REMARKS:**
1. MEANS ROOMS SHALL BE VENTILATED BY MEANS OF MEANS ROOMS.
 2. MEANS ROOMS SHALL BE VENTILATED BY MEANS OF MEANS ROOMS.
 3. MEANS ROOMS SHALL BE VENTILATED BY MEANS OF MEANS ROOMS.
 4. MEANS ROOMS SHALL BE VENTILATED BY MEANS OF MEANS ROOMS.

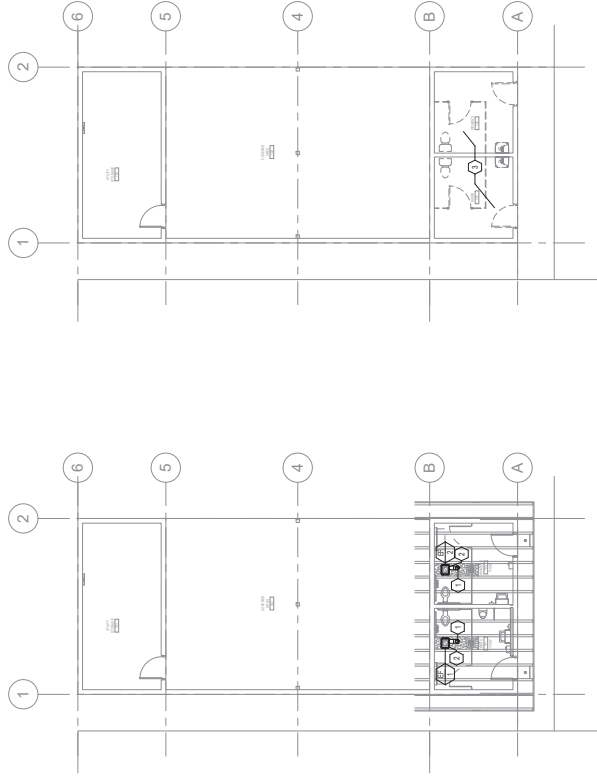
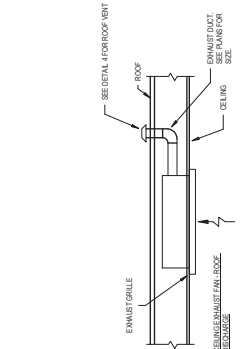
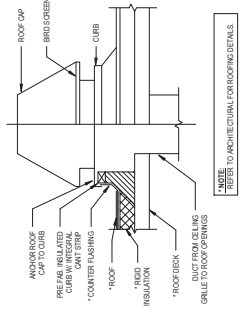

DATE: 01.28.24
SHEET TITLE: MECHANICAL PLANS
SHEET NUMBER: 25-008
PROJECT NUMBER: 25-008

INSTRUMENTS OF SERVICE
McAuliffe & Co. ARCHITECTS
44-89 Town Center Way, Suite D513, Palm Desert, CA 92260
T: 760.773.0907 | www.mcauliffe.com

REVISIONS:
01/28/2024
PERMIT
REVISIONS:
01/28/2024

McAuliffe & Co. ARCHITECTS
44-89 Town Center Way, Suite D513, Palm Desert, CA 92260
T: 760.773.0907 | www.mcauliffe.com

rtm
engineering consultants
2208-2210 IRIDENICIENT AVE
THERMAL, CA 92274

RESTROOM IMPROVEMENTS
Salton Community Services District
2208-2210 IRIDENICIENT AVE
THERMAL, CA 92274



MI00



RESTROOM IMPROVEMENTS
 Salton Community Services District
 SALTON CITY PARK
 2208-2210 IRIDENCENT AVE
 THERMAL, CA 92374



REVISIONS
 01/28/2026
 PERMIT
 01/28/2026



44-89 Town Center Way, Suite D513 Palm Desert, CA 92260 T: 760.773.0907 www.warchm.com

DATE: 01.28.26
 INSTRUMENTS OF SERVICE
 25-008
 SHEET TITLE: PLUMBING LEGEND
 SHEET NUMBER: P000

PLUMBING ENERGY NOTES:

1. PROVIDE ENERGY EFFICIENT WATER SUPPLY TO WATER HEATERS (HEAT TRAP TRAP) IN ALL CONNECTIONS & PARKING RETURN BRANCH
2. PROVIDE ENERGY EFFICIENT WATER SUPPLY TO WATER HEATERS (HEAT TRAP TRAP) IN ALL CONNECTIONS & PARKING RETURN BRANCH
3. PROVIDE ENERGY EFFICIENT WATER SUPPLY TO WATER HEATERS (HEAT TRAP TRAP) IN ALL CONNECTIONS & PARKING RETURN BRANCH
4. PROVIDE ENERGY EFFICIENT WATER SUPPLY TO WATER HEATERS (HEAT TRAP TRAP) IN ALL CONNECTIONS & PARKING RETURN BRANCH
5. PROVIDE ENERGY EFFICIENT WATER SUPPLY TO WATER HEATERS (HEAT TRAP TRAP) IN ALL CONNECTIONS & PARKING RETURN BRANCH
6. PROVIDE ENERGY EFFICIENT WATER SUPPLY TO WATER HEATERS (HEAT TRAP TRAP) IN ALL CONNECTIONS & PARKING RETURN BRANCH

GENERAL DEMOLITION NOTES:

1. REFER TO GENERAL DEMOLITION CONDITIONS AND EXISTING NOTES ON SHEET P001.
2. DEMOLITION SHALL BE ACCORDING TO THE CITY OF PALM DESERT DEMOLITION ORDINANCE.
3. DEMOLITION SHALL BE ACCORDING TO THE CITY OF PALM DESERT DEMOLITION ORDINANCE.
4. DEMOLITION SHALL BE ACCORDING TO THE CITY OF PALM DESERT DEMOLITION ORDINANCE.
5. DEMOLITION SHALL BE ACCORDING TO THE CITY OF PALM DESERT DEMOLITION ORDINANCE.
6. DEMOLITION SHALL BE ACCORDING TO THE CITY OF PALM DESERT DEMOLITION ORDINANCE.

EXISTING PLUMBING CONDITIONS:

1. COMPONENTS OF PLUMBING, MECHANICAL AND ELECTRICAL EQUIPMENT, PIPING, DUCTWORK AND CONDUIT SHALL BE DEMOLISHED AND REMOVED FROM THE PROJECT SITE.
2. DEMOLITION SHALL BE ACCORDING TO THE CITY OF PALM DESERT DEMOLITION ORDINANCE.
3. DEMOLITION SHALL BE ACCORDING TO THE CITY OF PALM DESERT DEMOLITION ORDINANCE.
4. DEMOLITION SHALL BE ACCORDING TO THE CITY OF PALM DESERT DEMOLITION ORDINANCE.
5. DEMOLITION SHALL BE ACCORDING TO THE CITY OF PALM DESERT DEMOLITION ORDINANCE.
6. DEMOLITION SHALL BE ACCORDING TO THE CITY OF PALM DESERT DEMOLITION ORDINANCE.

PLUMBING FITTINGS:

- 4" FLOW
- 6" FLOW
- 8" FLOW
- 10" FLOW
- 12" FLOW
- 14" FLOW
- 16" FLOW
- 18" FLOW
- 20" FLOW
- 24" FLOW
- 30" FLOW
- 36" FLOW
- 42" FLOW
- 48" FLOW
- 54" FLOW
- 60" FLOW
- 72" FLOW
- 84" FLOW
- 96" FLOW
- 108" FLOW
- 120" FLOW
- 144" FLOW
- 168" FLOW
- 192" FLOW
- 216" FLOW
- 240" FLOW
- 288" FLOW
- 336" FLOW
- 384" FLOW
- 432" FLOW
- 480" FLOW
- 528" FLOW
- 576" FLOW
- 624" FLOW
- 672" FLOW
- 720" FLOW
- 768" FLOW
- 816" FLOW
- 864" FLOW
- 912" FLOW
- 960" FLOW
- 1008" FLOW
- 1056" FLOW
- 1104" FLOW
- 1152" FLOW
- 1200" FLOW
- 1248" FLOW
- 1296" FLOW
- 1344" FLOW
- 1392" FLOW
- 1440" FLOW
- 1488" FLOW
- 1536" FLOW
- 1584" FLOW
- 1632" FLOW
- 1680" FLOW
- 1728" FLOW
- 1776" FLOW
- 1824" FLOW
- 1872" FLOW
- 1920" FLOW
- 1968" FLOW
- 2016" FLOW
- 2064" FLOW
- 2112" FLOW
- 2160" FLOW
- 2208" FLOW
- 2256" FLOW
- 2304" FLOW
- 2352" FLOW
- 2400" FLOW
- 2448" FLOW
- 2496" FLOW
- 2544" FLOW
- 2592" FLOW
- 2640" FLOW
- 2688" FLOW
- 2736" FLOW
- 2784" FLOW
- 2832" FLOW
- 2880" FLOW
- 2928" FLOW
- 2976" FLOW
- 3024" FLOW
- 3072" FLOW
- 3120" FLOW
- 3168" FLOW
- 3216" FLOW
- 3264" FLOW
- 3312" FLOW
- 3360" FLOW
- 3408" FLOW
- 3456" FLOW
- 3504" FLOW
- 3552" FLOW
- 3600" FLOW
- 3648" FLOW
- 3696" FLOW
- 3744" FLOW
- 3792" FLOW
- 3840" FLOW
- 3888" FLOW
- 3936" FLOW
- 3984" FLOW
- 4032" FLOW
- 4080" FLOW
- 4128" FLOW
- 4176" FLOW
- 4224" FLOW
- 4272" FLOW
- 4320" FLOW
- 4368" FLOW
- 4416" FLOW
- 4464" FLOW
- 4512" FLOW
- 4560" FLOW
- 4608" FLOW
- 4656" FLOW
- 4704" FLOW
- 4752" FLOW
- 4800" FLOW
- 4848" FLOW
- 4896" FLOW
- 4944" FLOW
- 4992" FLOW
- 5040" FLOW
- 5088" FLOW
- 5136" FLOW
- 5184" FLOW
- 5232" FLOW
- 5280" FLOW
- 5328" FLOW
- 5376" FLOW
- 5424" FLOW
- 5472" FLOW
- 5520" FLOW
- 5568" FLOW
- 5616" FLOW
- 5664" FLOW
- 5712" FLOW
- 5760" FLOW
- 5808" FLOW
- 5856" FLOW
- 5904" FLOW
- 5952" FLOW
- 6000" FLOW
- 6048" FLOW
- 6096" FLOW
- 6144" FLOW
- 6192" FLOW
- 6240" FLOW
- 6288" FLOW
- 6336" FLOW
- 6384" FLOW
- 6432" FLOW
- 6480" FLOW
- 6528" FLOW
- 6576" FLOW
- 6624" FLOW
- 6672" FLOW
- 6720" FLOW
- 6768" FLOW
- 6816" FLOW
- 6864" FLOW
- 6912" FLOW
- 6960" FLOW
- 7008" FLOW
- 7056" FLOW
- 7104" FLOW
- 7152" FLOW
- 7200" FLOW
- 7248" FLOW
- 7296" FLOW
- 7344" FLOW
- 7392" FLOW
- 7440" FLOW
- 7488" FLOW
- 7536" FLOW
- 7584" FLOW
- 7632" FLOW
- 7680" FLOW
- 7728" FLOW
- 7776" FLOW
- 7824" FLOW
- 7872" FLOW
- 7920" FLOW
- 7968" FLOW
- 8016" FLOW
- 8064" FLOW
- 8112" FLOW
- 8160" FLOW
- 8208" FLOW
- 8256" FLOW
- 8304" FLOW
- 8352" FLOW
- 8400" FLOW
- 8448" FLOW
- 8496" FLOW
- 8544" FLOW
- 8592" FLOW
- 8640" FLOW
- 8688" FLOW
- 8736" FLOW
- 8784" FLOW
- 8832" FLOW
- 8880" FLOW
- 8928" FLOW
- 8976" FLOW
- 9024" FLOW
- 9072" FLOW
- 9120" FLOW
- 9168" FLOW
- 9216" FLOW
- 9264" FLOW
- 9312" FLOW
- 9360" FLOW
- 9408" FLOW
- 9456" FLOW
- 9504" FLOW
- 9552" FLOW
- 9600" FLOW
- 9648" FLOW
- 9696" FLOW
- 9744" FLOW
- 9792" FLOW
- 9840" FLOW
- 9888" FLOW
- 9936" FLOW
- 9984" FLOW
- 10032" FLOW
- 10080" FLOW
- 10128" FLOW
- 10176" FLOW
- 10224" FLOW
- 10272" FLOW
- 10320" FLOW
- 10368" FLOW
- 10416" FLOW
- 10464" FLOW
- 10512" FLOW
- 10560" FLOW
- 10608" FLOW
- 10656" FLOW
- 10704" FLOW
- 10752" FLOW
- 10800" FLOW
- 10848" FLOW
- 10896" FLOW
- 10944" FLOW
- 10992" FLOW
- 11040" FLOW
- 11088" FLOW
- 11136" FLOW
- 11184" FLOW
- 11232" FLOW
- 11280" FLOW
- 11328" FLOW
- 11376" FLOW
- 11424" FLOW
- 11472" FLOW
- 11520" FLOW
- 11568" FLOW
- 11616" FLOW
- 11664" FLOW
- 11712" FLOW
- 11760" FLOW
- 11808" FLOW
- 11856" FLOW
- 11904" FLOW
- 11952" FLOW
- 12000" FLOW
- 12048" FLOW
- 12096" FLOW
- 12144" FLOW
- 12192" FLOW
- 12240" FLOW
- 12288" FLOW
- 12336" FLOW
- 12384" FLOW
- 12432" FLOW
- 12480" FLOW
- 12528" FLOW
- 12576" FLOW
- 12624" FLOW
- 12672" FLOW
- 12720" FLOW
- 12768" FLOW
- 12816" FLOW
- 12864" FLOW
- 12912" FLOW
- 12960" FLOW
- 13008" FLOW
- 13056" FLOW
- 13104" FLOW
- 13152" FLOW
- 13200" FLOW
- 13248" FLOW
- 13296" FLOW
- 13344" FLOW
- 13392" FLOW
- 13440" FLOW
- 13488" FLOW
- 13536" FLOW
- 13584" FLOW
- 13632" FLOW
- 13680" FLOW
- 13728" FLOW
- 13776" FLOW
- 13824" FLOW
- 13872" FLOW
- 13920" FLOW
- 13968" FLOW
- 14016" FLOW
- 14064" FLOW
- 14112" FLOW
- 14160" FLOW
- 14208" FLOW
- 14256" FLOW
- 14304" FLOW
- 14352" FLOW
- 14400" FLOW
- 14448" FLOW
- 14496" FLOW
- 14544" FLOW
- 14592" FLOW
- 14640" FLOW
- 14688" FLOW
- 14736" FLOW
- 14784" FLOW
- 14832" FLOW
- 14880" FLOW
- 14928" FLOW
- 14976" FLOW
- 15024" FLOW
- 15072" FLOW
- 15120" FLOW
- 15168" FLOW
- 15216" FLOW
- 15264" FLOW
- 15312" FLOW
- 15360" FLOW
- 15408" FLOW
- 15456" FLOW
- 15504" FLOW
- 15552" FLOW
- 15600" FLOW
- 15648" FLOW
- 15696" FLOW
- 15744" FLOW
- 15792" FLOW
- 15840" FLOW
- 15888" FLOW
- 15936" FLOW
- 15984" FLOW
- 16032" FLOW
- 16080" FLOW
- 16128" FLOW
- 16176" FLOW
- 16224" FLOW
- 16272" FLOW
- 16320" FLOW
- 16368" FLOW
- 16416" FLOW
- 16464" FLOW
- 16512" FLOW
- 16560" FLOW
- 16608" FLOW
- 16656" FLOW
- 16704" FLOW
- 16752" FLOW
- 16800" FLOW
- 16848" FLOW
- 16896" FLOW
- 16944" FLOW
- 16992" FLOW
- 17040" FLOW
- 17088" FLOW
- 17136" FLOW
- 17184" FLOW
- 17232" FLOW
- 17280" FLOW
- 17328" FLOW
- 17376" FLOW
- 17424" FLOW
- 17472" FLOW
- 17520" FLOW
- 17568" FLOW
- 17616" FLOW
- 17664" FLOW
- 17712" FLOW
- 17760" FLOW
- 17808" FLOW
- 17856" FLOW
- 17904" FLOW
- 17952" FLOW
- 18000" FLOW
- 18048" FLOW
- 18096" FLOW
- 18144" FLOW
- 18192" FLOW
- 18240" FLOW
- 18288" FLOW
- 18336" FLOW
- 18384" FLOW
- 18432" FLOW
- 18480" FLOW
- 18528" FLOW
- 18576" FLOW
- 18624" FLOW
- 18672" FLOW
- 18720" FLOW
- 18768" FLOW
- 18816" FLOW
- 18864" FLOW
- 18912" FLOW
- 18960" FLOW
- 19008" FLOW
- 19056" FLOW
- 19104" FLOW
- 19152" FLOW
- 19200" FLOW
- 19248" FLOW
- 19296" FLOW
- 19344" FLOW
- 19392" FLOW
- 19440" FLOW
- 19488" FLOW
- 19536" FLOW
- 19584" FLOW
- 19632" FLOW
- 19680" FLOW
- 19728" FLOW
- 19776" FLOW
- 19824" FLOW
- 19872" FLOW
- 19920" FLOW
- 19968" FLOW
- 20016" FLOW
- 20064" FLOW
- 20112" FLOW
- 20160" FLOW
- 20208" FLOW
- 20256" FLOW
- 20304" FLOW
- 20352" FLOW
- 20400" FLOW
- 20448" FLOW
- 20496" FLOW
- 20544" FLOW
- 20592" FLOW
- 20640" FLOW
- 20688" FLOW
- 20736" FLOW
- 20784" FLOW
- 20832" FLOW
- 20880" FLOW
- 20928" FLOW
- 20976" FLOW
- 21024" FLOW
- 21072" FLOW
- 21120" FLOW
- 21168" FLOW
- 21216" FLOW
- 21264" FLOW
- 21312" FLOW
- 21360" FLOW
- 21408" FLOW
- 21456" FLOW
- 21504" FLOW
- 21552" FLOW
- 21600" FLOW
- 21648" FLOW
- 21696" FLOW
- 21744" FLOW
- 21792" FLOW
- 21840" FLOW
- 21888" FLOW
- 21936" FLOW
- 21984" FLOW
- 22032" FLOW
- 22080" FLOW
- 22128" FLOW
- 22176" FLOW
- 22224" FLOW
- 22272" FLOW
- 22320" FLOW
- 22368" FLOW
- 22416" FLOW
- 22464" FLOW
- 22512" FLOW
- 22560" FLOW
- 22608" FLOW
- 22656" FLOW
- 22704" FLOW
- 22752" FLOW
- 22800" FLOW
- 22848" FLOW
- 22896" FLOW
- 22944" FLOW
- 22992" FLOW
- 23040" FLOW
- 23088" FLOW
- 23136" FLOW
- 23184" FLOW
- 23232" FLOW
- 23280" FLOW
- 23328" FLOW
- 23376" FLOW
- 23424" FLOW
- 23472" FLOW
- 23520" FLOW
- 23568" FLOW
- 23616" FLOW
- 23664" FLOW
- 23712" FLOW
- 23760" FLOW
- 23808" FLOW
- 23856" FLOW
- 23904" FLOW
- 23952" FLOW
- 24000" FLOW
- 24048" FLOW
- 24096" FLOW
- 24144" FLOW
- 24192" FLOW
- 24240" FLOW
- 24288" FLOW
- 24336" FLOW
- 24384" FLOW
- 24432" FLOW
- 24480" FLOW
- 24528" FLOW
- 24576" FLOW
- 24624" FLOW
- 24672" FLOW
- 24720" FLOW
- 24768" FLOW
- 24816" FLOW
- 24864" FLOW
- 24912" FLOW
- 24960" FLOW
- 25008" FLOW
- 25056" FLOW
- 25104" FLOW
- 25152" FLOW
- 25200" FLOW
- 25248" FLOW
- 25296" FLOW
- 25344" FLOW
- 25392" FLOW
- 25440" FLOW
- 25488" FLOW
- 25536" FLOW
- 25584" FLOW
- 25632" FLOW
- 25680" FLOW
- 25728" FLOW
- 25776" FLOW
- 25824" FLOW
- 25872" FLOW
- 25920" FLOW
- 25968" FLOW
- 26016" FLOW
- 26064" FLOW
- 26112" FLOW
- 26160" FLOW
- 26208" FLOW
- 26256" FLOW
- 26304" FLOW
- 26352" FLOW
- 26400" FLOW
- 26448" FLOW
- 26496" FLOW
- 26544" FLOW
- 26592" FLOW
- 26640" FLOW
- 26688" FLOW
- 26736" FLOW
- 26784" FLOW
- 26832" FLOW
- 26880" FLOW
- 26928" FLOW
- 26976" FLOW
- 27024" FLOW
- 27072" FLOW
- 27120" FLOW
- 27168" FLOW
- 27216" FLOW
- 27264" FLOW
- 27312" FLOW
- 27360" FLOW
- 27408" FLOW
- 27456" FLOW
- 27504" FLOW
- 27552" FLOW
- 27600" FLOW
- 27648" FLOW
- 27696" FLOW
- 27744" FLOW
- 27792" FLOW
- 27840" FLOW
- 27888" FLOW
- 27936" FLOW
- 27984" FLOW
- 28032" FLOW
- 28080" FLOW
- 28128" FLOW
- 28176" FLOW
- 28224" FLOW
- 28272" FLOW
- 28320" FLOW
- 28368" FLOW
- 28416" FLOW
- 28464" FLOW
- 28512" FLOW
- 28560" FLOW
- 28608" FLOW
- 28656" FLOW
- 28704" FLOW
- 28752" FLOW
- 28800" FLOW
- 28848" FLOW
- 28896" FLOW
- 28944" FLOW
- 28992" FLOW
- 29040" FLOW
- 29088" FLOW
- 29136" FLOW
- 29184" FLOW
- 29232" FLOW
- 29280" FLOW
- 29328" FLOW
- 29376" FLOW
- 29424" FLOW
- 29472" FLOW
- 29520" FLOW
- 29568" FLOW
- 29616" FLOW
- 29664" FLOW
- 29712" FLOW
- 29760" FLOW
- 29808" FLOW
- 29856" FLOW
- 29904" FLOW
- 29952" FLOW
- 30000" FLOW

PLUMBING ABBREVIATIONS:

- AD ABOVE GRADE
- AG ABOVE GRADE
- AP ABOVE GRADE
- AS ABOVE GRADE
- AT ABOVE GRADE
- AV ABOVE GRADE
- AW ABOVE GRADE
- AX ABOVE GRADE
- AY ABOVE GRADE
- AZ ABOVE GRADE
- BA ABOVE GRADE
- BB ABOVE GRADE
- BC ABOVE GRADE
- BD ABOVE GRADE
- BE ABOVE GRADE
- BF ABOVE GRADE
- BG ABOVE GRADE
- BH ABOVE GRADE
- BI ABOVE GRADE
- BJ ABOVE GRADE
- BK ABOVE GRADE
- BL ABOVE GRADE
- BM ABOVE GRADE
- BN ABOVE GRADE
- BO ABOVE GRADE
- BP ABOVE GRADE
- BQ ABOVE GRADE
- BR ABOVE GRADE
- BS ABOVE GRADE
- BT ABOVE GRADE
- BU ABOVE GRADE
- BV ABOVE GRADE
- BW ABOVE GRADE
- BX ABOVE GRADE
- BY ABOVE GRADE
- BZ ABOVE GRADE
- CA ABOVE GRADE
- CB ABOVE GRADE
- CC ABOVE GRADE
- CD ABOVE GRADE
- CE ABOVE GRADE
- CF ABOVE GRADE
- CG ABOVE GRADE
- CH ABOVE GRADE
- CI ABOVE GRADE
- CJ ABOVE GRADE
- CK ABOVE GRADE
- CL ABOVE GRADE
- CM ABOVE GRADE
- CN ABOVE GRADE
- CO ABOVE GRADE
- CP ABOVE GRADE
- CQ ABOVE GRADE
- CR ABOVE GRADE
- CS ABOVE GRADE
- CT ABOVE GRADE
- CU ABOVE GRADE
- CV ABOVE GRADE
- CW ABOVE GRADE
- CX ABOVE GRADE
- CY ABOVE GRADE
- CZ ABOVE GRADE
- DA ABOVE GRADE
- DB ABOVE GRADE
- DC ABOVE GRADE
- DD ABOVE GRADE
- DE ABOVE GRADE
- DF ABOVE GRADE
- DG ABOVE GRADE
- DH ABOVE GRADE
- DI ABOVE GRADE
- DJ ABOVE GRADE
- DK ABOVE GRADE
- DL ABOVE GRADE
- DM ABOVE GRADE
- DN ABOVE GRADE
- DO ABOVE GRADE
- DP ABOVE GRADE
- DQ ABOVE GRADE
- DR ABOVE GRADE
- DS ABOVE GRADE
- DT ABOVE GRADE
- DU ABOVE GRADE
- DV ABOVE GRADE
- DW ABOVE GRADE
- DX ABOVE GRADE
- DY ABOVE GRADE
- DZ ABOVE GRADE
- EA ABOVE GRADE
- EB ABOVE GRADE
- EC ABOVE GRADE
- ED ABOVE GRADE
- EE ABOVE GRADE
- EF ABOVE GRADE
- EG ABOVE GRADE
- EH ABOVE GRADE
- EI ABOVE GRADE
- EJ ABOVE GRADE
- EK ABOVE GRADE
- EL ABOVE GRADE
- EM ABOVE GRADE
- EN ABOVE GRADE
- EO ABOVE GRADE
- EP ABOVE GRADE
- EQ ABOVE GRADE
- ER ABOVE GRADE
- ES ABOVE GRADE
- ET ABOVE GRADE
- EU ABOVE GRADE
- EV ABOVE GRADE
- EW ABOVE GRADE
- EX ABOVE GRADE
- EY ABOVE GRADE
- EZ ABOVE GRADE
- FA ABOVE GRADE
- FB ABOVE GRADE
- FC ABOVE GRADE
- FD ABOVE GRADE
- FE ABOVE GRADE
- FF ABOVE GRADE
- FG ABOVE GRADE
- FH ABOVE GRADE
- FI ABOVE GRADE
- FJ ABOVE GRADE
- FK ABOVE GRADE
- FL ABOVE GRADE
- FM ABOVE GRADE
- FN ABOVE GRADE
- FO ABOVE GRADE
- FP ABOVE GRADE
- FQ ABOVE GRADE
- FR ABOVE GRADE
- FS ABOVE GRADE
- FT ABOVE GRADE
- FU ABOVE GRADE
- FV ABOVE GRADE
- FW ABOVE GRADE
- FX ABOVE GRADE
- FY ABOVE GRADE
- FZ ABOVE GRADE
- GA ABOVE GRADE
- GB ABOVE GRADE
- GC ABOVE GRADE
- GD ABOVE GRADE
- GE ABOVE GRADE
- GF ABOVE GRADE
- GG ABOVE GRADE
- GH ABOVE GRADE
- GI ABOVE GRADE
- GJ ABOVE GRADE
- GK ABOVE GRADE
- GL ABOVE GRADE
- GM ABOVE GRADE
- GN ABOVE GRADE
- GO ABOVE GRADE
- GP ABOVE GRADE
- GQ ABOVE GRADE
- GR ABOVE GRADE
- GS ABOVE GRADE
- GT ABOVE GRADE
- GU ABOVE GRADE
- GV ABOVE GRADE
- GW ABOVE GRADE
- GX ABOVE GRADE
- GY ABOVE GRADE
- GZ ABOVE GRADE
- HA ABOVE GRADE
- HB ABOVE GRADE
- HC ABOVE GRADE
- HD ABOVE GRADE
- HE ABOVE GRADE
- HF ABOVE GRADE
- HG ABOVE GRADE
- HH ABOVE GRADE
- HI ABOVE GRADE
- HJ ABOVE GRADE
- HK ABOVE GRADE
- HL ABOVE GRADE
- HM ABOVE GRADE
- HN ABOVE GRADE
- HO ABOVE GRADE
- HP ABOVE GRADE
- HQ ABOVE GRADE
- HR ABOVE GRADE
- HS ABOVE GRADE
- HT ABOVE GRADE
- HU ABOVE GRADE
- HV ABOVE GRADE
- HW ABOVE GRADE
- HX ABOVE GRADE
- HY ABOVE GRADE
- HZ ABOVE GRADE
- IA ABOVE GRADE
- IB ABOVE GRADE
- IC ABOVE GRADE
- ID ABOVE GRADE
- IE ABOVE GRADE
- IF ABOVE GRADE
- IG ABOVE GRADE
- IH ABOVE GRADE
- II ABOVE GRADE
- IJ ABOVE GRADE
- IK ABOVE GRADE
- IL ABOVE GRADE
- IM ABOVE GRADE
- IN ABOVE GRADE
- IO ABOVE GRADE
- IP ABOVE GRADE
- IQ ABOVE GRADE
- IR ABOVE GRADE
- IS

GENERAL NOTES:

1. REFER TO SHEET E01 FOR ELECTRICAL SPECIFICATIONS.
2. REFER TO BERT PANEL SCHEDULES FOR PANEL LOCATIONS AND NEW BRANCH CONNECTION.
3. ALL DEVICES ARE NEW UNLESS NOTED OTHERWISE.
4. ELECTRICAL CONTRACTOR SHALL REFER TO SPECIFIC EQUIPMENT SCHEDULES FOR ALL ELECTRICAL EQUIPMENT. ALL ELECTRICAL CONNECTIONS SHALL BE MADE IN ACCORDANCE WITH THE NATIONAL ELECTRICAL CODE (NEC) AND ALL APPLICABLE LOCAL CODES. ALL WORK SHALL BE IN ACCORDANCE WITH THE CITY OF PALM DESERT ELECTRICAL DEPARTMENT PERMITS AND ALL APPLICABLE LOCAL CODES. ALL WORK SHALL BE IN ACCORDANCE WITH THE CITY OF PALM DESERT ELECTRICAL DEPARTMENT PERMITS AND ALL APPLICABLE LOCAL CODES.

KEYNOTES:

1. REMOVE ALL EXISTING LIGHT FIXTURES, CONTROLS, AND BRANCH CONNECTIONS.
2. PROVIDE ASTROMICAL TRIM FOR OUTDOOR LIGHTING.
3. PROVIDE OCCUPANCY SENSORS TO LIGHT AND OUTSIDE FAN CONNECTIONS.
4. JUNCTION BOX AND PANEL CONNECTION TO HANGUP PER PROVIDE.
5. JUNCTION BOX AND PANEL CONNECTION TO 20 U. WATER HEATER. PROVIDE LOCKOFF DEVICE ON BRANCH CIRCUIT BREAKER.

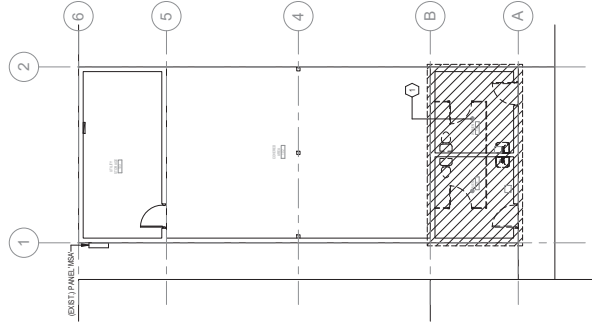

① ELECTRICAL DEMOLITION PLAN
1/8" = 1'-0"

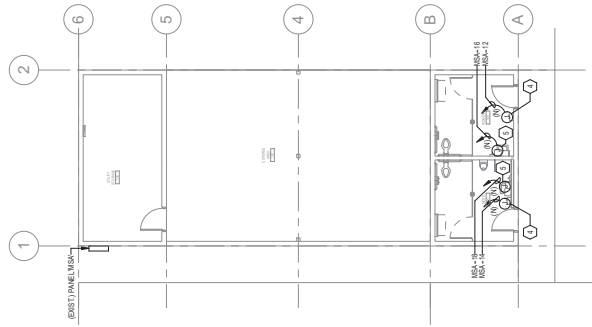

② ELECTRICAL POWER PLAN
1/8" = 1'-0"

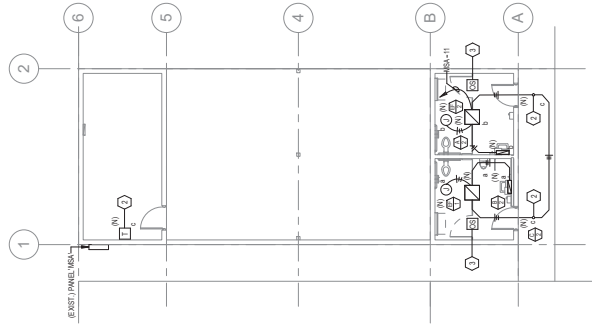

③ ELECTRICAL LIGHTING PLAN
1/8" = 1'-0"

SHEET TITLE: ELECTRICAL PLANS
DATE: 01.28.26
SHEET NUMBER: 25-008
PROJECT NUMBER: 25-008

INSTRUMENTS OF SERVICE
McAuliffe & Co. ARCHITECTS
44-889 Town Center Way, Suite D513 Palm Desert, CA 92260
T: 760.773.0907 www.mcauliffe.com



REVISIONS	PERMIT
01/23/2026	



rtm
engineering consultants
1000 W. 10th St., Suite 100, Palm Desert, CA 92260
P: 760.773.0907

RESTROOM IMPROVEMENTS
Salton Community Services District
SALTON CITY PARK
2208-2210 IRIDENCENT AVE
THERMAL, CA 92274



M. LIGHTING ALLOWANCE PER SPECIFIC AREA	This section does not apply to this project.
N. EXISTING CONDITIONS POWER ALLOWANCE (Iterations only)	This section does not apply to this project.
O. DECLARATION OF REQUIRED CERTIFICATES OF INSTALLATION	<p>Additional items: These documents must be provided to the building inspector during construction and can be found online.</p> <p>Form/Title: _____</p>
P. DECLARATION OF REQUIRED CERTIFICATES OF ACCEPTANCE	<p>Additional items: These documents must be provided to the building inspector during construction and can be found online.</p> <p>Form/Title: _____</p>

CA Building Energy Efficiency Standards - 2025 Residential Compliance
 Documentation Software: Energy Code 4e
 Report Generated: 2024-05-27 16:18:25

DOCUMENTATION AUTHOR'S DECLARATION STATEMENT	I certify that this Certificate of Compliance documentation is accurate and complete.
RESPONSIBLE PERSON'S DECLARATION STATEMENT	<p>I, the undersigned, certify that I am a duly licensed professional engineer in the State of California.</p> <p>I am the design professional responsible for the building design or system design identified on this Certificate of Compliance (responsible design).</p> <p>I have read and understand the requirements, conditions, and restrictions of this Certificate of Compliance and I agree to comply with the requirements, conditions, and restrictions of this Certificate of Compliance.</p> <p>I have read and understand the requirements, conditions, and restrictions of this Certificate of Compliance and I agree to comply with the requirements, conditions, and restrictions of this Certificate of Compliance.</p> <p>I have read and understand the requirements, conditions, and restrictions of this Certificate of Compliance and I agree to comply with the requirements, conditions, and restrictions of this Certificate of Compliance.</p>

CA Building Energy Efficiency Standards - 2025 Residential Compliance
 Documentation Software: Energy Code 4e
 Report Generated: 2024-05-27 16:18:25



RESTROOM IMPROVEMENTS
Salton Community Services District
SALTON CITY PARK
 2208-2210 IRINDENCENT AVE
 THERMAL, CA 92274



rtm
 engineering consultants
 1100 THE WAY TO THE WEST, SUITE 100
 THERMAL, CA 92274



McAuliffe & Co.
ARCHITECTS

44-89 Town Center Way, Suite D513 Palm Desert, CA 92260 T: 760.773.0907 www.warchma.com

INSTRUMENTS OF SERVICE
 I, the undersigned, certify that I am a duly licensed professional engineer in the State of California. I have read and understand the requirements, conditions, and restrictions of this Certificate of Compliance and I agree to comply with the requirements, conditions, and restrictions of this Certificate of Compliance.